

Mounting Instructions

ISO 5211 Dimensionally Compliant Bracket, Coupling, and Actuator

For the following Swagelok® Ball Valves

- 40G series
- 40 series
- 83 series
- Alternative Fuel Service (AFS)
- SK series

This document shows how to install an ISO 5211 dimensionally compliant mounting bracket to the following Swagelok ball valves:

- 40G series (2- and 3-way only)
- 40 series (2- and 3-way only, with double-flat style stem)
- 83 series (all)
- AFS valves (all)
- SK series (all)

The valve shown is a 40 series ball valve.

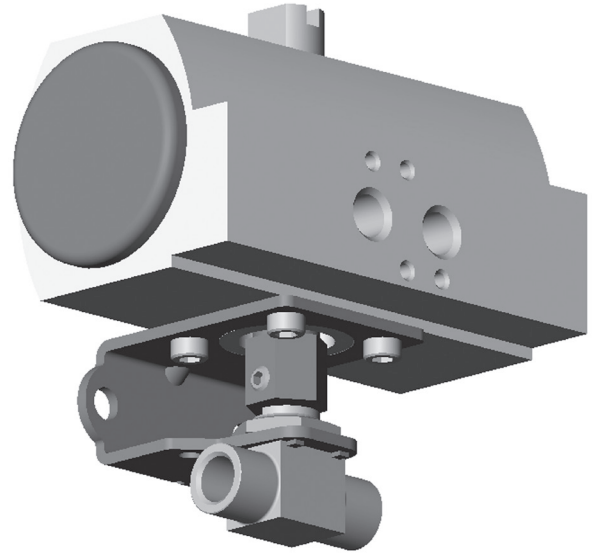

⚠ WARNING

Before removing any installed valve you must:

- depressurize the system
- cycle the valve
- purge the valve

⚠ CAUTION

You must verify the desired flow patterns after these assembly steps are completed.

⚠ CAUTION

Actuated assemblies must be properly aligned and supported. Improper alignment or inadequate support of the actuated assembly may result in leakage or premature valve failure.

Bracket Kit Contents

Mounting Bracket

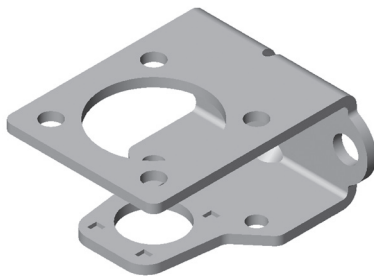

Coupling

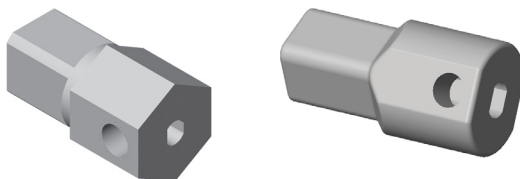

- 40 series
- 83 series
- AFS

- 40G series
- SK series

Coupling Set Screw



- 40 series
- 40G series
- AFS
- SK series

83 series

Socket Head Cap Screws (4)



Swagelok®

Tool Requirements



Valve Series	Panel Nut	Coupling Set Screw	Handle Set Screw
	Open-End Extension	Hex Wrench	Hex Wrench
41G, 42G, 41, 42	3/4 in.	3 mm	5/64 in.
43G	1 in.	3 mm	3/32 in.
SK	1 in.	3 mm	3/32 in.
43	1 in.	4 mm	3/32 in.
44	1 1/4 in.	4 mm	1/8 in.
45	1 3/4 in.	5 mm	5/32 in.
83	1 1/8 in.	3/32 in.	3/32 in.
AFS	1 3/4 in.	5 mm	5/32 in.



ISO 5211 Flange Size	Socket Head Cap Screw Size	
	Metric	Fractional
F03, F04	4 mm	5/32 in.
F05	5 mm	3/16 in.
F07	6 mm	5/16 in.



Torque wrench capable of applying up to 400 in.-lb (45.2 N·m, 461 cm·kg)

Actuator Preparation

1. Insert the **coupling** into the **actuator drive socket**.

40G Series 40 Series SK Series	Align the coupling flats to match valve stem flats so the coupling set screw will contact the larger stem flat. (See Valve Preparation .)
83 Series	Align coupling set screw with the valve stem hole. (See Valve Preparation .)
AFS	Align the coupling flats to match valve stem flats. (See Valve Preparation .)

Note: Coupling orientation shown is an example. The valve flow pattern will determine actual coupling orientation.

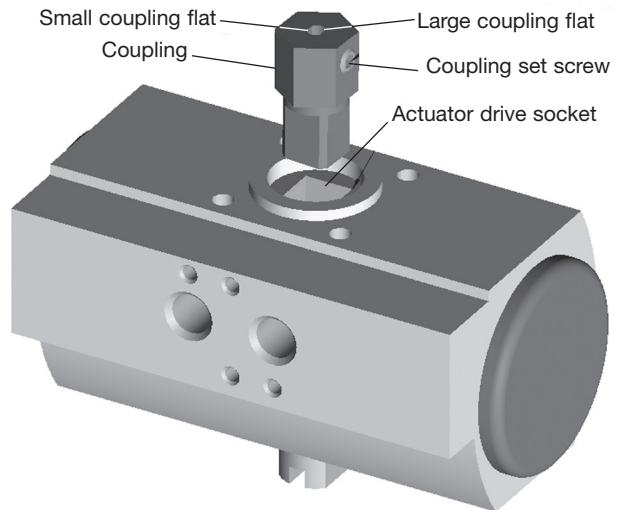

2. Place the **mounting bracket** on the **actuator** and orient in the desired position. Verify the **coupling** is in the proper position to maintain desired flow pattern.

3. Attach the **mounting bracket** to the actuator with (4) **socket head cap screws** and tighten to the applicable torque.

ISO 5211 Flange Size	Torque Required		
	in.-lb	N-m	cm-kg
F03, F04	40	4.5	46
F05	75	8.5	86
F07	125	14.1	144

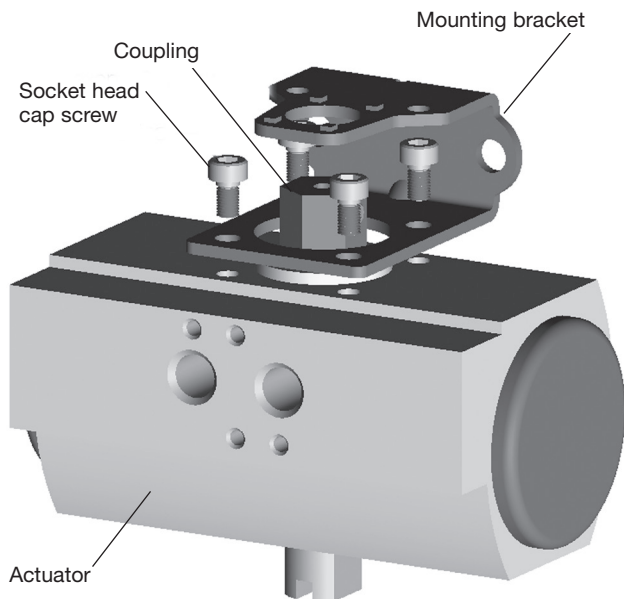

Valve Preparation

1. Put valve in the desired position. Loosen set screw and remove handle from valve.
2. Verify the orientation of the **stem flats / hole** for insertion into coupling. Visually check valve port(s).

2-way valves in *open* position

- 40G series
- 40 series
- AFS
- SK series

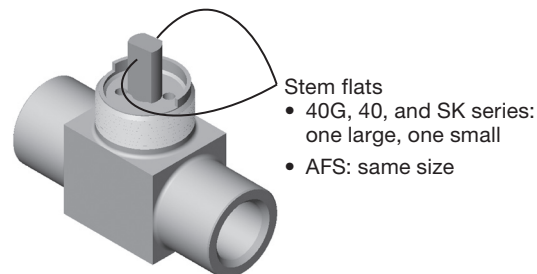

2-way valves in *closed* position

- 40G series
- 40 series
- AFS
- SK series

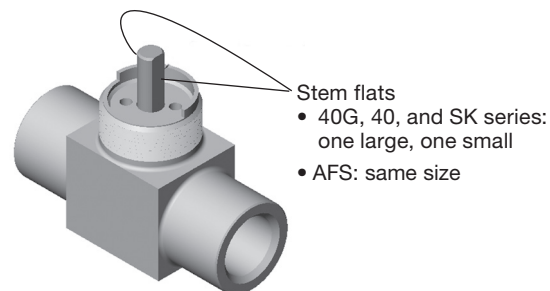

2-way 83 series valve in *open* position

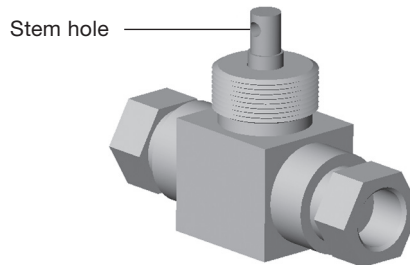

2-way 83 series valve in *closed* position

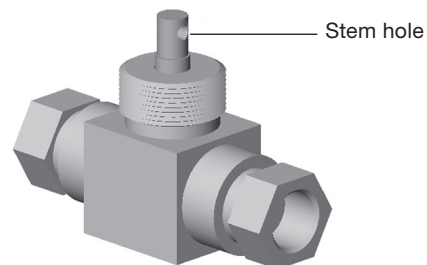

Mounting Instructions

1. Unthread the **panel nut** from the **valve**.
2. Place **panel nut** on the **coupling**.
3. Insert the **valve** through the **mounting bracket**, **panel nut**, and **coupling**. Loosen **coupling set screw** if necessary.
4. Verify desired flow pattern.
5. Thread the **panel nut** onto the **valve** and tighten to the torque shown below.

Valve Series	Torque Required		
	in.·lb	N·m	cm·kg
41G, 42G	50	5.7	58
43G	60	6.8	69
41, 42	75	6.5	86
43	150	17.0	173
SK	150	17.0	173
44	250	28.3	288
45	400	45.2	461
83	100	11.3	115
AFS	400	45.2	461

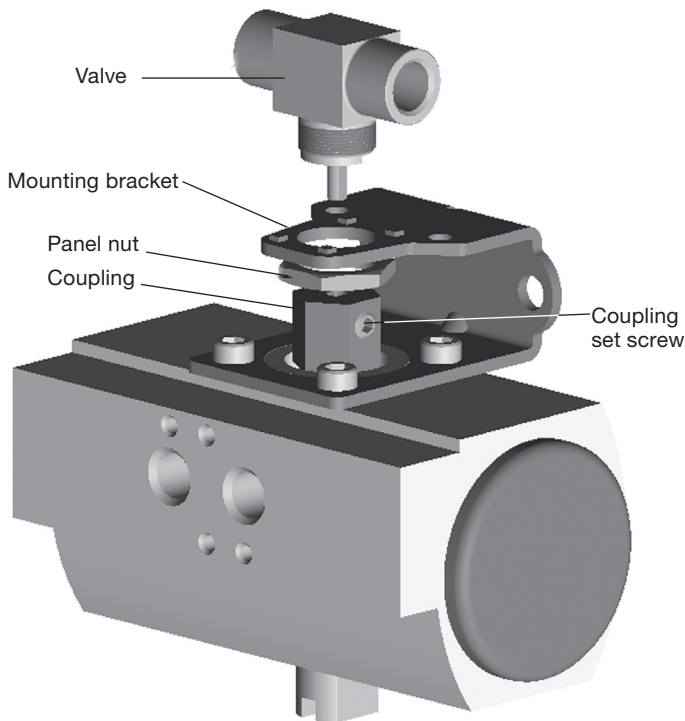

6. **40 series and SK series:** Position the **coupling** approximately 1 mm (0.04 in.) from valve body.
- 40G Series and AFS:** Slide **coupling** down to fully engage stem flat. No flat should be visible when fully engaged.
7. Tighten the **coupling set screw** to the torque shown below.

Valve Series	Torque Required		
	in.·lb	N·m	cm·kg
SK 41, 42 41G, 42G, 43G	40	4.5	46
43, 44	100	11.3	115
45	200	22.6	230
83	15	1.7	17
AFS	200	22.6	230

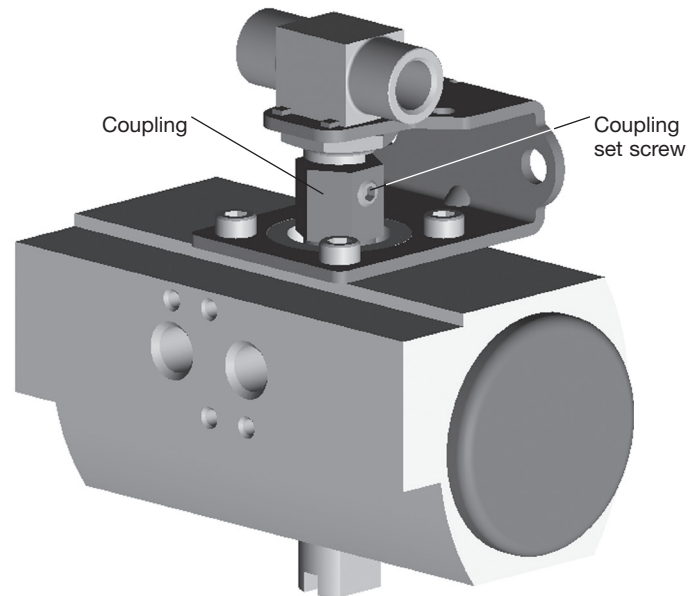

8. Test for proper valve operation by applying air pressure as specified by the actuator manufacturer.

WARNING

Do not mix/interchange Swagelok products or components not governed by industrial design standards, including Swagelok tube fitting end connections, with those of other manufacturers.