

Read the complete manual before installing and using the regulator.

Safe Product Selection

When selecting a product, the total system design must be considered to ensure safe, trouble-free performance. Function, material compatibility, adequate ratings, proper installation, operation, and maintenance are the responsibilities of the system designer and user.



WARNING

- Users must be trained and equipped for the handling, use, and servicing of pressure products and systems.
- Users must contact their gas or liquid supplier for specific safety precautions and instructions.
- Gaseous media should be free of excessive moisture to prevent icing at high flow.
- Always wear the appropriate protective clothing, including safety glasses, gloves, etc., if required.
- Follow the applicable safety and maintenance procedures.
- Obey specific local regulations.
- Do not exceed the maximum inlet and outlet pressure rating of the product or its accessories.
- Operate within the temperature limits and any other conditions specified for the product.
- Do not drop or damage the product in any other way. This may negatively affect the performance of the product which can cause the product to malfunction.
- Venting fluids and gases can be dangerous. Vent to a safe environment away from people. Ensure adequate ventilation.

Contents

Introduction	4
Overview.....	4
Standard Features.....	4
Oxygen Service	4
Installation	5
Points of Attention Before Installation	5
Installation	5
Operation	6
Required Tools for Operation.....	6
Points of Attention Before Operation.....	6
Adjusting the Set Pressure.....	6
Maintenance	7
Required Tools for Maintenance	7
Points of Attention Before Removal from the System.....	8
Removal from the System	8
Assembly Reference Data.....	9
Disassembly	12
Points of Attention Before Reassembly.....	12
Reassembly.....	12
Testing	13
Seat Leak Test	13
Shell Leak Test.....	13
Troubleshooting	14

Introduction

Overview

- The TBVS4 series are spring loaded back pressure regulators designed for low pressure, high sensitivity regulation of gases and liquids.
- For pressure and temperature rating information refer to the *Tank Blanketing Pressure Regulators, RHPS Series* catalog, MS-02-431.



WARNING

Check that system pressures and temperatures do not exceed those stated on the regulator as this could result in product failure.

Standard Features

- Bolted construction
- Stainless steel as standard
- Fully serviceable
- Diaphragm sensing
- Millibar pressure control

Oxygen Service

- For more information about hazards and risks of oxygen enriched systems see the *Swagelok Oxygen System Safety* technical report (MS-06-13).
- Cleaning and packaging to ensure compliance with product cleanliness requirements stated in ASTM G93 Level C is available. Refer to the *Tank Blanketing Pressure Regulators, RHPS Series catalog, MS-02-431*, for additional information.

Installation



CAUTION

Do not use the regulator as a shutoff device. A level of leakage across the regulator seat can occur during normal operation.

Points of Attention Before Installation

This regulator can be equipped with a variety of different options. Before installing the regulator you should fully understand the functions of the supplied options and the suitability of your particular regulator for the intended application.

- The preferred mounting position of the regulator is horizontal with the spring housing facing upwards per Fig 2. Alternative mounting positions may increase the risk of component wear.
- It may be necessary to remove the regulator from the system during maintenance or service. Ensure that this is possible.
- The regulator is suitable for gases or liquids. Ensure compatibility between the regulator's materials of construction and the system media.

Installation

- Verify that the regulator, its connections, and any accessories are undamaged.
- Verify that the regulator and any accessories are suitable for the system operating pressure and temperature and have suitable connections.
- At the time of delivery any gauge ports may be plugged with blind fittings. Remove these and connect gauges if desired.
- If inlet/outlet fittings are being used, assemble them to the regulator, per the manufacturer's instructions, prior to installing the regulator in the system.



CAUTION

Ensure all upstream tubing/pipework is clean and free from debris. Any swarf, lint, wire, etc. may damage the regulator, resulting in a seat leak.

- Verify the flow direction of the system and mount the regulator accordingly.
- Securely make the appropriate connections to the regulator in accordance with the procedures recommended by the connection manufacturer.
- Ensure that the tubing/pipework and the regulator are adequately supported and that there is no stress on the connections.
- Upstream and downstream shutoff valves should be installed in the system to facilitate servicing, maintenance, and troubleshooting of the regulator.

Operation

Required Tools for Operation

A 4 mm hex and a 13 mm open-ended wrench are required for changing the set pressure on a standard regulator.

Points of Attention Before Operation



CAUTION

The product can be hot or cold, depending on the environmental temperature and the process media temperature. Take the necessary precautions before operating or touching the product.

- Once the regulator closes, after being open to flow, the inlet pressure may fall a little under the set pressure. This is usually referred to as “**reseat pressure**”. This phenomenon does not indicate a problem with the regulator.
- An increase in the flow may result in a rise of the set pressure. A decrease in the flow may result in a fall of the set pressure. This is usually referred to as “**accumulation**”. This phenomenon does not indicate a problem with the regulator.
- An increase of the outlet pressure may result in a fall of the set pressure. A decrease of the outlet pressure may result in a rise of the set pressure. This is usually referred to as “**dependency**”. This phenomenon does not indicate a problem with the regulator.

Adjusting the Set Pressure

- The set pressure is the desired upstream pressure of the regulator.
 - To set the regulator, ensure that the supply pressure is greater than the required set pressure but does not exceed the maximum rating of the regulator.
 - The regulator must be able to flow in order to adjust the set pressure.
1. Open any downstream valve.
 2. To operate, turn the set screw clockwise to increase the set pressure. Turn the set screw counterclockwise to reduce the set pressure.
 3. Partially open the supply valve to allow the regulator to sense the inlet pressure with minimal flow.
 4. Close the supply valve and verify the set pressure by measuring the regulator inlet pressure.
 5. Make adjustments to the set pressure as required and repeat steps 3 and 4.
 6. To obtain the most accurate set pressure, final adjustment must be made while **increasing** the set pressure. If the desired set pressure is exceeded, reduce the pressure below this value then increase up to it.
 7. Once the regulator is set, the supply pressure can be adjusted to its normal working value.
 8. Open the supply valve fully to allow full flow during operation.
 9. When in operation make any final set pressure adjustments if required.

Maintenance









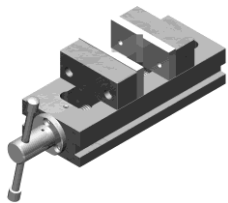

WARNING

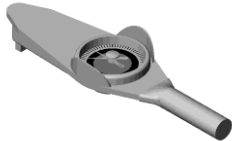
Incorrect or improper repair or servicing of this product can cause serious personal injury and property damage.

- All repairs, servicing, and testing of this product must be performed by competent personnel.
- Following any maintenance of the regulator, it is recommended that the product be tested for operation and leakage.
- The product should be checked periodically for proper and safe operation. It is the user's sole responsibility to determine the frequency of maintenance based on the application.
- To reduce maintenance related system downtime to a minimum, either during commissioning or normal operation, Swagelok recommends having maintenance kits readily available on site. The need for maintenance kits is particularly important during the commissioning phase of a system installation due to residual assembly debris remaining in the system. Such debris can cause a seat leak in the regulator, resulting in components needing to be replaced.

Required Tools for Maintenance

Smooth-jawed vise		Soft jaw needle nose pliers	
13 mm socket		Calibrated torque wrench up to 7 lbf-ft (10 N·m)	
12 mm crows foot		Lubricant (included in kit): WL-8 ^① Krytox® 240 AC ^②	
4 mm open-ended wrench		Liquid leak detector	
10 mm open-ended wrench			
5 mm hex drive			

① Standard cleaned assemblies

② ASTM G93 or SC11 cleaned assemblies

Table 1

Points of Attention Before Removal from the System

- Swagelok recommends removing the regulator from the system for servicing and maintenance.
- Follow all local system safety and maintenance procedures when removing the regulator.



WARNING

Before removing a regulator from the system, to avoid personal injury, you must:

- Depressurize the system.
- Purge the system to remove any residual system media left in the regulator.
- Always vent to a safe environment away from people and ensure there is adequate ventilation.



CAUTION

Check if the process media is hazardous or toxic. If required, take the necessary safety precautions to ensure a safe workspace and your personal safety.



CAUTION

The product can be hot or cold, depending on the environmental temperature and the process media temperature. Take the necessary precautions before operating or touching the product.

Removal from the System

1. Isolate the regulator from all pressure sources by closing all appropriate upstream valves in the system.
2. With the regulator set to the open position (i.e. set screw backed off fully counterclockwise) , open all appropriate downstream valves to allow pressure to vent from the regulator.



WARNING

Ensure all pressure on the inlet and outlet has been fully vented. The accidental release of residual trapped pressure can cause serious personal injury.

3. Disconnect and remove the regulator from the system.

Assembly Reference Data

Item	Component Name	Kit Type(s)	Torque lbf·ft (N·m)	Recommended Lubrication (included in kit per Table 1)
1	Nut	E1		
2	Lock washer	E1		
3	Body assembly	N/A		
4	Seat seal	A1, B1, B2, C1		
5	Seat	A1, B1, C1		
6	Poppet	A1, A2, B1, C1		Lubricate threads
7	Seat retainer	C1	3.7 (5)	Lubricate threads and poppet hole
8	Clamp ring	C1	3.7 (5)	Lubricate threads
9	Diaphragm	B1, B2, C1, C3		
10	Diaphragm plate	C1		
11	Lock washer	C1		
12	Diaphragm nut	C1	7 (10)	
13	Set spring	C1, C4		
14	Spring guide	C1		Lubricate central recess
15	Spring housing assembly	N/A		
16	Socket head cap screw	E1	7 (10)	Lubricate threads
17	Nut	D1		
18	Set screw	D1		Lubricate threads

Table 2

For more information on RHPS series maintenance kits, refer to the *Tank Blanketing Pressure Regulators, RHPS Series* catalog, MS-02-431.

TBVS4 Series, Exploded View

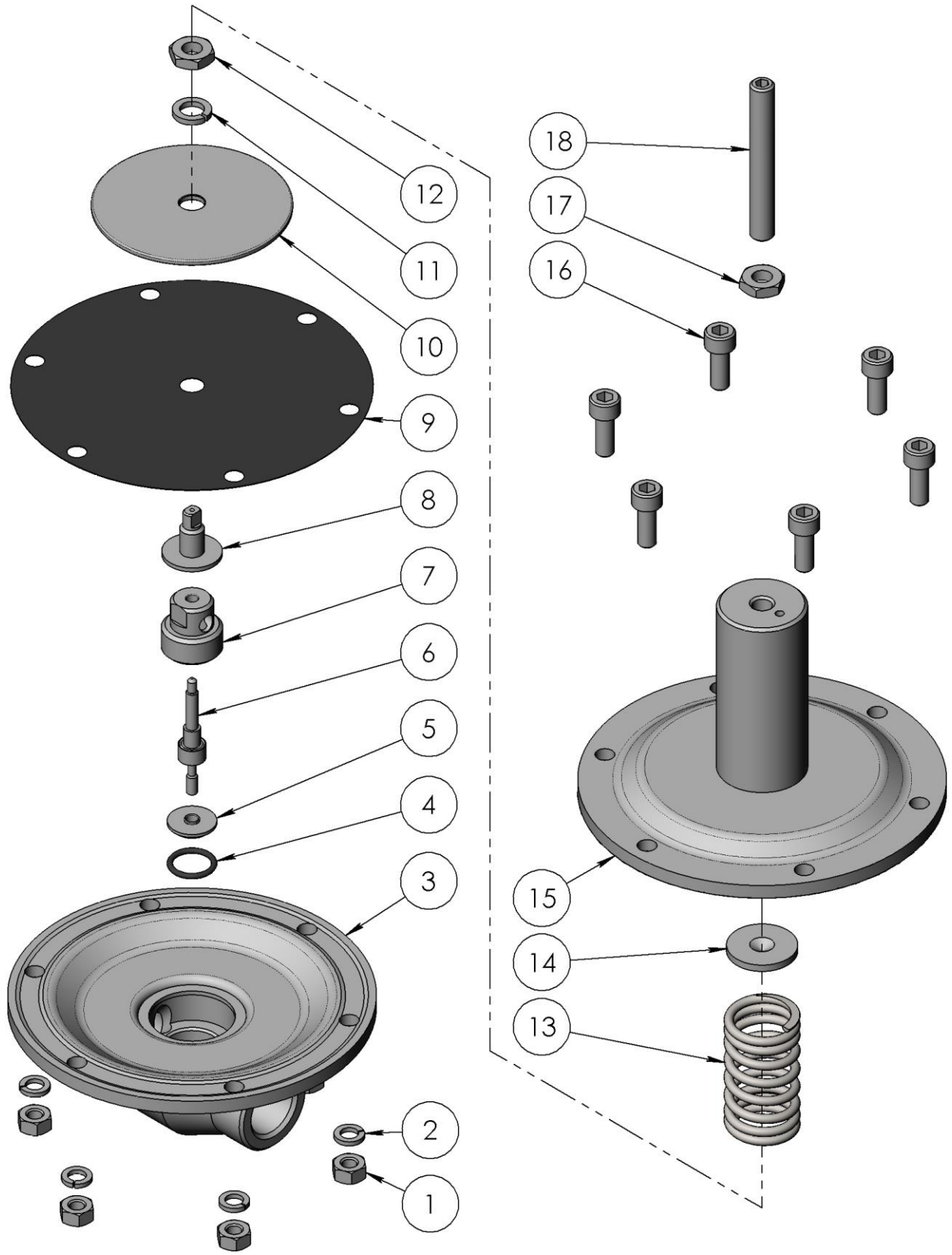

Fig 1

TBVS4 Series, Section View

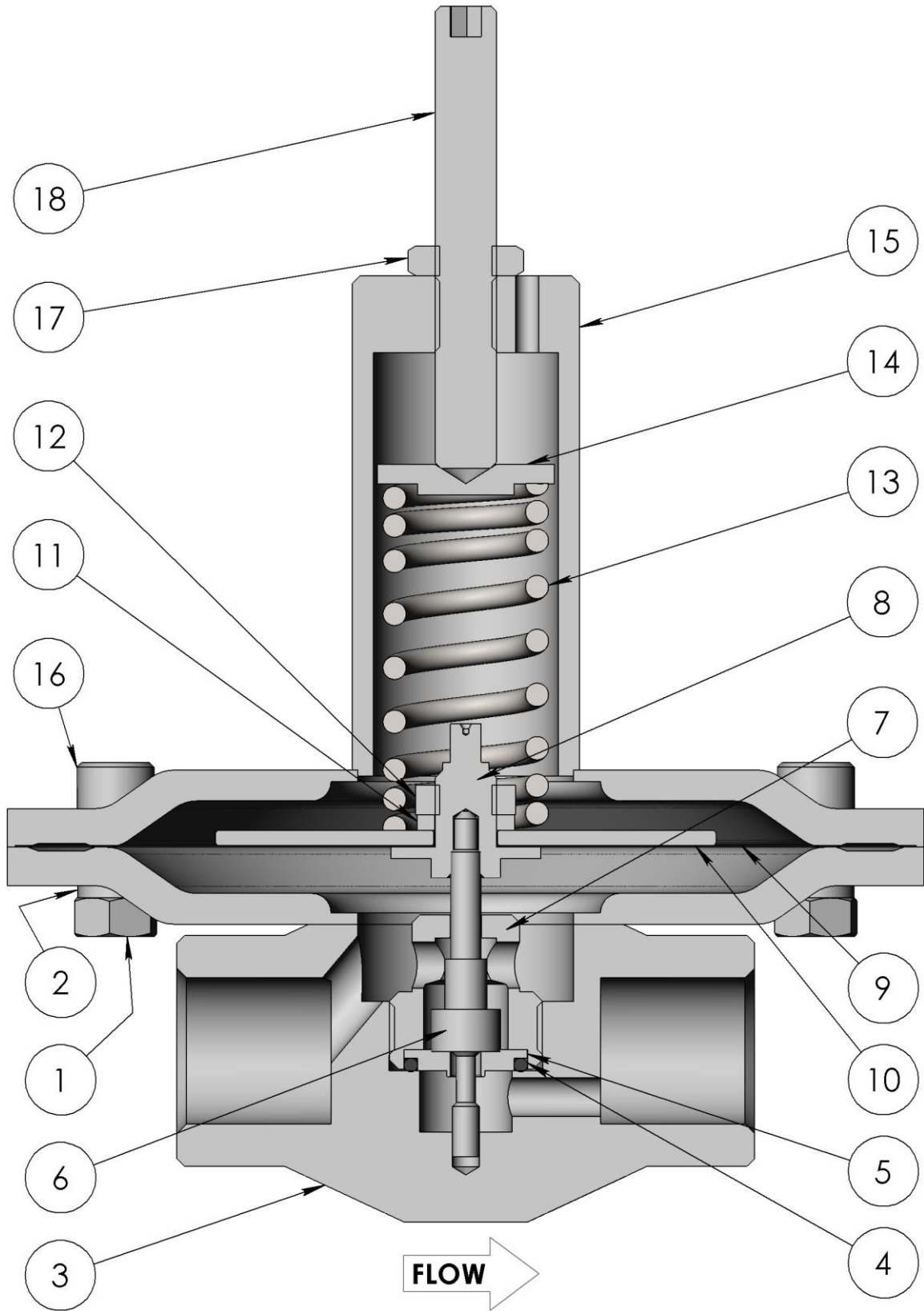

Fig 2

Disassembly

- The following instructions describe how to fully disassemble the regulator for the purposes of maintenance and repair.
 - Note that not all components listed appear in all regulator configurations.
 - Only disassemble the regulator as far as is required to replace the components supplied in the maintenance kit.
 - Discard all components being replaced.
1. Ensure the set screw (18) is backed out and not acting on the set spring (13). It can be fully removed, if required, by unwinding counterclockwise until it detaches from the spring housing assembly (15).
 2. Loosen the cap screws (16) and remove the spring housing assembly (15).
 3. Remove the diaphragm nut (12), lock washer (11), diaphragm plate (10), and diaphragm (9) from the poppet (6).
 4. Unscrew the seat retainer (7) and remove the assembly from the body (3).
 5. Unscrew the clamp ring (8) from the poppet (6).
 6. Remove the seat retainer (7) from the poppet (6).
 7. Remove the seat (5) and seat seal (4) from the body (3).

Points of Attention Before Reassembly

- Visually inspect all components for abnormal wear or damage. Replace components in case of doubt.
- All parts must remain clean and undamaged before starting assembly.
- Maintenance kit components will be supplied preassembled where practicable to aid reassembly.
- Swagelok recommends replacing all O-rings removed during disassembly.



NOTICE

All threaded components must be lightly lubricated per Table 2 before reassembly to avoid galling of threads.

Reassembly

1. Lightly lubricate the central hole of the seat retainer (7).
2. Insert the poppet (6) through the seat retainer (7).
3. Lightly lubricate the poppet thread (6), then fit the clamp ring (8). Torque to 3.5 lbf·ft (5 N·m).
4. Fit the seat (5) and seat seal (4) over the poppet (6) and into the seat retainer (7). Ensure they are oriented correctly per Fig 2.
5. Lightly lubricate the seat retainer thread (7) then install into the body (3).
6. Secure the body (3) in a vise.
7. Torque the seat retainer (7) to 7 lbf·ft (10 N·m).
8. Place the diaphragm (9) then diaphragm plate (10) on to the clamp ring (8).
9. Lightly lubricate the clamp ring thread (8) then retain using the lock washer (11) and nut (12). Torque to 3.5 lbf·ft (5 N·m).
10. Lubricate the central recess of the spring guide (14).
11. Stack the set spring (13) and spring guide (14) onto the diaphragm plate (10).
12. Place the spring housing assembly (15) over the spring (13).
13. Lightly lubricate the cap screws (16). Secure the spring housing assembly (15) to the body (3) using the cap screws (16), washers (2), and nuts (1). Torque to 7 lbf·ft (10 N·m).
14. Lightly lubricate the set screw (18) thread. Fit the nut (17) onto the set screw (18) and install it into the top of the spring housing assembly (15).

Testing

Swagelok recommends that the regulator be tested for seat and shell leakage to atmosphere. A well performing regulator will not show any indication of leaking. If any evidence of a leak is identified this must be rectified. Any damaged components must be replaced.

Seat Leak Test

1. Ensure there is sufficient supply pressure to the regulator to be able to perform the tests.
2. Ensure any downstream shutoff valves are open.
3. Set the regulator to its maximum set pressure then close the supply shutoff valve.
4. Monitor the inlet pressure and/or use liquid leak detector on the outlet port. A drop in inlet pressure over time or bubbles in the leak detector indicates a seat leak.

Shell Leak Test

1. Set the regulator to the open position (i.e. ensure the set screw is fully backed off counterclockwise).
2. Close the downstream shutoff valve.
3. Maintain an inlet pressure of approximately 14.5 psig (1 bar) on the regulator. Measure the outlet pressure to ensure this also reads the same value.
4. Using liquid leak detector, check for bubbles at the spring housing to body interface and the spring housing weep hole.

Troubleshooting

Symptom	Cause	Remedy
Constant leakage from the outlet before the set pressure is reached.	A damaged seat and/or poppet.	Replace the seat and/or poppet.
Leakage between the body and the spring housing.	A damaged diaphragm.	Replace the diaphragm.
	Insufficient torque on the cap screws.	Tighten the cap screws per Table 2.
The required set pressure cannot be reached.	The inlet pressure to the regulator is not high enough.	Ensure that the inlet pressure to the regulator is equal to or greater than the desired set pressure.
The inlet pressure rises too much when going from a dynamic to a static situation.	There is too much flow in the dynamic situation.	A larger regulator or parallel regulator is required. Review application flow capacity and contact your local authorized sales and service center.
The regulator will not relieve at the set point.	The poppet is sticking.	Replace the poppet.
	The set point has been accidentally altered.	Readjust the set point.
The set pressure has changed without adjusting the set screw.	Changes to the outlet pressure may result in changes to the set pressure.	Maintain a constant outlet pressure on the regulator. See “ Points of Attention Before Operation ” about dependency .
	Changes to the flow may result in changes to the set pressure.	Maintain a constant flow through the regulator. See “ Points of Attention Before Operation ” about accumulation .

Table 3

Warranty Information

Swagelok products are backed by The Swagelok Limited Lifetime Warranty.
For a copy, visit swagelok.com or contact your authorized Swagelok representative.

Swagelok, Snoop - TM Swagelok Company
Krytox – TM The Chemours Company
© 2018 Swagelok Company
July 2018, RevA
MS-CRD-0167

The Swagelok logo is rendered in a blue, stylized, cursive font. The letters are connected, and the 'S' and 'W' are particularly prominent. A registered trademark symbol (®) is located at the end of the word.