

Process Interface Valve, VB05 Series

Ball Valve Module Advantages

Performs to Shell MESG SPE 77/300 Tightness Class B for reduced fugitive emissions.

Ball valves act as primary and secondary isolation valves in the VB05 series process interface assemblies.

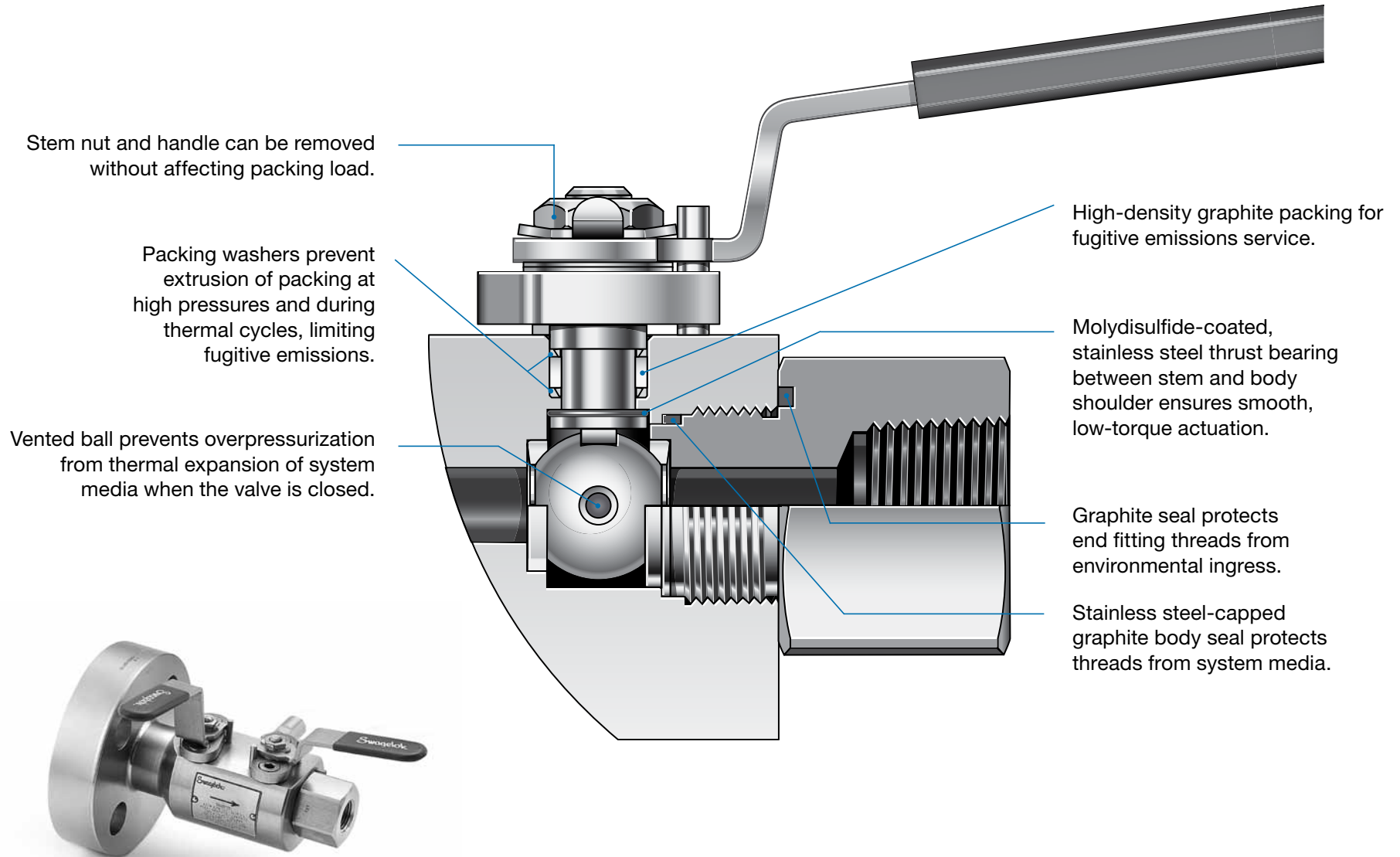

Integral Screwed-Bonnet Needle Valve Module Advantages

Performs to Shell MESG SPE 77/300 Tightness Class B for reduced fugitive emissions.

Integral screwed bonnet needle valves act as the vent valves in the VB05 series process interface assemblies.

