

# Orbital Welding System

Weld Head, Tube and Pipe Collets,  
and Tungsten Electrodes



## Series 40

- Is available for outside tube diameters ranging from 1 1/2 to 4 in. and 38.1 to 114.3 mm and pipe diameters ranging from 1 1/4 to 4 in. and 42.2 to 114.3 mm
- Offers versatility for use in a variety of industries

## Series 40 Weld Head

- Provides an ideal welding solution in the bioprocessing and power industries, among others
- Includes a viewing port, allowing the operator to line up the weld for ultimate reliability; an optional integral welding lens allows the operator to monitor the weld in process.
- Offers optical speed control—no tachometer or calibration required.

### Ordering Information and Dimensions

Dimensions, in inches (millimeters), are for reference only and are subject to change.

Cable Length ft (m)	Ordering Number	Weld Head Weight <sup>①</sup> lb (kg)
15 (4.6)	SWS-40H-D-15	12.8 (5.8)
35 (10.7)	SWS-40H-D-35	
50 (15.2)	SWS-40H-D-50	

Cables attach directly to the Swagelok® M200 power supply. For Swagelok M100 and earlier power supply models, an adapter is required.

Ordering number: **SWS-M100-WH-ADPTR**

① Weight does not include collets or cable.

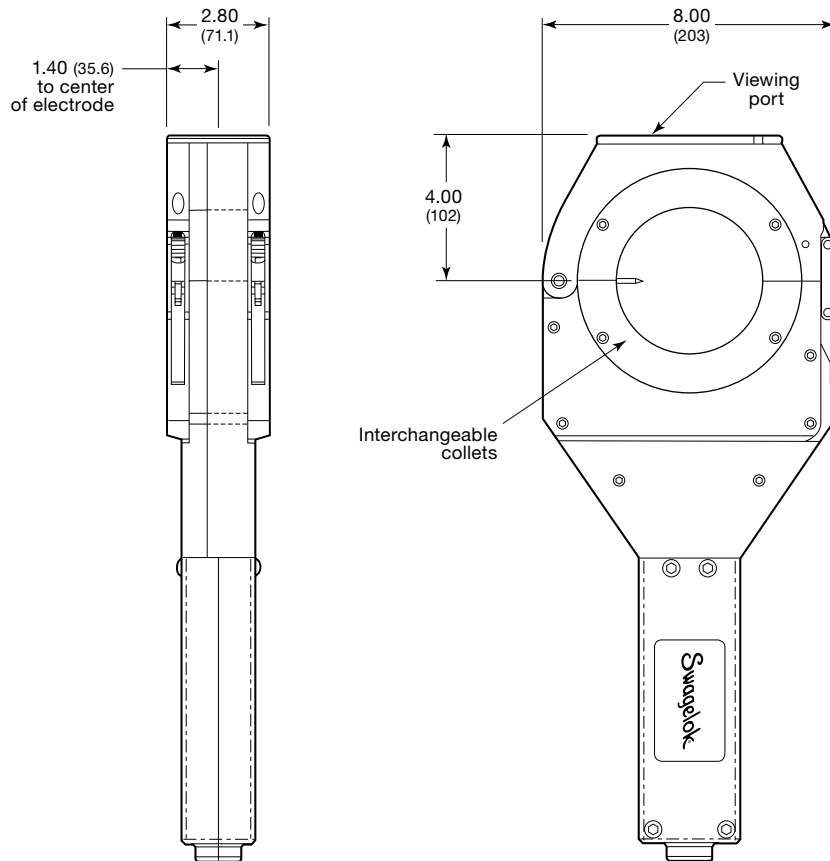

## Tube and Pipe Collets

Two collet halves are required per side plate.

### Tube Collets

- Hold components rigidly during welding.
- Are easily changed for varying outside diameters.



Tube Collet Size		Collet Half Ordering Number
in.	mm	
1 1/2	38.1	SWS-40CI-24
—	42.4	SWS-40CI-42.4MM
	44.5	SWS-40CI-44.5MM
	48.3	SWS-40CI-48.3MM
2	50.8	SWS-40CI-32
—	54.0	SWS-40CI-54MM
	60.3	SWS-40CI-60.3MM
2 1/2	63.5	SWS-40CI-40
3	76.2	SWS-40CI-48
3 1/2	88.9	SWS-40CI-56
4	101.6	SWS-40CI-64
—	104.0	SWS-40CI-104MM
—	114.3	SWS-40CI-114.3MM

### Pipe Collets

- Design compensates for pipe size variation.
- Pre-tacking of weld joint is required.

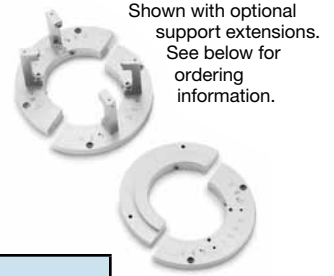

Pipe Collet Size		Collet Half Ordering Number
in.	mm (JIS)	
1 1/4	42.2	SWS-40CI-20P
1 1/2	48.3	SWS-40CI-24P
2	60.3	SWS-40CI-32P
—	60.5 (50A)	SWS-40CI-60.5MMP
2 1/2	73.0	SWS-40CI-40P
—	76.3 (65A)	SWS-40CI-76.3MMP
3	88.9	SWS-40CI-48P
—	89.1 (80A)	SWS-40CI-89.1MMP
3 1/2	101.6 (90A)	SWS-40CI-56P
4	114.3 (100A)	SWS-40CI-64P

### Support Extensions

Use support extensions when welding vertical runs of pipe. The support extensions minimize angular misalignment and provide maximum rigidity. Use in sets of either 4 or 8 pieces.

Description	Ordering Number
Support extension	SWS-40CI-EXT

## Tungsten Electrodes

Swagelok electrodes, available in packages of ten, provide consistent, repeatable welds. Electrodes consist of 2 % ceriated tungsten, axially ground to rigid specifications.



Tube Collet Size		Tungsten Electrodes Ordering Number
in.	mm	
1 1/2	38.1	SWS-C.094-2.615-P
—	42.4	SWS-C.094-2.530-P
	44.5	SWS-C.094-2.489-P
	48.3	SWS-C.094-2.414-P
2	50.8	SWS-C.094-2.365-P
—	54.0	SWS-C.094-2.302-P
	60.3	SWS-C.094-2.178-P
2 1/2	63.5	SWS-C.094-2.115-P
3	76.2	SWS-C.094-1.865-P
3 1/2	88.9	SWS-C.094-1.615-P
4	101.6	SWS-C.094-1.365-P
—	104.0	SWS-C.094-1.318-P
—	114.3	SWS-C.094-1.115-P

Pipe Collet Size		Tungsten Electrodes Ordering Number
in.	mm (JIS)	
1 1/4	42.2	SWS-C.094-2.535-P
1 1/2	48.3	SWS-C.094-2.414-P
2	60.3	SWS-C.094-2.178-P
—	60.5 (50A)	SWS-C.094-2.174-P
2 1/2	73.0	SWS-C.094-1.928-P
—	76.3 (65A)	SWS-C.094-1.863-P
3	88.9	SWS-C.094-1.615-P
—	89.1 (80A)	SWS-C.094-1.611-P
3 1/2	101.6 (90A)	SWS-C.094-1.365-P
4	114.3 (100A)	SWS-C.094-1.115-P

## Options and Accessories

### Weld Head Extension Cables

Swagelok weld head extension cables enable weld head operation away from the M200 power supply, up to a total cable length of 200 ft (61 m).

See the Swagelok *Series 40 Weld Head User's Manual*, MS-13-206, for information on weld head performance with optional weld head extension cables.



Extension Cable ft (m)	Ordering Number
35 (10.7)	SWS-WHEC-D-35
50 (15.2)	SWS-WHEC-D-50

### Weld Head Adapter Cable

The weld head adapter cable allows connection from earlier Swagelok 40H-C model weld heads to the Swagelok M200 power supply.



Ordering number: **SWS-M200-WH-ADPTR**

### Viewing Port Weld Lens

The optional viewing port weld lens allows the operator to monitor the weld in process. The lens is for welding applications of 120 A at 50 % duty cycle or below.

Ordering number: **SWS-WIN-WL-CVR**

#### Safe Product Selection

**When selecting a product, the total system design must be considered to ensure safe, trouble-free performance. Function, material compatibility, adequate ratings, proper installation, operation, and maintenance are the responsibilities of the system designer and user.**

**Caution: Do not mix or interchange parts with those of other manufacturers.**

## Warranty Information

Swagelok products are backed by The Swagelok Limited Lifetime Warranty. For a copy, visit [swagelok.com](http://swagelok.com) or contact your authorized Swagelok representative.