

IGC[®]II Integrated Gas Components

Substrates, Manifolds, Mounting Components,
and Assembly Hardware



IGC II Series

- 1.5 in. (38.1 mm) C-seal modular design
- Compact footprint minimizes space requirements
- Lightweight, easy-to-assemble components

Contents

Technical Data	2
The IGC II System	3
Substrate Channels	4
Substrate Components	
Surface-Mount Connectors	4
Substrate End Connectors	5
Mass Flow Controller Connectors	6
Jumper Tube Connectors	6
Spacer Connectors	7
Drop-Down Connector and Plugs	7
Manifold Channels	7
Manifold Components—Tee Connectors	
Elbow-to-Elbow	8
Elbow-to-“H” Type VCR® Fitting	8
Elbow-to-Butt Weld	8
“H” Type VCR-to-“H” Type VCR Fittings	9
“H” Type VCR Fitting-to-Butt Weld	9
Butt Weld-to-Butt Weld	10
Parallel Manifold Channels.	10
Parallel Manifold Components	
Jumper Tube Connectors	10
Caps and Conversion Plate	11
Support Blocks.	11
Assembly Hardware	12

Technical Data

Service Ratings

- Pressure rating: 3000 psig (206 bar) at 70°F (20°C) for substrate and manifold components
- Temperature rating: 120°C (248°F) operating; 150°C (302°F) bakeout.

Materials of Construction

- Wetted flow components: 316L VIM-VAR stainless steel
- Nonwetted components: aluminum (hard-coat anodized, alloy 2024-T351), stainless steel (316, 303, and alloy A286), and plastic (polyethersulfone)

Internal Surface Finish

- Wetted components: electropolished to 5 µin. (0.13 µm) R_a average

Cleaning and Processing

- Wetted components: Swagelok *Ultrapure-Purity Process Specification (SC-01)*, MS-06-61.

The IGC II System

- A typical IGC II system consists of three layers—a substrate assembly, a manifold assembly, and mounting components.
- The manifold and substrate assemblies are combined to form the conduit for the process gas and can be customized for any flow configuration.
- The IGC II system is assembled with simple mounting components and standard hardware.
- The IGC II system accepts any 1.5 in. (38.1 mm) C-seal surface-mount component. See the Swagelok *Modular Surface-Mount Components and Seals* catalog, MS-02-135, for details.
- The Swagelok *IGC II System Configurator* is available to simplify the layout, selection, and ordering of IGC II components. The *Configurator* can be downloaded from www.swagelok.com.

Substrate Assembly

- The assembly provides the flow path for the process gas through the gas stick.
- The substrate assembly consists of a substrate channel and a variety of drop-in flow components.
- The substrate channels are available in a variety of lengths to accommodate up to 14 surface-mount components.
- See pages 4 through 7 for ordering numbers.

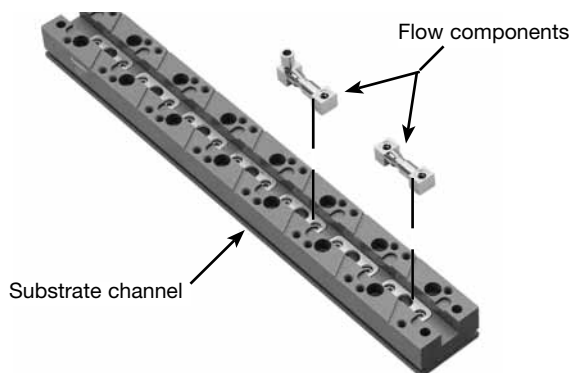

Manifold Assembly

- The manifold assembly provides the flow path *between* two or more parallel gas sticks.
- The manifold assembly consists of a manifold channel and a variety of drop-in flow components.
- The manifold channels are available in a variety of lengths to accommodate up to 10 parallel gas sticks.
- Optional parallel manifold assemblies are available to provide an additional flow path *parallel* to the gas stick.
- See pages 7 through 10 for ordering numbers.

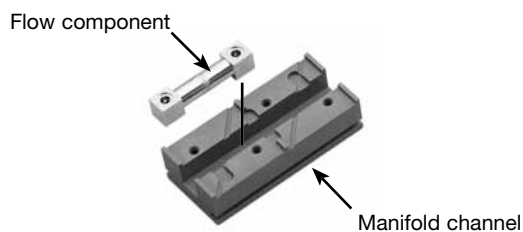

Substrate-Manifold Assembly

- The substrate assembly bolts over the manifold assembly.
- A C-seal gasket assembly (not visible) provides a leak-tight seal between the substrate component and the manifold below.
- The substrate-manifold assembly accepts any 1.5 in. (38.1 mm) C-seal surface-mount component.

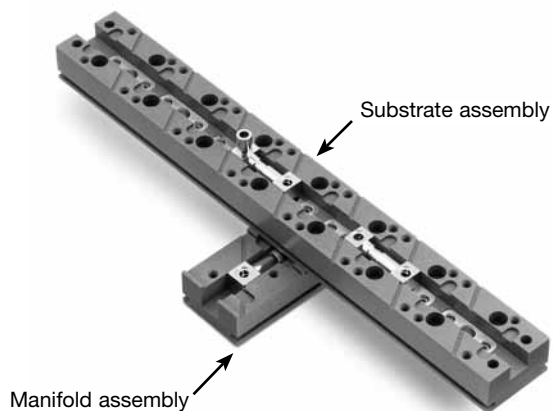

Mounting Components and Caps

- A foot block bolts to each end of the gas stick, providing panel-mount capability.
- A support block provides midline support for longer gas sticks.
- A conversion plate provides the mounting capacity for a mass flow controller.
- A cap is available to cover an unused position on a substrate or manifold.
- A tube port is available to provide a 1/4 in. vertical tube port on a manifold or substrate.
- See pages 11 and 12 for ordering numbers.



Substrate Channels

Dimensions, in inches (millimeters), are for reference only and are subject to change.

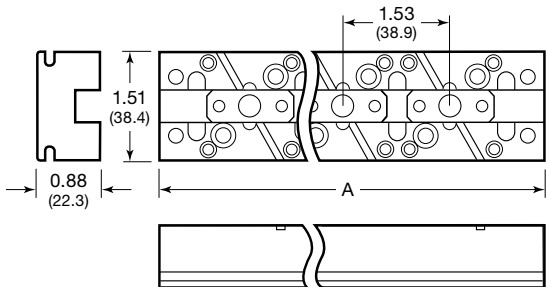

Number of Surface-Mount Positions	Ordering Number	A in. (mm)	Number of Surface Mount Positions	Ordering Number	A in. (mm)
1	A-IG2-SB-01	2.60 (66.0)	8	A-IG2-SB-08	13.3 (338)
2	A-IG2-SB-02	4.13 (105)	9	A-IG2-SB-09	14.8 (376)
3	A-IG2-SB-03	5.66 (144)	10	A-IG2-SB-10	16.4 (416)
4	A-IG2-SB-04	7.19 (183)	11	A-IG2-SB-11	17.9 (455)
5	A-IG2-SB-05	8.72 (221)	12	A-IG2-SB-12	19.4 (493)
6	A-IG2-SB-06	10.2 (259)	13	A-IG2-SB-13	21.0 (533)
7	A-IG2-SB-07	11.8 (300)	14	A-IG2-SB-14	22.5 (572)

Port Descriptions for Substrate Components

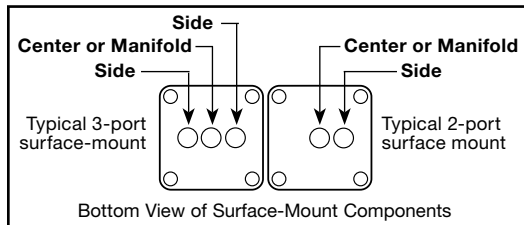

From left to right:
Port 1 corresponds to the connection port on the first surface-mount component.
Port 2 corresponds to the connection port on the second surface-mount component.

Substrate Components

Surface-Mount Connectors

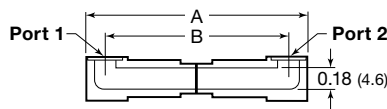

Cutaway	Description		Ordering Number	Dimensions, in. (mm)		Wetted Surface Area in. ² (cm ²)	Internal Volume in. ³ (cm ³)
	Port 1	Port 2		A	B		
	Side	Side	6LVV-IG2-WS-SHSH	1.22 (31.0)	0.92 (23.4)	0.69 (4.4)	0.031 (0.51)
		Center	6LVV-IG2-WS-SHLG	1.53 (38.9)	1.23 (31.2)	0.86 (5.5)	0.039 (0.64)
		Center and manifold	6LVV-IG2-WS-SHDT			1.18 (7.6)	0.054 (0.89)
		Manifold	6LVV-IG2-WS-SHDE			1.15 (7.4)	0.052 (0.85)
	Center	Center	6LVV-IG2-WS-LGLG			1.83 (46.5)	1.53 (38.9)
		Center and manifold	6LVV-IG2-WS-LGDT	1.36 (8.7)	0.062 (1.0)		
		Manifold	6LVV-IG2-WS-LGDE	1.32 (8.5)	0.060 (0.97)		
	Center and manifold	Center and manifold	6LVV-IG2-WS-DTDT	1.83 (46.5)	1.53 (38.9)	1.68 (10.8)	0.078 (1.3)
		Manifold	6LVV-IG2-WS-DTDE			1.65 (10.6)	0.075 (1.2)
	Manifold	Manifold	6LVV-IG2-WS-DEDE	1.83 (46.5)	1.53 (38.9)	1.61 (10.3)	0.073 (1.2)

Substrate Components

Dimensions, in inches (millimeters), are for reference only and are subject to change.

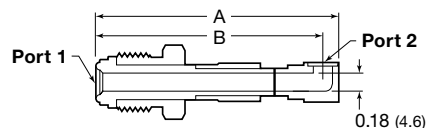

Substrate End Connectors

Cutaway	Description		Ordering Number	Dimensions, in. (mm)		Wetted Surface Area in. ² (cm ²)	Internal Volume in. ³ (cm ³)
	Port 1	Port 2		A	B		
	1/4 in. male VCR fitting	Side	6LVV-IG2-WS-SHVM	2.31 (58.7)	2.16 (54.9)	1.31 (8.4)	0.059 (0.96)
		Center	6LVV-IG2-WS-LGVM	2.61 (66.3)	2.46 (62.5)	1.48 (9.5)	0.067 (1.1)
		Center and manifold	6LVV-IG2-WS-DTVM			1.80 (11.6)	0.082 (1.3)
		Manifold	6LVV-IG2-WS-DEVM	1.77 (11.4)	0.080 (1.3)		
		Standard MFC	6LVV-IG2-WS-VMMA	2.36 (59.9)	2.18 (55.4)	1.54 (9.9)	0.070 (1.1)
		Compact MFC	6LVV-IG2-WS-VMMB	2.60 (66.0)	2.42 (61.5)	1.68 (10.8)	0.076 (1.2)
	1/4 in. female VCR fitting	Side	6LVV-IG2-WS-SHVF	2.31 (58.7)	2.16 (54.9)	1.31 (8.4)	0.059 (0.96)
		Center	6LVV-IG2-WS-LGVF	2.61 (66.3)	2.46 (62.5)	1.48 (9.5)	0.067 (1.1)
		Center and manifold	6LVV-IG2-WS-DTVF			1.80 (11.6)	0.082 (1.3)
		Manifold	6LVV-IG2-WS-DEVF	1.77 (11.4)	0.080 (1.3)		
		Standard MFC	6LVV-IG2-WS-VFMA	2.36 (59.9)	2.18 (55.4)	1.54 (9.9)	0.070 (1.1)
		Compact MFC	6LVV-IG2-WS-VFMB	2.60 (66.0)	2.42 (61.5)	1.68 (10.8)	0.076 (1.2)
	1/4 × 0.035 in. butt weld	Side	6LVV-IG2-WS-SHEC	1.48 (37.6)	1.33 (33.8)	0.84 (5.4)	0.038 (0.62)
		Center	6LVV-IG2-WS-LGEC	1.78 (45.2)	1.63 (41.4)	1.01 (6.5)	0.045 (0.74)
		Center and manifold	6LVV-IG2-WS-DTEC			1.33 (8.6)	0.061 (0.99)
		Manifold	6LVV-IG2-WS-DEEC	1.30 (8.4)	0.059 (0.96)		
		Standard MFC	6LVV-IG2-WS-ECMA	1.53 (38.9)	1.35 (34.3)	1.08 (6.9)	0.048 (0.79)
		Compact MFC	6LVV-IG2-WS-ECMB	1.77 (45.0)	1.59 (40.4)	1.21 (7.8)	0.054 (0.89)

Substrate Components

Dimensions, in inches (millimeters), are for reference only and are subject to change.

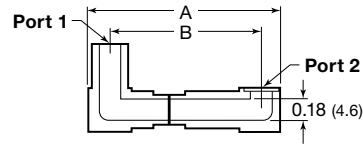

Mass Flow Controller Connectors

Cutaway	Description		Ordering Number	Dimensions, in. (mm)		Wetted Surface Area in. ² (cm ²)	Internal Volume in. ³ (cm ³)
	Port 1	Port 2		A	B		
	Standard MFC	Side	6LVV-IG2-WS-SHMA	1.27 (32.2)	0.94 (23.9)	0.93 (5.9)	0.042 (0.68)
		Center	6LVV-IG2-WS-LGMA			1.10 (7.1)	0.050 (0.81)
		Center and manifold	6LVV-IG2-WS-DTMA	1.58 (40.1)	1.25 (31.8)	1.42 (9.2)	0.065 (1.1)
		Manifold	6LVV-IG2-WS-DEMA			1.39 (8.9)	0.063 (1.0)
		Standard MFC	6LVV-IG2-WS-MAMA	1.33 (33.8)	0.97 (24.6)	1.17 (7.5)	0.053 (0.87)
		Compact MFC	6LVV-IG2-WS-MAMB	1.58 (40.1)	1.21 (30.7)	1.30 (8.4)	0.059 (0.97)
	Compact MFC	Side	6LVV-IG2-WS-SHMB	1.51 (38.4)	1.18 (30.0)	1.06 (6.8)	0.048 (0.78)
		Center	6LVV-IG2-WS-LGMB			1.23 (7.9)	0.056 (0.91)
		Center and manifold	6LVV-IG2-WS-DTMB	1.82 (46.2)	1.49 (37.8)	1.56 (10.0)	0.071 (1.2)
		Manifold	6LVV-IG2-WS-DEMB			1.52 (9.8)	0.069 (1.1)
		Compact MFC	6LVV-IG2-WS-MBMB	1.83 (46.5)	1.45 (36.8)	1.43 (9.2)	0.065 (1.1)

Jumper Tube Connectors

Number of Surface-Mount Positions Skipped	Ordering Number	Dimensions, in. (mm)		Wetted Surface Area in. ² (cm ²)	Internal Volume in. ³ (cm ³)
		A	B		
1	6LVV-IG2-WS-SHTB01LG	3.06 (77.7)	2.76 (70.1)	1.73 (11.1)	0.078 (1.3)
2	6LVV-IG2-WS-SHTB02LG	4.59 (116)	4.28 (109)	2.59 (16.7)	0.12 (1.9)
3	6LVV-IG2-WS-SHTB03LG	6.12 (155)	5.82 (148)	3.46 (22.3)	0.16 (2.5)
4	6LVV-IG2-WS-SHTB04LG	7.65 (194)	7.34 (186)	4.32 (27.9)	0.20 (3.2)
5	6LVV-IG2-WS-SHTB05LG	9.18 (233)	8.88 (226)	5.19 (33.5)	0.23 (3.8)
6	6LVV-IG2-WS-SHTB06LG	10.7 (272)	10.4 (264)	6.05 (39.0)	0.27 (4.5)
7	6LVV-IG2-WS-SHTB07LG	12.2 (310)	11.9 (302)	6.92 (44.6)	0.31 (5.1)
8	6LVV-IG2-WS-SHTB08LG	13.8 (350)	13.5 (343)	7.78 (50.2)	0.35 (5.7)
9	6LVV-IG2-WS-SHTB09LG	15.3 (389)	15.0 (381)	8.65 (55.8)	0.39 (6.4)
10	6LVV-IG2-WS-SHTB010LG	16.8 (427)	16.5 (419)	9.51 (61.4)	0.43 (7.0)

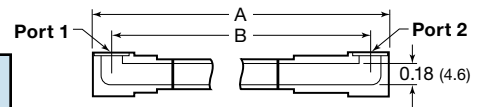

Substrate Components

Dimensions, in inches (millimeters), are for reference only and are subject to change.

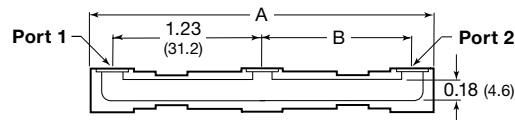

Spacer Connectors

Cutaway	Description		Ordering Number	Dimensions, in. (mm)		Wetted Surface Area in. ² (cm ²)	Internal Volume in. ³ (cm ³)
	Port 1	Port 2		A	B		
	Side	Side	6LVV-IG2-WS-SHTASH	2.75 (69.9)	1.23 (31.2)	1.06 (10.3)	0.072 (1.2)
	Side	Center	6LVV-IG2-WS-SHTALG	3.06 (77.7)	1.53 (38.9)	1.77 (11.4)	0.080 (1.3)

Drop-Down Connector and Plugs

Cutaway	Description	Ordering Number	A in. (mm)	Wetted Surface Area in. ² (cm ²)	Internal Volume in. ³ (cm ³)
	Drop-down connector for substrate-to-manifold connection	6LVV-IG2-WC-DD	0.86 (21.8)	0.49 (3.2)	0.022 (0.36)
	Plug for manifold port with a substrate component above	6LVV-IG2-WC-PG	0.50 (12.7)	0.030 (0.19)	—
	Plug for manifold port with no substrate component above	6LVV-IG2-WC-DP	0.86 (21.8)	0.030 (0.19)	—



Manifold Channels

Dimensions, in inches (millimeters), are for reference only and are subject to change.

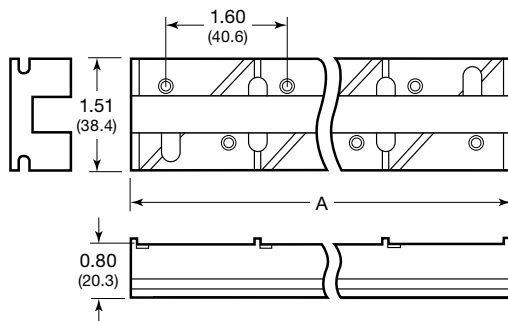

Number of Surface Mount Positions	Ordering Number	A in. (mm)
1	A-IG2-MB-01	1.68 (42.7)
2	A-IG2-MB-02	3.28 (83.3)
3	A-IG2-MB-03	4.88 (124)
4	A-IG2-MB-04	6.48 (164)
5	A-IG2-MB-05	8.08 (205)
6	A-IG2-MB-06	9.68 (246)
7	A-IG2-MB-07	11.3 (287)
8	A-IG2-MB-08	12.9 (328)
9	A-IG2-MB-09	14.5 (368)
10	A-IG2-MB-10	16.1 (409)

Manifold Components—Tee Connectors

Dimensions, in inches (millimeters), are for reference only and are subject to change.

Elbow-to-Elbow

Number of Surface Mount Positions Skipped	Ordering Number	A in. (mm)	Wetted Surface Area in. ² (cm ²)	Internal Volume in. ³ (cm ³)
2	6LVV-IG2-MS-MEME	2.04 (51.8)	1.59 (10.3)	0.10 (1.7)
3	6LVV-IG2-MS-MEMT01ME	3.64 (92.5)	3.15 (20.3)	0.22 (3.7)
4	6LVV-IG2-MS-MEMT02ME	5.24 (133)	4.68 (30.2)	0.34 (5.6)
5	6LVV-IG2-MS-MEMT03ME	6.84 (174)	6.23 (40.2)	0.46 (7.5)
6	6LVV-IG2-MS-MEMT04ME	8.44 (214)	7.76 (50.1)	0.58 (9.5)
7	6LVV-IG2-MS-MEMT05ME	10.0 (254)	9.30 (60.0)	0.70 (11.4)
8	6LVV-IG2-MS-MEMT06ME	11.6 (295)	10.9 (70.0)	0.82 (13.4)
9	6LVV-IG2-MS-MEMT07ME	13.2 (335)	12.4 (80.0)	0.93 (15.3)
10	6LVV-IG2-MS-MEMT08ME	14.8 (376)	13.9 (89.9)	1.05 (17.2)

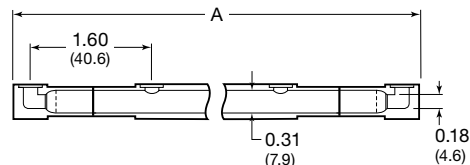

Elbow-to-“H” Type VCR Fittings

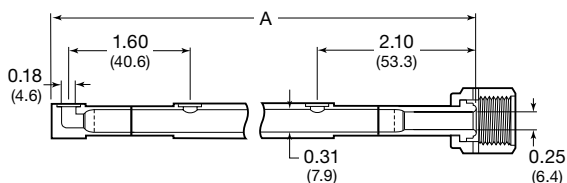

Female VCR Fitting

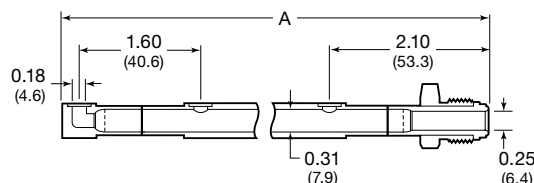

Male VCR Fitting

Number of Surface Mount Positions	Female VCR Fitting Ordering Number	Male VCR Fitting Ordering Number	A in. (mm)	Wetted Surface Area in. ² (cm ²)	Internal Volume in. ³ (cm ³)
1	6LVV-IG2-MS-MEMF	6LVV-IG2-MS-MEMM	2.32 (58.9)	1.86 (12.0)	0.12 (2.0)
2	6LVV-IG2-MS-MEMT01MF	6LVV-IG2-MS-MEMT01MM	3.92 (99.6)	3.41 (22.0)	0.24 (4.0)
3	6LVV-IG2-MS-MEMT02MF	6LVV-IG2-MS-MEMT02MM	5.52 (140)	4.94 (31.9)	0.36 (5.9)
4	6LVV-IG2-MS-MEMT03MF	6LVV-IG2-MS-MEMT03MM	7.12 (181)	6.49 (41.8)	0.48 (7.9)
5	6LVV-IG2-MS-MEMT04MF	6LVV-IG2-MS-MEMT04MM	8.72 (221)	8.03 (51.8)	0.60 (9.8)
6	6LVV-IG2-MS-MEMT05MF	6LVV-IG2-MS-MEMT05MM	10.3 (262)	9.57 (61.7)	0.72 (11.7)
7	6LVV-IG2-MS-MEMT06MF	6LVV-IG2-MS-MEMT06MM	11.9 (302)	11.1 (71.7)	0.84 (13.7)
8	6LVV-IG2-MS-MEMT07MF	6LVV-IG2-MS-MEMT07MM	13.5 (343)	12.7 (81.7)	0.95 (15.6)
9	6LVV-IG2-MS-MEMT08MF	6LVV-IG2-MS-MEMT08MM	15.1 (384)	14.2 (91.9)	1.07 (17.6)
10	6LVV-IG2-MS-MEMT09MF	6LVV-IG2-MS-MEMT09MM	16.7 (424)	15.7 (102)	1.19 (19.5)

Elbow-to-Butt Weld

Number of Surface Mount Positions	Ordering Number	A in. (mm)	Wetted Surface Area in. ² (cm ²)	Internal Volume in. ³ (cm ³)
1	6LVV-IG2-MS-MEMC	1.02 (25.9)	0.80 (5.1)	0.052 (0.86)
2	6LVV-IG2-MS-MEMT01MC	2.62 (66.5)	2.35 (15.2)	0.17 (2.81)
3	6LVV-IG2-MS-MEMT02MC	4.22 (107)	3.88 (25.1)	0.29 (4.73)
4	6LVV-IG2-MS-MEMT03MC	5.82 (148)	5.43 (35.0)	0.41 (6.68)
5	6LVV-IG2-MS-MEMT04MC	7.42 (188)	6.97 (45.0)	0.53 (8.62)
6	6LVV-IG2-MS-MEMT05MC	9.02 (229)	8.51 (54.9)	0.64 (10.6)
7	6LVV-IG2-MS-MEMT06MC	10.6 (269)	10.1 (64.9)	0.76 (12.5)
8	6LVV-IG2-MS-MEMT07MC	12.2 (310)	11.6 (74.8)	0.88 (14.5)
9	6LVV-IG2-MS-MEMT08MC	13.8 (350)	13.1 (84.8)	1.00 (16.4)
10	6LVV-IG2-MS-MEMT09MC	15.4 (391)	14.7 (94.7)	1.12 (18.3)

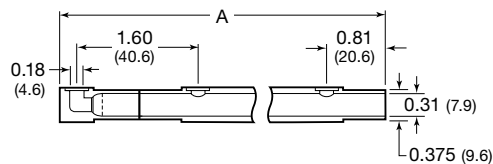

Manifold Components—Tee Connectors

Dimensions, in inches (millimeters), are for reference only and are subject to change.

“H” Type VCR Fitting-to-“H” Type VCR Fitting

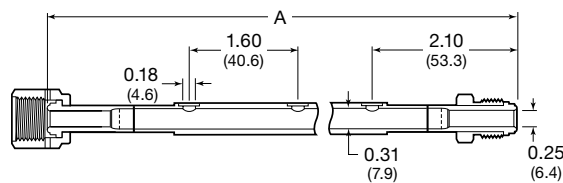

Female-to-Male

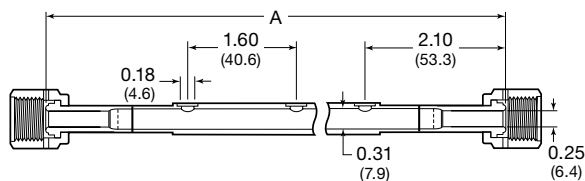

Female-to-Female

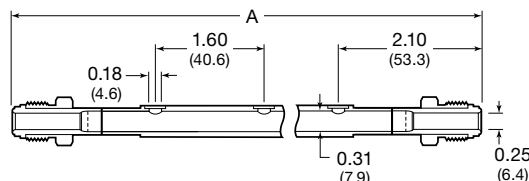

Male-to-Male

Number of Surface Mount Positions	Female-to-Female Ordering Number	Female-to-Male Ordering Number	Male-to-Male Ordering Number	A in. (mm)	Wetted Surface Area in. ² (cm ²)	Internal Volume in. ³ (cm ³)
1	6LVV-IG2-MS-MFMT01MF	6LVV-IG2-MS-MFMT01MM	6LVV-IG2-MS-MMMT01MM	4.21 (107)	3.68 (23.7)	0.26 (4.24)
2	6LVV-IG2-MS-MFMT02MF	6LVV-IG2-MS-MFMT02MM	6LVV-IG2-MS-MMMT02MM	5.81 (148)	5.24 (33.8)	0.38 (6.21)
3	6LVV-IG2-MS-MFMT03MF	6LVV-IG2-MS-MFMT03MM	6LVV-IG2-MS-MMMT03MM	7.41 (188)	6.80 (43.8)	0.50 (8.18)
4	6LVV-IG2-MS-MFMT04MF	6LVV-IG2-MS-MFMT04MM	6LVV-IG2-MS-MMMT04MM	9.01 (229)	8.36 (53.9)	0.62 (10.1)
5	6LVV-IG2-MS-MFMT05MF	6LVV-IG2-MS-MFMT05MM	6LVV-IG2-MS-MMMT05MM	10.6 (269)	9.91 (63.9)	0.74 (12.1)
6	6LVV-IG2-MS-MFMT06MF	6LVV-IG2-MS-MFMT06MM	6LVV-IG2-MS-MMMT06MM	12.2 (310)	11.5 (74.0)	0.86 (14.1)
7	6LVV-IG2-MS-MFMT07MF	6LVV-IG2-MS-MFMT07MM	6LVV-IG2-MS-MMMT07MM	13.8 (350)	13.0 (84.1)	0.96 (16.1)
8	6LVV-IG2-MS-MFMT08MF	6LVV-IG2-MS-MFMT08MM	6LVV-IG2-MS-MMMT08MM	15.4 (391)	14.6 (94.1)	1.10 (18.0)
9	6LVV-IG2-MS-MFMT09MF	6LVV-IG2-MS-MFMT09MM	6LVV-IG2-MS-MMMT09MM	17.0 (432)	16.2 (104)	1.22 (20.0)
10	6LVV-IG2-MS-MFMT10MF	6LVV-IG2-MS-MFMT10MM	6LVV-IG2-MS-MMMT10MM	18.6 (472)	17.7 (114)	1.35 (22.0)

“H” Type VCR Fitting-to-Butt Weld

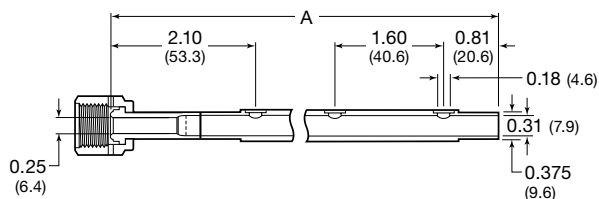

Female VCR Fitting

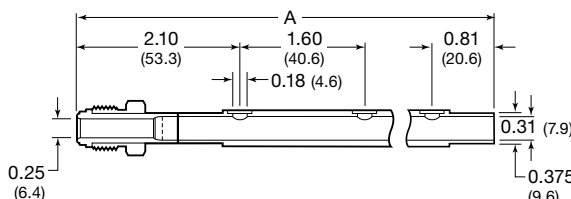

Male VCR Fitting

Number of Surface Mount Positions	Female VCR Fitting Ordering Number	Male VCR Fitting Ordering Number	A in. (mm)	Wetted Surface Area in. ² (cm ²)	Internal Volume in. ³ (cm ³)
1	6LVV-IG2-MS-MFMT01MC	6LVV-IG2-MS-MMMT01MC	2.91 (73.9)	1.06 (6.80)	0.07 (1.17)
2	6LVV-IG2-MS-MFMT02MC	6LVV-IG2-MS-MMMT02MC	4.51 (114)	2.61 (16.8)	0.19 (3.12)
3	6LVV-IG2-MS-MFMT03MC	6LVV-IG2-MS-MMMT03MC	6.11 (155)	4.14 (26.7)	0.31 (5.05)
4	6LVV-IG2-MS-MFMT04MC	6LVV-IG2-MS-MMMT04MC	7.71 (196)	5.69 (36.7)	0.43 (7.00)
5	6LVV-IG2-MS-MFMT05MC	6LVV-IG2-MS-MMMT05MC	9.31 (236)	7.23 (46.6)	0.55 (8.93)
6	6LVV-IG2-MS-MFMT06MC	6LVV-IG2-MS-MMMT06MC	10.9 (277)	8.77 (56.6)	0.66 (10.9)
7	6LVV-IG2-MS-MFMT07MC	6LVV-IG2-MS-MMMT07MC	12.5 (318)	10.3 (66.6)	0.78 (12.8)
8	6LVV-IG2-MS-MFMT08MC	6LVV-IG2-MS-MMMT08MC	14.1 (358)	11.8 (76.5)	0.90 (14.8)
9	6LVV-IG2-MS-MFMT09MC	6LVV-IG2-MS-MMMT09MC	15.7 (399)	13.4 (86.5)	1.02 (16.7)
10	6LVV-IG2-MS-MFMT10MC	6LVV-IG2-MS-MMMT10MC	17.3 (439)	14.9 (96.4)	1.14 (18.6)

Manifold Components—Tee Connectors

Dimensions, in inches (millimeters), are for reference only and are subject to change.

Butt Weld-to-Butt Weld

Number of Surface Mount Positions	Ordering Number	A		Wetted Surface Area in. ² (cm ²)	Internal Volume in. ³ (cm ³)		
		in.	(mm)				
1	6LVV-IG2-MS-MCMT01MC	1.61	(40.9)	1.55	(10.0)	0.12	(2.0)
2	6LVV-IG2-MS-MCMT02MC	3.21	(81.5)	3.09	(19.9)	0.24	(3.9)
3	6LVV-IG2-MS-MCMT03MC	4.81	(122)	4.63	(29.9)	0.36	(5.8)
4	6LVV-IG2-MS-MCMT04MC	6.41	(163)	6.17	(39.8)	0.47	(7.8)
5	6LVV-IG2-MS-MCMT05MC	8.01	(203)	7.71	(49.7)	0.59	(9.7)
6	6LVV-IG2-MS-MCMT06MC	9.61	(244)	9.26	(59.8)	0.71	(11.7)
7	6LVV-IG2-MS-MCMT07MC	11.2	(284)	10.8	(69.7)	0.83	(13.6)
8	6LVV-IG2-MS-MCMT08MC	12.8	(325)	12.3	(79.6)	0.95	(15.5)
9	6LVV-IG2-MS-MCMT09MC	14.4	(366)	12.3	(79.6)	1.07	(17.5)
10	6LVV-IG2-MS-MCMT10MC	16.0	(406)	15.4	(99.5)	1.18	(19.4)

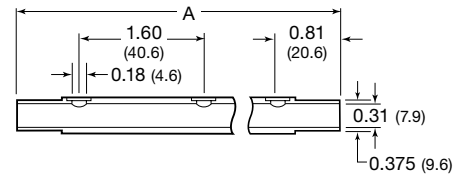

Parallel Manifold Channels

Dimensions, in inches (millimeters), are for reference only and are subject to change.

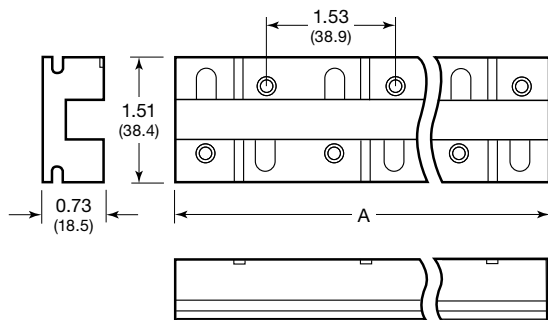

Number of Surface Mount Positions	Ordering Number	A in. (mm)
1	A-IG2-PB-03	4.47 (114)
2	A-IG2-PB-04	6.00 (152)
3	A-IG2-PB-05	7.53 (191)
4	A-IG2-PB-06	9.06 (230)
5	A-IG2-PB-07	10.6 (269)
6	A-IG2-PB-08	12.1 (307)
7	A-IG2-PB-09	13.6 (345)
8	A-IG2-PB-10	15.2 (386)
9	A-IG2-PB-11	16.7 (424)
10	A-IG2-PB-12	18.2 (462)

Parallel Manifold Components

Dimensions, in inches (millimeters), are for reference only and are subject to change.

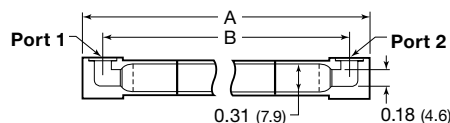

Jumper Tube Connectors

Number of Surface-Mount Positions	Ordering Number	Dimensions, in. (mm)		Wetted Surface Area in. ² (cm ²)	Internal Volume in. ³ (cm ³)
		A	B		
3	6LVV-IG2-MS-MEPT01ME	3.50 (88.9)	3.06 (77.7)	3.00 (19.4)	0.21 (3.5)
4	6LVV-IG2-MS-MEPT02ME	5.03 (128)	4.59 (116)	4.47 (28.8)	0.32 (5.3)
5	6LVV-IG2-MS-MEPT03ME	6.56 (167)	6.12 (155)	5.94 (38.3)	0.44 (7.1)
6	6LVV-IG2-MS-MEPT04ME	8.09 (205)	7.65 (194)	7.41 (47.8)	0.55 (9.0)
7	6LVV-IG2-MS-MEPT05ME	9.62 (244)	9.18 (233)	8.87 (57.3)	0.66 (10.8)
8	6LVV-IG2-MS-MEPT06ME	11.1 (282)	10.7 (272)	10.3 (66.7)	0.77 (12.7)
9	6LVV-IG2-MS-MEPT07ME	12.7 (322)	12.2 (310)	11.8 (76.2)	0.88 (14.5)
10	6LVV-IG2-MS-MEPT08ME	14.2 (361)	13.8 (350)	13.3 (85.7)	1.01 (16.3)
11	6LVV-IG2-MS-MEPT09ME	15.7 (399)	15.3 (389)	14.8 (95.1)	1.11 (18.2)
12	6LVV-IG2-MS-MEPT10ME	17.3 (439)	16.8 (427)	16.2 (105)	1.22 (20.0)

Caps and Conversion Plate

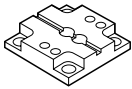
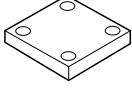
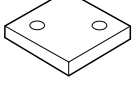
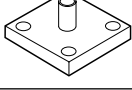
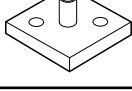

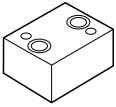
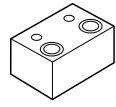
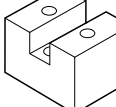

Item	Description	Ordering Number	Function	Material
	Conversion plate	6LVV-IG2-DM-01	Provides mounting capability for MFC	316L VIM-VAR SS
	Substrate cap	6LVV-IG2-DM-04	Covers unused position on substrate	
	Manifold cap	6LVV-IG2-DM-05	Covers unused position on manifold	
	Substrate tube port	6LVV-IG2-DM-06	Provides a vertical tube port on a substrate	
	Manifold tube port	6LVV-IG2-DM-07	Provides a vertical tube port on a manifold	

Support Blocks

Item	Description	Ordering Number	Function	Material
	Support	A-IG2-MH-01	Bolts to bottom of a substrate to provide midline support to a substrate channel with five or more positions	Aluminum alloy 2024-T351
	Foot	A-IG2-MH-02	Bolts to each end of a gas stick to provide mounting capability to the base plate ^①	
	Tube support	A-IG2-MH-15	Adapts the Swagelok tube support system to the center line of the substrate	

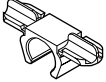
① The base plate is a customer-supplied plate to which the assembled gas stick(s) is mounted.

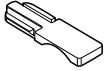
Assembly Hardware

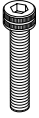
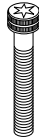
Item	Description	Ordering Number	Function	Material
	Lock-down plate	SS-IG2-MH-03	Secures the substrate components at each end of the substrate channel	303 SS
	Substrate clip	PES-IG2-MH-04	Provides horizontal alignment of substrate components in a channel	Polyethersulfone
	Manifold clip 1	PES-IG2-MH-05	Provides horizontal alignment of manifold components in a channel	Polyethersulfone
	Manifold clip 2	PES-IG2-MH-17	Provides horizontal alignment of manifold end connections and parallel manifold components in a channel	Polyethersulfone
	C-seal gasket assembly	SS-IG2-MH-07	Provides seal between a substrate drop-down component and the manifold	316L SS
 Hex socket cap screw  Torx head cap screw	Hex socket cap screw, 10-32 × 0.50 in.	A286-IG2-MH-10	Secures MFC conversion plate to substrate assembly	Alloy A286
	Torx® head cap screw, 10-32 × 0.75 in.	A286-IG2-MH-11	Secures surface mount ^① to substrate assembly	
	Hex socket cap screw, 10-32 × 1.00 in.	A286-IG2-MH-12	Secures substrate assembly to manifold assembly	
	Torx head cap screw, 10-32 × 1.25 in.	A286-IG2-MH-13	Secures MFC component with 25 or 26 mm flange thickness to MFC conversion plate	
	Hex socket cap screw, 10-32 × 1.375 in.	A286-IG2-MH-20	Secures substrate assembly to foot	
	Torx head cap screw, 10-32 × 1.50 in.	A286-IG2-MH-25	Secures MFC component with 32 mm flange thickness to MFC conversion plate	
	Hex socket cap screw, 1/4-20 × 0.75 in.	SS-IG2-MH-14	Secures foot to base plate	303 SS

① Designed for use with 1.5 in. (38.1 mm) surface-mount components with a 0.312 in. (7.9 mm) base thickness.

Safe Product Selection

When selecting a product, the total system design must be considered to ensure safe, trouble-free performance. Function, material compatibility, adequate ratings, proper installation, operation, and maintenance are the responsibilities of the system designer and user.

Caution: Do not mix or interchange surface-mount component parts with those of other manufacturers.

Warranty Information

Swagelok products are backed by The Swagelok Limited Lifetime Warranty. For a copy, visit swagelok.com or contact your authorized Swagelok representative.

Swagelok, IGC, VCR—TM Swagelok Company
Torx—TM Textron Inc.
© 2012–2013 Swagelok Company
Printed in U.S.A. AGS
MS-02-134, R5