

# Lift Check Valves

## 50 Series

Swagelok® lift check valves limit reverse flow under pressures up to 6000 psig (413 bar) and temperatures up to 900°F (482°C).

Forward flow lifts the poppet, opening the valve. Reverse flow seats the poppet against the orifice, closing the valve.

**The lift check valve is gravity assisted and must be mounted horizontally, with bonnet nut on top.**

### Features

- Rugged, all-stainless steel construction
- Reverse flow coefficient less than 0.1 % of forward flow coefficient
- No springs or elastomers
- Compact size

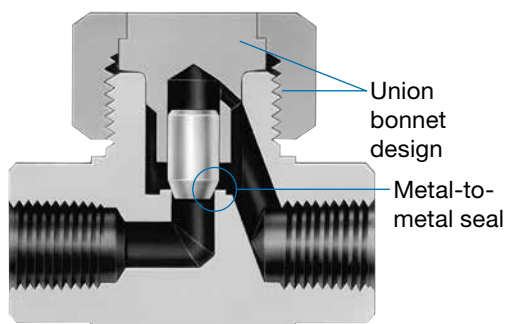

### Pressure-Temperature Ratings

ASME Class	2500
Material Group	2.2
Material Name	316 SS
Temperature °F (°C)	Working Pressure psig (bar)
-65 (-53) to 100 (37)	6000 (413)
200 (93)	5160 (355)
250 (121)	4910 (338)
300 (148)	4660 (321)
350 (176)	4470 (307)
400 (204)	4280 (294)
450 (232)	4130 (284)
500 (260)	3980 (274)
600 (315)	3760 (259)
650 (343)	3700 (254)
700 (371)	3600 (248)
750 (398)	3520 (242)
800 (426)	3460 (238)
850 (454)	3380 (232)
900 (482)	3280 (225)

For more information about pressure ratings of valves with tube fitting end connections, see *Swagelok Tubing Data* (MS-01-107).

### Materials of Construction



Component	Material Grade/ ASTM Specification
1 Bonnet nut	316 SS/A479
2 Bonnet	316 SS/A479
3 Poppet	S17400/A564
4 Body	316 SS/A479
Lubricant	Nickel-based

Wetted components listed in *italics*.

### Testing

Every Swagelok lift check valve is factory tested for proper operation.

### Cleaning and Packaging

All Swagelok lift check valves are cleaned and packaged in accordance with *Swagelok Standard Cleaning and Packaging (SC-10)* (MS-06-62).

### Oxygen Service Hazards

For more information about hazards and risks of oxygen-enriched systems, see the *Swagelok Oxygen System Safety* technical report (MS-06-13).

## Flow Data at 100°F (37°C)

### Air

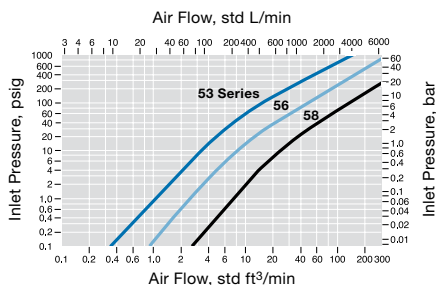

### Water

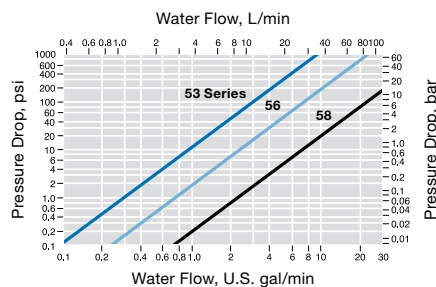

## Options

### Special Cleaning and Packaging (SC-11)

To order lift check valves cleaned and packaged in accordance with *Special Cleaning and Packaging (SC-11)* (MS-06-63), to ensure compliance with product cleanliness requirements stated in ASTM G93 Level C, add **-SC11** to the valve ordering number.

Example: SS-53S4-SC11

### Special Alloys

Many valve bodies are available in other alloys. Contact your authorized Swagelok sales and service representative for more information.

## Ordering Information and Dimensions

Select an ordering number.

Dimensions are for reference only and are subject to change.

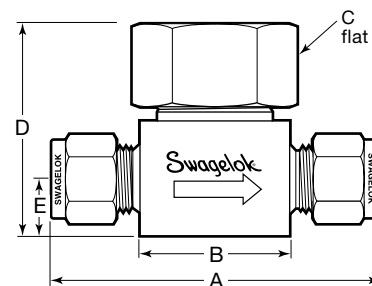

End Connections		C <sub>v</sub>	Orifice in. (mm)	Ordering Number	Series	Dimensions, in. (mm)				
Inlet/Outlet	Size					A	B	C	D	E
Swagelok tube fittings	1/4 in.	0.30	0.156 (4.0)	SS-53S4	53	2.40 (61.0)	1.01 (25.7)	7/8	1.47 (37.3)	0.39 (9.9)
	3/8 in.	0.64	0.250 (6.4)	SS-56S6	56	2.83 (71.9)	1.31 (33.3)	1 1/4	1.85 (47.0)	0.50 (12.7)
	1/2 in.	2.20	0.437 (11.1)	SS-58S8	58	3.92 (99.6)	2.19 (55.6)	1 1/2	2.44 (62.0)	0.62 (15.7)
	3/4 in.			SS-58S12						
	6 mm	0.30	0.156 (4.0)	SS-53S6MM	53	2.40 (61.0)	1.01 (25.7)	7/8	1.47 (37.3)	0.39 (9.9)
Female NPT	1/8 in.	0.30	0.156 (4.0)	SS-53F2	53	2.00 (50.8)	1.00 (25.4)	7/8	1.47 (37.3)	0.39 (9.9)
	1/4 in.			SS-53F4		2.06 (52.3)	0.94 (23.9)			
	1/4 in.	0.64	0.250 (6.4)	SS-56F4	56	2.25 (57.2)	1.25 (31.8)	1 1/4	1.85 (47.0)	0.50 (12.7)
	3/8 in.	2.20	0.437 (11.1)	SS-58F6	58	3.12 (79.2)	1.86 (47.2)	1 1/2	2.44 (62.0)	0.62 (15.7)
	1/2 in.			SS-58F8						
Tube socket weld or pipe butt weld	1/4 in.	0.30	0.156 (4.0)	SS-53SW4T	53	1.81 (46.0)	0.90 (22.9)	7/8	1.47 (37.3)	0.39 (9.9)
	3/8 in.	0.64	0.250 (6.4)	SS-56SW6T	56	2.25 (57.2)	1.25 (31.8)	1 1/4	1.85 (47.0)	0.50 (12.7)
	1/2 in.			SS-56SW8T						
	1/2 in.	2.20	0.437 (11.1)	SS-58SW8T	58	3.13 (79.5)	1.88 (47.8)	1 1/2	2.44 (62.0)	0.62 (15.7)
Swagelok tube fitting/ female NPT	1/4 in.	0.30	0.156 (4.0)	SS-53S4-F4	53	2.23 (56.6)	0.97 (24.6)	7/8	1.47 (37.3)	0.39 (9.9)

Dimensions shown with Swagelok nuts finger-tight.

## Sour Gas Service

Lift check valves are available for sour gas service. Materials are selected in accordance with NACE MR0175/ISO 15156.

### Technical Data

#### Pressure Rating at 70°F (20°C)

6000 psig (413 bar)

#### Temperature Rating

-65 to 500°F (-53 to 260°C)

### Materials of Construction

Poppet—alloy 400/B164

All other materials and lubricant same as standard product. See **Materials of Construction**, page 1.

**Caution: Do not mix or interchange parts with those of other manufacturers.**

## About this document

Thank you for downloading this electronic catalog, which is part of General Product catalog Swagelok published in print. This type of electronic catalog is updated as new information arises or revisions, which may be more current than the printed version.

Swagelok Company is a major developer and provider of fluid system solutions, including products, integration solutions and services for industry research, instrumentation, pharmaceutical, oil and gas, power, petrochemical, alternative fuels, and semiconductor. Our manufacturing facilities, research, service and distribution facilities support a global network of more than 200 authorized sales and service centers in 57 countries.

Visit [www.swagelok.com](http://www.swagelok.com) to locate your Swagelok representative and obtain any information on features, technical information and product references, or to learn about the variety of services available only through authorized sales centers and service Swagelok.

### Safe Product Selection

**When selecting a product, the total system design must be considered to ensure safe, trouble-free performance. Function, material compatibility, adequate ratings, proper installation, operation, and maintenance are the responsibilities of the system designer and user.**

## Warranty Information

Swagelok products are backed by The Swagelok Limited Lifetime Warranty. For a copy, visit your Swagelok Web site or contact your authorized Swagelok representative.

Swagelok, Ferrule-Pak, Goop, Hinging-Colleting, IGC, Kenmac, Micro-Fit, Nupro, Snoop, Sno-Trik, SWAK, VCO, VCR, Ultra-Torr, Whitey—TM Swagelok Company  
Aflas—TM Asahi Glass Co. Ltd.  
AL-6XN—TM Allegheny Ludlum Corporation  
AutoCAD—TM Autodesk, Inc.  
CSA—TM Canadian Standards Association  
DeviceNet—TM ODVA  
Kalrez, Krytox—TM DuPont  
Elgiloy—TM Elgiloy Specialty Metals  
FM—TM FM Global  
Grafoil—TM GrafTech International Holdings, Inc.  
MAC—TM MAC Valves Inc.  
Microsoft, Windows—TM Microsoft Corp.  
NACE—TM NACE International  
Nitronic—TM AK Steel Corporation  
picofast—TM HansTurck KG  
Pillar—TM Nippon Pillar Packing Company, Ltd.  
Rapid Tap—TM Relton Corporation  
15-7 PH, 17-7 PH—TM AK Steel Corp.  
Sandvik—TM SandvikAB  
Silconert—TM Silcotek Corporation  
Simriz—TM Freudenberg-NOK  
SolidWorks—TM SolidWorks Corporation  
© 2017 Swagelok Company