

Filters



FW, F, and TF Series

- Remove system particulate contaminants
- Gas and liquid service
- 1/8 to 1/2 in. and 3 to 12 mm end connections
- Stainless steel and brass materials

Features

All-Welded Inline Filters (FW Series)

- All-welded construction provides reliable fluid containment.
- Inline filters are for use where space is limited.
- Filter is easily cleaned by backflushing.
- Sintered element is available in 0.5 µm nominal pore size; pleated mesh elements are available in 2, 7, and 15 µm nominal pore sizes.
- End connections include Swagelok® tube fittings, NPT, and male VCR® face seal fittings.

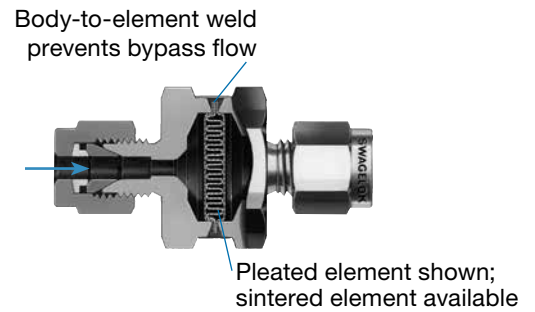

Inline Filters (F Series)

- Inline filters are for use where space is limited.
- Replaceable sintered elements are available in 0.5, 2, 7, 15, 60, and 90 µm nominal pore sizes; replaceable strainer elements are available in 40, 140, 230, and 440 µm nominal pore sizes.
- End connections include Swagelok tube fittings, NPT, tube adapter, and male VCR face seal fittings.

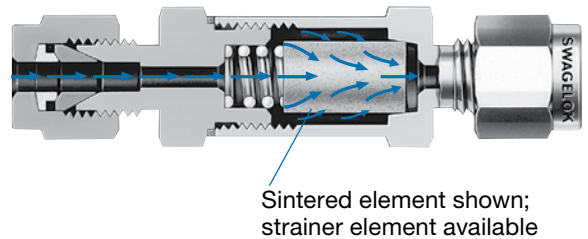

Tee-Type Filters (TF Series)

- Filter element can be replaced without removing body from system.
- Replaceable sintered elements are available in 0.5, 2, 7, 15, 60, and 90 µm nominal pore sizes; replaceable strainer elements are available in 40, 140, 230, and 440 µm nominal pore sizes.
- End connections include Swagelok tube fittings, NPT, and tube socket or tube butt weld ends.
- Select TF series filters are available with ECE R110-type approval for use in alternative fuel service. See **Options and Accessories**, page 8.

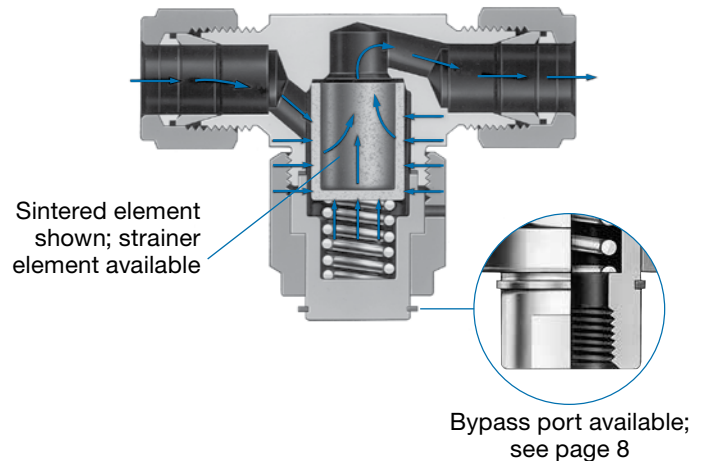

Filter Elements

FW Series

Sintered



- Traps particles as small as 0.5 µm in diameter
- 316L SS construction

Pleated Mesh

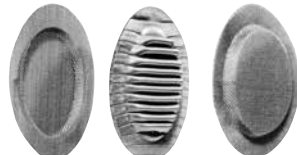

- Retainer screen
- Pleated mesh element
- Retainer screen
- Offers larger filtration area
- Stainless steel construction

F and TF Series

Sintered

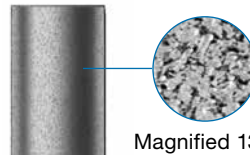

- Traps fine particles in a dense matrix
- 316 SS construction

Strainer

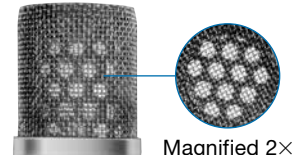

- Removes larger particles
- 316 SS construction

Pressure-Temperature Ratings

Ratings are based on standard materials of construction. Ratings for TF series filters with PCTFE gaskets are limited to 200°F and 3000 psig (93°C and 206 bar). See page 8.

| Filter Series | FW, TF | 2F, 4F | 6F, 8F | F | TF |
|-----------------------|------------------------------|------------|-------------|-------------|------------|
| Material | 316 SS | | | Brass | |
| Temperature, °F (°C) | Working Pressure, psig (bar) | | | | |
| -20 (-28) to 100 (37) | 6000 (413) | 3000 (206) | 2500 (172) | 1000 (68.9) | 2000 (137) |
| 200 (93) | 5160 (355) | 2580 (177) | 2150 (148) | 780 (53.7) | 1730 (119) |
| 300 (148) | 4660 (321) | 2330 (160) | 1940 (133) | 680 (46.8) | 1470 (101) |
| 400 (204) | 4280 (294) | 2140 (147) | 1780 (122) | — | — |
| 500 (260) | 3980 (274) | 1990 (137) | 1660 (114) | — | — |
| 600 (315) | 3760 (259) | 1880 (129) | 1560 (107) | — | — |
| 650 (343) | 3700 (254) | 1845 (127) | 1540 (106) | — | — |
| 700 (371) | 3600 (248) | 1800 (124) | 1500 (103) | — | — |
| 750 (398) | 3520 (242) | 1760 (121) | 1460 (100) | — | — |
| 800 (426) | 3460 (238) | 1725 (118) | 1440 (99.2) | — | — |
| 850 (454) | 3380 (232) | 1690 (116) | 1410 (97.1) | — | — |
| 900 (482) | 3280 (225) | 1640 (112) | 1360 (93.7) | — | — |

Differential Pressure Ratings

| Filter Series | Maximum Differential Pressure psig (bar) | | |
|---------------|---|------------------|-----------------|
| | Sintered Element | Strainer Element | Pleated Element |
| FW | 600 (41.3) | — | 100 (6.8) |
| F, TF | 1000 (68.9) | | — |

Materials of Construction

| Component | Filter Series | Filter Body Materials | |
|-----------------------------------|---------------|---|---|
| | | Brass ^① | 316 SS |
| Material Grade/ASTM Specification | | | |
| Bonnet nut | TF | Brass/B16 | 316 SS/A479 |
| <i>Bonnet</i> | <i>TF</i> | <i>Brass/B16</i> | <i>316 SS/A479</i> |
| Retainer screens (2) | FW | — | 316 SS |
| Element | FW | — | 0.5 µm size— 316L SS 2, 7, and 15 µm size— 316 SS |
| | F, TF | Sintered—316 SS Strainer—316 SS with silver solder | |
| Spring | F, TF | 302 SS | |
| Gasket | F, TF | Aluminum/B209 | Silver-plated 316 SS/A240 |
| Body | All | Brass/B16 | 316 SS/A479 |
| Retaining ring | TF | PH 15-7 Mo [®] SS | |
| Lubricant | F | Silicone-based | |

Wetted components listed in *italics*.

① FW series filters not available in brass.

Filtration Area

| Filter Series | Sintered Element in. ² (mm ²) | Strainer Element in. ² (mm ²) | Pleated Element in. ² (mm ²) |
|------------------|---|---|--|
| FW | 0.44 (283) | — | 2.25 (1450) |
| 2F | 0.55 (350) | — | — |
| 4F, 2TF, 4TF | 1.3 (830) | 1.0 (640) | — |
| 6F, 8F, 6TF, 8TF | 2.0 (1280) | 1.7 (1090) | — |

Flow Data at 70°F (20°C)

FW Series

| End Connections | | Element Nominal Pore Size µm | Inlet Pressure, ^① psig (bar) | | | Pressure Drop, psi (bar) | | |
|--|------------------|---------------------------------------|--|------------|------------|----------------------------------|-------------|-------------|
| | | | 5 (0.34) | 10 (0.68) | 15 (1.0) | 10 (0.68) | 50 (3.4) | 100 (6.8) |
| Inlet/Outlet | Size | | Air Flow, std ft ³ /min (std L/min) | | | Water Flow, U.S. gal/min (L/min) | | |
| Swagelok tube fittings, male VCR fittings | 1/4 in., 6 mm | 0.5 | 0.04 (1.1) | 0.06 (1.7) | 0.12 (3.4) | 0.01 (0.03) | 0.04 (0.15) | 0.12 (0.45) |
| | | 2, 7, 15 | | | | 1.7 (6.4) | 5.5 (20) | 8.3 (31) |
| Female NPT | 1/4 in. | 2, 7, 15 | 5.6 (150) | 10 (280) | 14 (390) | 4.5 (17) | 14 (52) | 18 (68) |
| Male NPT, male/female NPT | 1/4 in. | 2, 7, 15 | | | | 3.5 (13) | 11 (41) | 14 (52) |

^① Outlet is discharged to atmosphere.

F Series

| Element Nominal Pore Size µm | Inlet Pressure, ^① psig (bar) | | | Pressure Drop, psi (bar) | | |
|---------------------------------------|--|------------|------------|----------------------------------|-------------|-------------|
| | 5 (0.34) | 10 (0.68) | 15 (1.0) | 10 (0.68) | 50 (3.4) | 100 (6.8) |
| | Air Flow, std ft ³ /min (std L/min) | | | Water Flow, U.S. gal/min (L/min) | | |
| 2F Series | | | | | | |
| 0.5 | 0.04 (1.1) | 0.06 (1.7) | 0.12 (3.4) | 0.01 (0.03) | 0.04 (0.15) | 0.12 (0.45) |
| 2 | 0.20 (5.6) | 0.40 (11) | 0.60 (17) | 0.08 (0.30) | 0.24 (0.91) | 0.40 (1.5) |
| 7 | 0.50 (14) | 0.90 (25) | 1.2 (34) | 0.10 (0.37) | 0.30 (1.1) | 0.48 (1.8) |
| 15 | 0.80 (22) | 1.3 (36) | 1.5 (42) | 0.12 (0.45) | 0.36 (1.3) | 0.58 (2.1) |
| 60 | 1.7 (48) | 2.2 (62) | 2.4 (68) | 0.15 (0.56) | 0.50 (1.8) | 0.70 (2.6) |
| 90 | 1.8 (51) | 2.2 (62) | 2.6 (73) | 0.20 (0.75) | 0.50 (1.8) | 0.60 (2.2) |
| 4F Series | | | | | | |
| 0.5 | 0.12 (3.4) | 0.26 (7.3) | 0.48 (13) | 0.04 (0.15) | 0.17 (0.64) | 0.29 (1.0) |
| 2 | 0.60 (17) | 1.4 (39) | 2.3 (65) | 0.24 (0.90) | 0.86 (3.2) | 1.3 (4.9) |
| 7 | 1.4 (39) | 2.9 (82) | 4.7 (130) | 0.40 (1.5) | 1.3 (4.9) | 2.0 (7.5) |
| 15 | 1.2 (34) | 2.9 (82) | 4.7 (130) | 0.50 (1.8) | 1.3 (4.9) | 2.1 (7.9) |
| 60 | 3.1 (87) | 5.9 (160) | 8.5 (240) | 0.90 (3.4) | 3.3 (12) | 4.6 (17) |
| 90 | 4.1 (110) | 7.5 (210) | 10 (280) | 1.2 (4.5) | 4.2 (15) | 6.1 (23) |
| 40, 140, 230, 440 | 4.7 (130) | 8.8 (250) | 12 (340) | 1.7 (6.4) | 5.6 (21) | 7.8 (29) |
| 6F and 8F Series | | | | | | |
| 0.5 | 0.36 (10) | 0.86 (24) | 1.6 (45) | 0.09 (0.34) | 0.40 (1.5) | 0.76 (2.8) |
| 2 | 1.4 (39) | 2.8 (79) | 4.0 (110) | 0.26 (0.98) | 1.1 (4.1) | 1.6 (6.0) |
| 7 | 1.8 (51) | 4.2 (119) | 6.8 (190) | 0.64 (2.4) | 2.2 (8.3) | 3.5 (13) |
| 15 | 1.8 (51) | 4.9 (130) | 7.9 (220) | 0.84 (3.1) | 2.6 (9.8) | 4.1 (15) |
| 60 | 5.1 (140) | 10 (280) | 15 (420) | 2.0 (7.5) | 6.7 (25) | 10 (37) |
| 90 | 6.1 (170) | 11 (310) | 16 (450) | 2.3 (8.7) | 7.6 (28) | 11 (41) |
| 40, 140, 230, 440 | 7.2 (200) | 14 (390) | 20 (560) | 4.8 (18) | 15 (56) | 19 (71) |

^① Outlet is discharged to atmosphere.

Flow Data at 70°F (20°C)

TF Series

| Element Nominal Pore Size µm | Inlet Pressure, ^① psig (bar) | | | Pressure Drop, psi (bar) | | |
|---------------------------------------|--|------------|------------|----------------------------------|-------------|------------|
| | 5 (0.34) | 10 (0.68) | 15 (1.0) | 10 (0.68) | 50 (3.4) | 100 (6.8) |
| | Air Flow, std ft ³ /min (std L/min) | | | Water Flow, U.S. gal/min (L/min) | | |
| 2TF Series | | | | | | |
| 0.5 | 0.04 (1.1) | 0.06 (1.7) | 0.12 (3.4) | 0.04 (0.15) | 0.17 (0.64) | 0.29 (1.0) |
| 2 | 0.20 (5.6) | 0.40 (11) | 0.60 (17) | 0.08 (0.30) | 0.24 (0.91) | 0.40 (1.5) |
| 7 | 0.50 (14) | 0.90 (25) | 1.2 (34) | 0.10 (0.37) | 0.30 (1.1) | 0.48 (1.8) |
| 15 | 0.80 (22) | 1.3 (36) | 1.5 (42) | 0.12 (0.45) | 0.36 (1.3) | 0.58 (2.1) |
| 60 | 1.7 (48) | 2.2 (62) | 2.4 (68) | 0.15 (0.56) | 0.50 (1.8) | 0.70 (2.6) |
| 90 | 1.8 (51) | 2.2 (62) | 2.6 (73) | 0.20 (0.75) | 0.50 (1.8) | 0.60 (2.2) |
| 40, 140, 230, 440 | 1.8 (51) | 2.3 (65) | 2.6 (73) | 0.20 (0.75) | 0.50 (1.8) | 0.60 (2.2) |
| 4TF Series | | | | | | |
| 0.5 | 0.12 (3.4) | 0.26 (7.3) | 0.48 (13) | 0.04 (0.15) | 0.17 (0.64) | 0.29 (1.0) |
| 2 | 0.60 (17) | 1.4 (39) | 2.3 (65) | 0.24 (0.90) | 0.86 (3.2) | 1.3 (4.9) |
| 7 | 1.4 (39) | 2.9 (82) | 4.7 (130) | 0.40 (1.5) | 1.3 (4.9) | 2.0 (7.5) |
| 15 | 1.2 (34) | 2.9 (82) | 4.7 (130) | 0.50 (1.8) | 1.3 (4.9) | 2.1 (7.9) |
| 60 | 3.1 (87) | 5.9 (160) | 8.5 (240) | 0.80 (3.0) | 2.7 (10) | 3.9 (14) |
| 90 | 4.1 (110) | 7.5 (210) | 10 (280) | 1.1 (4.1) | 3.4 (12) | 4.9 (18) |
| 40, 140, 230, 440 | 4.7 (130) | 8.8 (250) | 12 (340) | 1.2 (4.5) | 4.2 (15) | 5.6 (21) |
| 6TF and 8TF Series | | | | | | |
| 0.5 | 0.36 (10) | 0.86 (24) | 1.6 (45) | 0.09 (0.34) | 0.40 (1.5) | 0.76 (2.8) |
| 2 | 1.4 (39) | 2.8 (79) | 4.0 (110) | 0.26 (0.98) | 1.1 (4.1) | 1.6 (6.0) |
| 7 | 1.8 (51) | 4.2 (119) | 6.8 (190) | 0.64 (2.4) | 2.2 (8.3) | 3.5 (13) |
| 15 | 1.8 (51) | 4.9 (130) | 7.9 (220) | 0.84 (3.1) | 2.6 (9.8) | 4.1 (15) |
| 60 | 5.1 (140) | 10 (280) | 15 (420) | 1.5 (5.6) | 4.8 (18) | 6.7 (25) |
| 90 | 6.1 (170) | 11 (310) | 16 (450) | 1.7 (6.4) | 5.5 (20) | 7.6 (28) |
| 40, 140, 230, 440 | 7.2 (200) | 14 (390) | 20 (560) | 2.4 (9.0) | 7.2 (27) | 10 (37) |

^① Outlet is discharged to atmosphere.

Testing

Every Swagelok filter is factory tested with nitrogen at 1000 psig (69 bar) to a requirement of no detectable leakage with a liquid leak detector.

Cleaning and Packaging

Swagelok filters with VCR end connections are processed in accordance with Swagelok *Special Cleaning and Packaging (SC-11)* (MS-06-63) to ensure compliance with product cleanliness requirements stated in ASTM G93 Level C.

Swagelok filters with other end connections are processed in accordance with Swagelok *Standard Cleaning and Packaging (SC-10)* (MS-06-62) special cleaning and packaging are available as an option.

Ordering Information and Dimensions

Dimensions are for reference only and are subject to change.

FW Series

Add an element designator to the basic ordering number.

Example: SS-4FWS-05

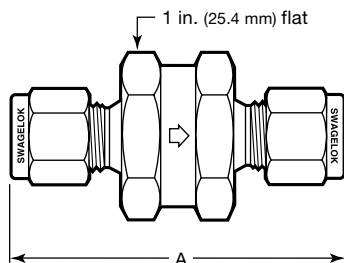

FW Series

| End Connections | | Element Nominal Pore Size μm | Basic Ordering Number | Dimensions, in. (mm) | |
|------------------------|---------|---------------------------------|-----------------------|----------------------|-------------|
| Inlet/Outlet | Size | | | Orifice | A |
| Swagelok tube fittings | 1/4 in. | 0.5 | SS-4FWS- | 0.187 (4.75) | 2.09 (53.1) |
| | 1/4 in. | 2, 7, 15 | SS-4FW- | | 2.15 (54.6) |
| | 6 mm | 0.5 | SS-6FWS-MM- | | 2.13 (54.1) |
| | 6 mm | 2, 7, 15 | SS-6FW-MM- | | 2.15 (54.6) |
| Female NPT | 1/4 in. | 2, 7, 15 | SS-4FW4- | 0.453 (11.5) | 1.57 (39.9) |
| Male NPT | 1/4 in. | | SS-4FW2- | 0.281 (7.14) | 1.89 (48.0) |
| Male/female NPT | 1/4 in. | | SS-4FW5- | 0.281 (7.14) | 1.72 (43.7) |
| Male VCR fittings | 1/4 in. | 0.5 | SS-4FWS-VCR- | 0.187 (4.75) | 2.00 (50.8) |
| | 1/4 in. | 2, 7, 15 | SS-4FW-VCR- | | 2.04 (51.8) |

Dimensions shown with Swagelok tube fitting nuts finger-tight.

FW Series Elements

Elements remove 95 % of particles larger than the nominal pore size.

| Nominal Pore Size μm | Pore Size Range μm | Element Type | Element Designator |
|-------------------------|-----------------------|--------------|--------------------|
| 0.5 | 0.5 to 2 | Sintered | 05 |
| 2 | — | Pleated | 2 |
| 7 | — | | 7 |
| 15 | — | | 15 |

F Series and TF Series

Stainless Steel Filters

Add an element designator to the basic ordering number.

Example: SS-2F-2

Brass Filters

Replace **SS** with **B** in the ordering number.

Example: B-2F-2

Filters with VCR fitting end connections are not available in brass.

F and TF Series Elements

Elements remove 95 % of particles larger than the nominal pore size.

| Nominal Pore Size μm | Pore Size Range μm | Element Type | Element Designator |
|-------------------------|-----------------------|--------------|--------------------|
| 0.5 | 0.5 to 2 | Sintered | 05 |
| 2 | 1 to 4 | | 2 |
| 7 | 5 to 10 | | 7 |
| 15 | 11 to 25 | | 15 |
| 40 ^① | — | Strainer | 40 |
| 60 | 50 to 75 | Sintered | 60 |
| 90 | 75 to 100 | | 90 |
| 140 ^① | — | Strainer | 140 |
| 230 ^① | — | | 230 |
| 440 ^① | — | | 440 |

^① Not available for 2F series.

Ordering Information and Dimensions

F Series

| End Connections | | Basic Ordering Number | Filter Series | Dimensions, in. (mm) | | |
|--|---------|-----------------------|---------------|----------------------|-------------|-------------|
| Inlet/Outlet | Size | | | Orifice | A | B |
| Swagelok tube fittings | 1/8 in. | SS-2F- | 2F | 0.094 (2.39) | 2.35 (59.7) | 9/16 (14.3) |
| | 1/4 in. | SS-4F- | 4F | 0.187 (4.75) | 2.95 (74.9) | 3/4 (19.0) |
| | 3/8 in. | SS-6F- | 6F | 0.281 (7.14) | 3.21 (81.5) | 1 (25.4) |
| | 1/2 in. | SS-8F- | 8F | 0.406 (10.3) | 3.49 (88.6) | |
| | 3 mm | SS-3F-MM- | 2F | 0.094 (2.39) | 2.38 (60.5) | 9/16 (14.3) |
| | 6 mm | SS-6F-MM- | 4F | 0.187 (4.75) | 2.96 (75.2) | 3/4 (19.0) |
| Female NPT | 1/8 in. | SS-2F4- | 2F | 0.094 (2.39) | 2.16 (54.9) | 9/16 (14.3) |
| | 1/4 in. | SS-4F4- | 4F | 0.187 (4.75) | 2.87 (72.9) | 3/4 (19.0) |
| Male NPT | 1/4 in. | SS-4F2- | 4F | | 2.69 (68.3) | |
| Male VCR fittings | 1/4 in. | SS-4F-VCR- | 4F | | 2.82 (71.6) | |
| Swagelok tube fitting/ tube adapter | 1/8 in. | SS-2F-T7- | 2F | 0.094 (2.39) | 2.29 (58.2) | 9/16 (14.3) |
| | 1/4 in. | SS-4F-T7- | 4F | 0.187 (4.75) | 2.91 (73.9) | 3/4 (19.0) |

Dimensions shown with Swagelok tube fitting nuts finger-tight.

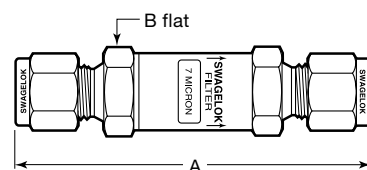

TF Series

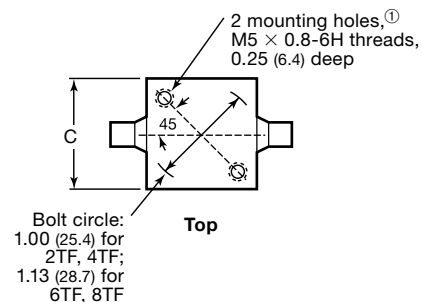
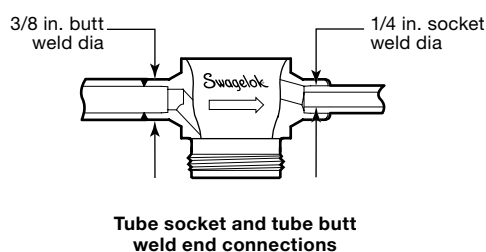
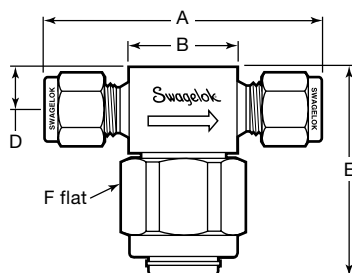

| End Connections | | Basic Ordering Number | Filter Series | Dimensions, in. (mm) | | | | | | |
|-------------------------------------|-----------------|-----------------------|---------------|----------------------|-------------|-------------|-------------|-------------|-------------|--------------|
| Type | Size | | | Orifice | A | B | C | D | E | F |
| Swagelok tube fitting | 1/8 in. | SS-2TF- | 2TF | 0.094 (2.39) | 2.27 (57.7) | 1.07 (27.2) | 1.00 (25.4) | 0.38 (9.7) | 1.87 (47.5) | 1 (25.4) |
| | 1/4 in. | SS-4TF- | 4TF | 0.174 (4.41) | 2.47 (62.7) | 1.06 (26.9) | | | | |
| | 3/8 in. | SS-6TF- | 6TF | 0.213 (5.41) | 2.84 (72.1) | 1.32 (33.5) | 1.13 (28.7) | 0.46 (11.7) | 2.20 (55.9) | 1 1/8 (28.6) |
| | 1/2 in. | SS-8TF- | 8TF | 0.250 (6.35) | 3.04 (77.2) | 1.31 (33.3) | | | | |
| | 6 mm | SS-6TF-MM- | 4TF | 0.172 (4.36) | 2.46 (62.5) | 1.06 (26.9) | 1.00 (25.4) | 0.38 (9.7) | 1.87 (47.5) | 1 (25.4) |
| | 8 mm | SS-8TF-MM- | 6TF | 0.213 (5.41) | 2.84 (72.1) | 1.38 (35.1) | | | | |
| | 10 mm | SS-10TF-MM- | 8TF | 0.250 (6.35) | 2.86 (72.6) | 1.32 (33.5) | 1.13 (28.7) | 0.46 (11.7) | 2.20 (55.9) | 1 1/8 (28.6) |
| 12 mm | SS-12TF-MM- | 8TF | 3.04 (77.2) | | 1.31 (33.3) | | | | | |
| Female NPT | 1/8 in. | SS-2TF4- | 2TF | 0.174 (4.41) | 2.00 (50.8) | 1.00 (25.4) | 1.00 (25.4) | 0.38 (9.7) | 1.87 (47.5) | 1 (25.4) |
| | 1/4 in. | SS-4TF4- | 4TF | | 2.13 (54.1) | | | | | |
| Male NPT | 1/4 in. | SS-4TF2- | 4TF | 0.174 (4.41) | 2.13 (54.1) | 1.00 (25.4) | 1.00 (25.4) | 0.38 (9.7) | 1.87 (47.5) | 1 (25.4) |
| | 3/8 in. | SS-6TF2- | 6TF | 0.250 (6.35) | 2.38 (60.5) | 1.25 (31.8) | 1.13 (28.7) | 0.46 (11.7) | 2.20 (55.9) | 1 1/8 (28.6) |
| | 1/2 in. | SS-8TF2- | 8TF | | 2.75 (69.9) | | | | | |
| Tube socket weld and tube butt weld | 1/4 and 3/8 in. | SS-4TF-TW- | 4TF | 0.174 (4.41) | 1.68 (42.7) | 1.00 (25.4) | 1.00 (25.4) | 0.38 (9.7) | 1.87 (47.5) | 1 (25.4) |

Dimensions shown with Swagelok nuts finger-tight.

① Mounting holes not available with 1/4 in. female NPT end connections.

Options and Accessories

All Filters

Special Cleaning and Packaging (SC-11)

Swagelok filters with VCR end connections are processed in accordance with Swagelok *Special Cleaning and Packaging (SC-11)* (MS-06-63) to ensure compliance with product cleanliness requirements stated in ASTM G93 Level C.

To order special cleaning and packaging for filters with other end connections, add **-SC11** to the valve ordering number.

Example: SS-4FWS-40-**SC11**

F and TF Series

Element Kits

Kits include element and instructions.

Select a basic kit ordering number and add an element designator.

Example:
SS-2F-K4-05

| Filter Series ^① | Basic Kit Ordering Number |
|----------------------------|---------------------------|
| 2F | SS-2F-K4- |
| 4F, 2TF, 4TF | SS-4F-K4- |
| 6F, 8F, 6TF, 8TF | SS-8F-K4- |

^① See **Dimensions** tables, page 7, for filter series information.

| Nominal Pore Size μm | Pore Size Range μm | Element Type | Element Designator |
|---------------------------------|-------------------------------|--------------|--------------------|
| 0.5 | 0.5 to 2 | Sintered | 05 |
| 2 | 1 to 4 | | 2 |
| 7 | 5 to 10 | | 7 |
| 15 | 11 to 25 | | 15 |
| 40 ^① | — | Strainer | 40 |
| 60 | 50 to 75 | Sintered | 60 |
| 90 | 75 to 100 | | 90 |
| 140 ^① | — | Strainer | 140 |
| 230 ^① | — | | 230 |
| 440 ^① | — | | 440 |

^① Not available for 2F series.

Gasket Kits

Kits include gasket and instructions. To order a stainless steel gasket kit, select a kit ordering number. For other gasket materials, replace **SS** with **A** for aluminum or **KF** for PCTFE (TF series only).

Example: **A-2F-K3**

| Filter Series ^① | Kit Ordering Number |
|----------------------------|---------------------|
| 2F | SS-2F-K3 |
| 4F | SS-4F-K3 |
| 6F, 8F | SS-8F-K3 |
| 2TF, 4TF | SS-4TF-K2 |
| 6TF, 8TF | SS-8TF-K2 |

^① See **Dimensions** tables, page 7, for filter series information.

F Series

Special Alloys

Filters of alloy C-276 are available in some sizes. Contact your authorized Swagelok sales and service representative for more information.

TF Series

Bypass Port

The bypass port at the filter bottom enables sampling or purging. To order, insert a designator into the filter ordering number.

Example:
SS-2TF-**F1**-05

| Filter Series | Bypass Port End Connection | Designator | Overall Height in. (mm) |
|---------------|-------------------------------|------------|-------------------------|
| 2TF, 4TF | 1/8 in. Swagelok tube fitting | -F1 | 2.36 (59.9) |
| | 1/8 in. female NPT | -F2 | 2.09 (53.1) |
| | 1/4 in. Swagelok tube fitting | -F3 | 2.82 (71.6) |
| | 1/4 in. tube socket weld | -F8 | 2.21 (56.1) |
| 6TF, 8TF | 1/8 in. female NPT | -F4 | 2.46 (62.5) |
| | 1/4 in. Swagelok tube fitting | -F5 | 3.14 (79.8) |
| | 3/8 in. Swagelok tube fitting | -F6 | 3.20 (81.3) |
| | 1/2 in. Swagelok tube fitting | -F7 | 3.42 (86.9) |

Filters Without Elements

TF series filters can be ordered without elements. Add **LE** to the basic ordering number.

Example: SS-2TF-**LE**

Filters With ECE R110-Type Approval

Stainless steel TF series filters with stainless steel sintered or strainer elements are available tested with ECE R110-type approval for use in alternative fuel service.

- Temperature rating: -40 to 248°F (-40 to 120°C)
- Pressure rating within the range: 3770 psig (260 bar)

To order, add **-12463** to a standard TF series filter ordering number.

Example: SS-2TF-05-**12463**

Oxygen Service Hazards

For more information about hazards and risks of oxygen-enriched systems, see the Swagelok *Oxygen System Safety* technical report (MS-06-13).

Caution: Do not mix or interchange parts with those of other manufacturers.

About this document

Thank you for downloading this electronic catalog, which is part of General Product catalog Swagelok published in print. This type of electronic catalog is updated as new information arises or revisions, which may be more current than the printed version.

Swagelok Company is a major developer and provider of fluid system solutions, including products, integration solutions and services for industry research, instrumentation, pharmaceutical, oil and gas, power, petrochemical, alternative fuels, and semiconductor. Our manufacturing facilities, research, service and distribution facilities support a global network of more than 200 authorized sales and service centers in 57 countries.

Visit www.swagelok.com to locate your Swagelok representative and obtain any information on features, technical information and product references, or to learn about the variety of services available only through authorized sales centers and service Swagelok.

Safe Product Selection

When selecting a product, the total system design must be considered to ensure safe, trouble-free performance. Function, material compatibility, adequate ratings, proper installation, operation, and maintenance are the responsibilities of the system designer and user.

Warranty Information

Swagelok products are backed by The Swagelok Limited Lifetime Warranty. For a copy, visit your Swagelok Web site or contact your authorized Swagelok representative.

Swagelok, Ferrule-Pak, Goop, Hinging-Colleting, IGC, Kenmac, Micro-Fit, Nupro, Snoop, Sno-Trik, SWAK, VCO, VCR, Ultra-Torr, Whitey—TM Swagelok Company
Aflas—TM Asahi Glass Co. Ltd.
AL-6XN—TM Allegheny Ludlum Corporation
AutoCAD—TM Autodesk, Inc.
CSA—TM Canadian Standards Association
DeviceNet—TM ODVA
Kalrez, Krytox—TM DuPont
Elgiloy—TM Elgiloy Specialty Metals
FM—TM FM Global
Grafoil—TM GrafTech International Holdings, Inc.
MAC—TM MAC Valves Inc.
Microsoft, Windows—TM Microsoft Corp.
NACE—TM NACE International
Nitronic—TM AK Steel Corporation
picofast—TM HansTurck KG
Pillar—TM Nippon Pillar Packing Company, Ltd.
Rapid Tap—TM Relton Corporation
15-7 PH, 17-7 PH—TM AK Steel Corp.
Sandvik—TM SandvikAB
Silconert—TM Silcotek Corporation
Simriz—TM Freudenberg-NOK
SolidWorks—TM SolidWorks Corporation
© 2017 Swagelok Company