

PFA Plug Valves

43 Series

Features

- Quarter-turn operation and full flow design.
- Light in weight.
- High-purity PFA material with low extractables for chemical resistance.
- 1/4 in. Swagelok® PFA tube fitting end connections for consistent performance.

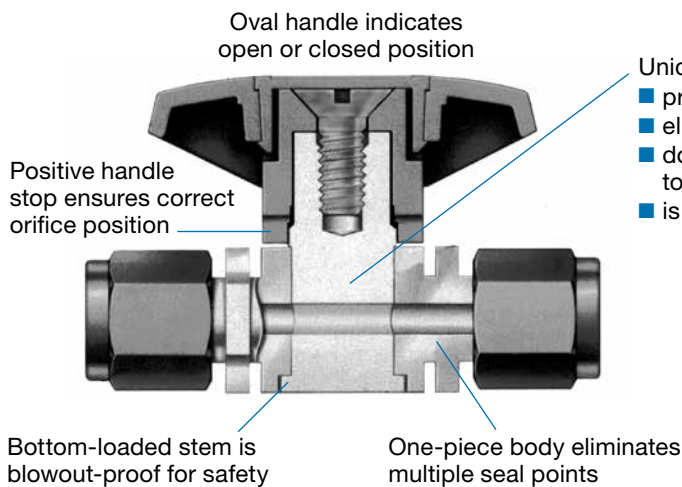

Materials of Construction

Component	Material Grade/ ASTM Specification
1 Handle insert ^①	PFA 440-HP
2 Screw ^①	
3 Handle ^①	
4 Body, ferrules ^①	<i>Virgin PFA 440-HP/ D3307</i>
5 Nut ^①	PFA 440-HP
6 Stem	<i>Virgin PTFE/ D1710</i>
Lubricant	PTFE-based



Wetted components listed in *italics*.

① Blue dyed.

Technical Data

Ordering Number	Orifice in. (mm)	C _v	Pressure Rating at 70°F (20°C)
PFA-43S4	0.156 (4.0)	1.8	60 psig (4.1 bar)

Pressure-Temperature Ratings

Temperature °F (°C)	Liquid Service	Gas Service
	Working Pressure, psig (bar)	
0 (-17) to 50 (10)	60 (4.1)	—
50 (10) to 70 (20)	60 (4.1)	60 (4.1)
100 (37)	50 (3.4)	50 (3.4)
150 (65)	30 (2.0)	30 (2.0)
200 (93)	10 (0.68)	—

Operation in a stable temperature environment will maximize valve life and performance.

Flow Data at 70°F (20°C)

Pressure Drop to Atmosphere (Δp) psi (bar)	Air Flow std ft ³ /min (std L/min)	Water Flow U.S. gal/min (L/min)
10 (0.68)	20 (566)	5.7 (21.5)
30 (2.0)	37 (1047)	9.9 (37.4)
60 (4.1)	62 (1755)	14.0 (52.9)

Testing

Every 43 series PFA plug valve is factory tested with nitrogen at two times the rated pressure for leakage at the seat to a maximum allowable leak rate of 0.1 std cm³/min. Body seals are tested with helium at two times the rated pressure to a maximum allowable leak rate of 1 × 10⁻³ std cm³/s.

Cleaning and Packaging

Every 43 series PFA plug valve is cleaned and packaged in accordance with Swagelok *Standard Cleaning and Packaging (SC-10)* (MS-06-62).

Dimensions

Dimensions, in inches (millimeters), are for reference only and are subject to change.

Ordering Number: PFA-43S4

Weight: 0.13 lb (0.06 kg)

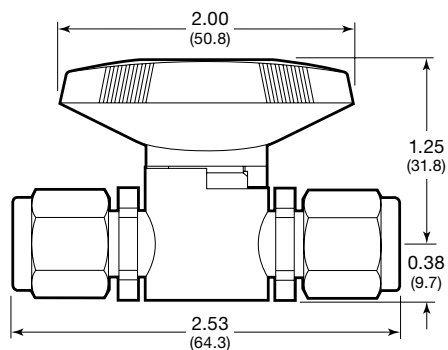

Dimensions shown with Swagelok nuts positioned prior to swaging.

Accessories

Panel Mount Bracket

316 stainless steel bracket enables back or front mounting.

To order a Swagelok PFA plug valve with back mount assembly, add **-PM** to the ordering number.

Example: PFA-43S4-PM

To order a field assembly kit with mounting bracket and instructions, use ordering number SS-MB-P43.

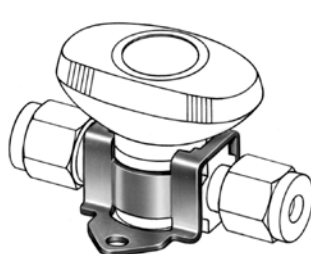

Back Mount Assembly

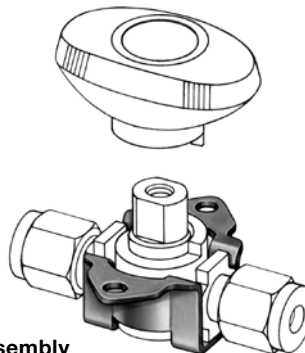

Front Mount Assembly

Combined panel thickness and screw head height above panel must not exceed 1/4 in. (6.4 mm).

Panel Hole Drill Dimensions

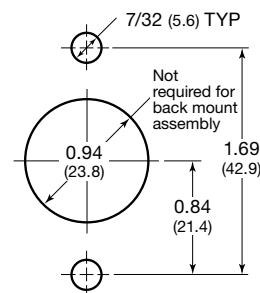

Other Swagelok PFA Products

For more information about Swagelok PFA tubing and tools, see the Swagelok *Hose and Flexible Tubing* catalog (MS-01-180).

For more information about Swagelok PFA tube fittings, see the Swagelok *PFA Tube Fittings* catalog (MS-01-05).

For more information about Swagelok PFA needle valves, see the Swagelok *PFA Needle Valves* catalog (MS-01-69).



Installation Instructions

⚠ PFA tubing MUST be grooved for use with PFA tube fittings. Use the Swagelok groove cutter tool.

1. Insert grooved PFA tubing into the Swagelok PFA tube fitting until a clicking sound is heard.
2. While holding fitting body steady, tighten the blue nut until there is no gap between the nut and body hexes.
3. Continue tightening until the nut and body hexes are aligned.

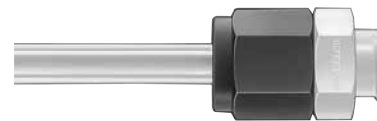
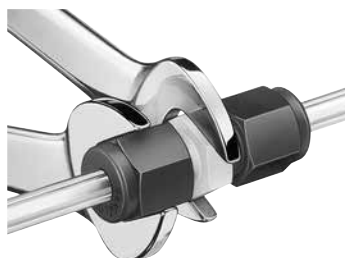
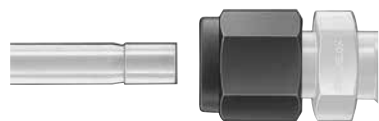

Caution: Do not mix or interchange parts with those of other manufacturers.

About this document

Thank you for downloading this electronic catalog, which is part of General Product catalog Swagelok published in print. This type of electronic catalog is updated as new information arises or revisions, which may be more current than the printed version.

Swagelok Company is a major developer and provider of fluid system solutions, including products, integration solutions and services for industry research, instrumentation, pharmaceutical, oil and gas, power, petrochemical, alternative fuels, and semiconductor. Our manufacturing facilities, research, service and distribution facilities support a global network of more than 200 authorized sales and service centers in 57 countries.

Visit www.swagelok.com to locate your Swagelok representative and obtain any information on features, technical information and product references, or to learn about the variety of services available only through authorized sales centers and service Swagelok.

Safe Product Selection

When selecting a product, the total system design must be considered to ensure safe, trouble-free performance. Function, material compatibility, adequate ratings, proper installation, operation, and maintenance are the responsibilities of the system designer and user.

Warranty Information

Swagelok products are backed by The Swagelok Limited Lifetime Warranty. For a copy, visit your Swagelok Web site or contact your authorized Swagelok representative.

Swagelok, Ferrule-Pak, Goop, Hinging-Colleting, IGC, Kenmac, Micro-Fit, Nupro, Snoop, Sno-Trik, SWAK, VCO, VCR, Ultra-Torr, Whitey—TM Swagelok Company
Aflas—TM Asahi Glass Co. Ltd.
AL-6XN—TM Allegheny Ludlum Corporation
AutoCAD—TM Autodesk, Inc.
CSA—TM Canadian Standards Association
DeviceNet—TM ODVA
Kalrez, Krytox—TM DuPont
Elgiloy—TM Elgiloy Specialty Metals
FM—TM FM Global
Grafoil—TM GrafTech International Holdings, Inc.
MAC—TM MAC Valves Inc.
Microsoft, Windows—TM Microsoft Corp.
NACE—TM NACE International
Nitronic—TM AK Steel Corporation
picofast—TM HansTurck KG
Pillar—TM Nippon Pillar Packing Company, Ltd.
Rapid Tap—TM Relton Corporation
15-7 PH, 17-7 PH—TM AK Steel Corp.
Sandvik—TM SandvikAB
Silconert—TM Silcotek Corporation
Simriz—TM Freudenberg-NOK
SolidWorks—TM SolidWorks Corporation
© 2017 Swagelok Company