

Montréal, 4 février 2026.

TANYA FRANCIS
TECHNICAL STANDARDS & SAFETY AUTHORITY
345 CARLINGVIEW DRIVE
TORONTO ONTARIO
CANADA M9W 6N9

Fabricant : SWAGELOK COMPANY
29500 SOLON ROAD
SOLON OHIO
U.S.A. 44139

Numéro de dossier : 940902

Numéro(s) de dessin(s) : Attachment A (Manufacturing Locations)&AttachmentB
Dated 10-03-2025/ 0C26278.5

Objet : Enregistrement des plans et devis – Confirmation de l'enregistrement

Bonjour,

Nous vous informons que votre demande d'enregistrement de plans et devis a été traitée et que cette conception a été enregistrée sous le numéro d'enregistrement canadien (NEC\CRN) suivant : **0C26278.56**.

Nous portons votre attention sur certaines exigences réglementaires concernant les installations sous pression, ainsi que des codes et normes qui y sont associés :

- Le fabricant doit maintenir un programme de contrôle de la qualité valide pour fabriquer un équipement selon ce NEC;
- Ce numéro d'enregistrement demeure valide tant et aussi longtemps que les paramètres de conception demeurent inchangés. Dans le cas d'accessoires, l'enregistrement est valide pour une durée de 10 ans à partir de la date d'enregistrement. Les documents de conception doivent alors être resoumis pour validation;
- Le fabricant doit nous transmettre une copie de la *Déclaration de conformité du constructeur (Manufacturer's Data Report)* pour chaque appareil ou chaudière fabriqué selon ce NEC dans les 30 jours suivant la signature de cette déclaration;
- Le numéro de dessin enregistré et le numéro de révision doivent être indiqués sur la déclaration de conformité pour les équipements fabriqués selon ce NEC.

Le présent avis d'approbation ne dégage pas le fabricant de ses responsabilités quant à la conception ou à la construction des équipements ou d'accessoires fabriqués selon un NEC.

Salutations distinguées,

Direction des équipements sous pression

Montréal

255, boul. Crémazie Est, 2^{ième} étage

Montréal (Québec) H2M 1L5

Téléphone : 514 873-2546

Sans frais : 1 866 262-2084

enregistrementdesplans@rbq.gouv.qc.ca

www.rbq.gouv.qc.ca

Montréal, le 4 février 2026.

TANYA FRANCIS
TECHNICAL STANDARDS & SAFETY AUTHORITY
345 CARLINGVIEW DRIVE
TORONTO ONTARIO
CANADA M9W 6N9

Manufacturer : SWAGELOK COMPANY
29500 SOLON ROAD
SOLON OHIO
U.S.A. 44139

OUR REFERENCE : 940902

Design number : Attachment A (Manufacturing Locations)&AttachmentB
Dated 10-03-2025/ 0C26278.5

Subject: Design registration confirmation

Hi,

We wish to inform you that your design registration application has been evaluated and that it was registered under the following Canadian Registration Number (CRN): **0C26278.56**.

The following is a reminder of your obligations regarding certain requirements of the regulation respecting pressure vessels, and the referenced codes and standards:

- The manufacturer must maintain a valid quality control program to manufacture equipment according to the CRN.
- The CRN remains valid as long as there are no changes to the design calculations that might affect the pressure boundary. The design registration of fittings expires 10 years after acceptance. It must, therefore, be resubmitted for validation.
- The manufacturer shall submit a copy of the *Manufacturer's Data Report* to us for each boiler or pressure vessel manufactured according to this CRN within 30 days following the signing of this report.
- The drawing number and the revision number registered under this CRN must be indicated on the *Manufacturer's Data Report* for equipment manufactured according to the CRN.

This notice of approval does not relieve the manufacturer of their responsibilities with respect to the design or fabrication of equipment manufactured according to this CRN.

Yours sincerely,

Direction des équipements sous pression

Montréal

255, boul. Crémazie Est, 2ième étage
Montréal (Québec) H2M 1L5
Téléphone : 514 873-2546
Sans frais : 1 866 262-2084
enregistrementdesplans@rbq.gouv.qc.ca
www.rbq.gouv.qc.ca

Attachment B: Scope of CRN Registration for Swagelok Diaphragm, DL & DS Series Valves (Category C)

Product Scope

This document represents the scope of Diaphragm, DL / DS Series Valves covered by this submission for CRN approval. These Diaphragm, DL / DS Series Valves have been evaluated in accordance with ASME B31.1 and B31.3 for unlisted components.

Table 1 – Summary Table

Product Series	Main Pressure Bearing Component	Main Pressure Bearing Material	Port Connections and Sizes	Maximum Allowable Working Pressure		Design Code of Construction
				@100°F	At Max. Temp.	
DS (*see below)	Body, Bonnet Nut, Bonnet	316LV SS (ASTM A479)	Tube Butt Welds 1/4", 3/8" Tube Socket & Tube Butt Welds 1/4" & 3/8", 3/8" & 1/2" Swagelok Tube Fittings 1/4",	3500 psig	2800 psig@250°F	ASME B31.1 (Unlisted Components) and ASME B31.3 (Unlisted Components)
		316/316L SS Dual Certified (ASTM A479)	3/8", 6 mm, 8 mm Female VCR 1/4" Female to Male VCR 1/4" Male to Female VCR 1/4"	3500 psig		
		316/316L SS Dual Certified (ASTM A479)	VCO O-Ring Fitting 1/4" Male VCR Fitting 1/4"	3500 psig		
DL (*see below)	Body, Bonnet Nut, Bonnet	316LV SS (ASTM A479)	Tube Butt Welds 1/4", 3/8" Tube Socket & Tube Butt Welds 1/4" & 3/8", 3/8" & 1/2" Swagelok Tube Fittings 1/4",	3500 psig	2800 psig@250°F	ASME B31.1 (Unlisted Components) and ASME B31.3 (Unlisted Components)
		316/316L SS Dual Certified (ASTM A479)	3/8", 6 mm, 8 mm Female VCR 1/4" Female to Male VCR 1/4" Male to Female VCR 1/4"	3500 psig		
		316/316L SS Dual Certified (ASTM A479)	VCO O-Ring Fitting 1/4" Male VCR Fitting 1/4"	3500 psig		

* Mode of operation: hand operated and hand actuated (all materials).

Product Description

All DS/DL Series Diaphragm Valves have the same features as shown below.

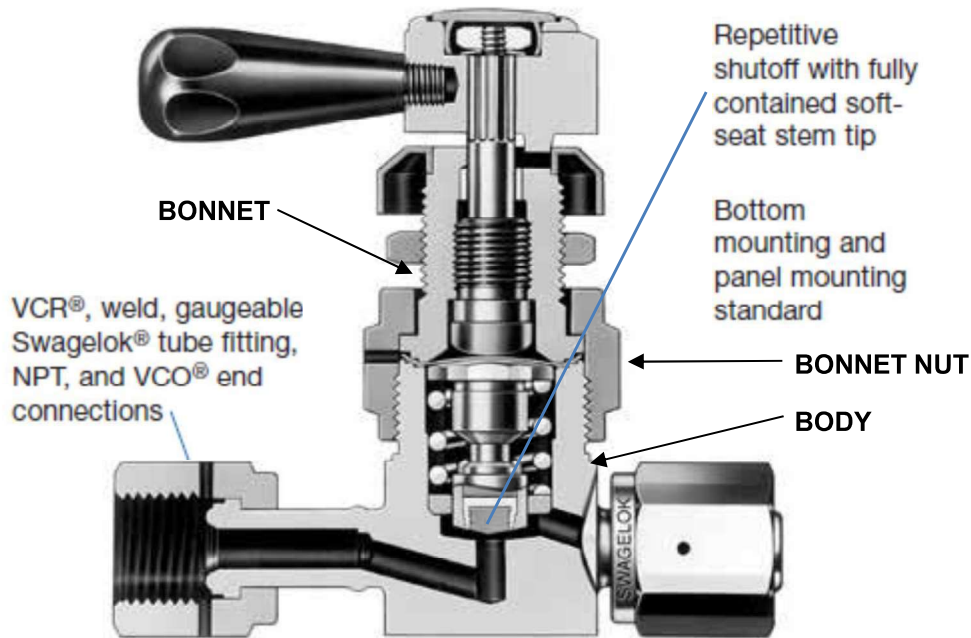

Configurations

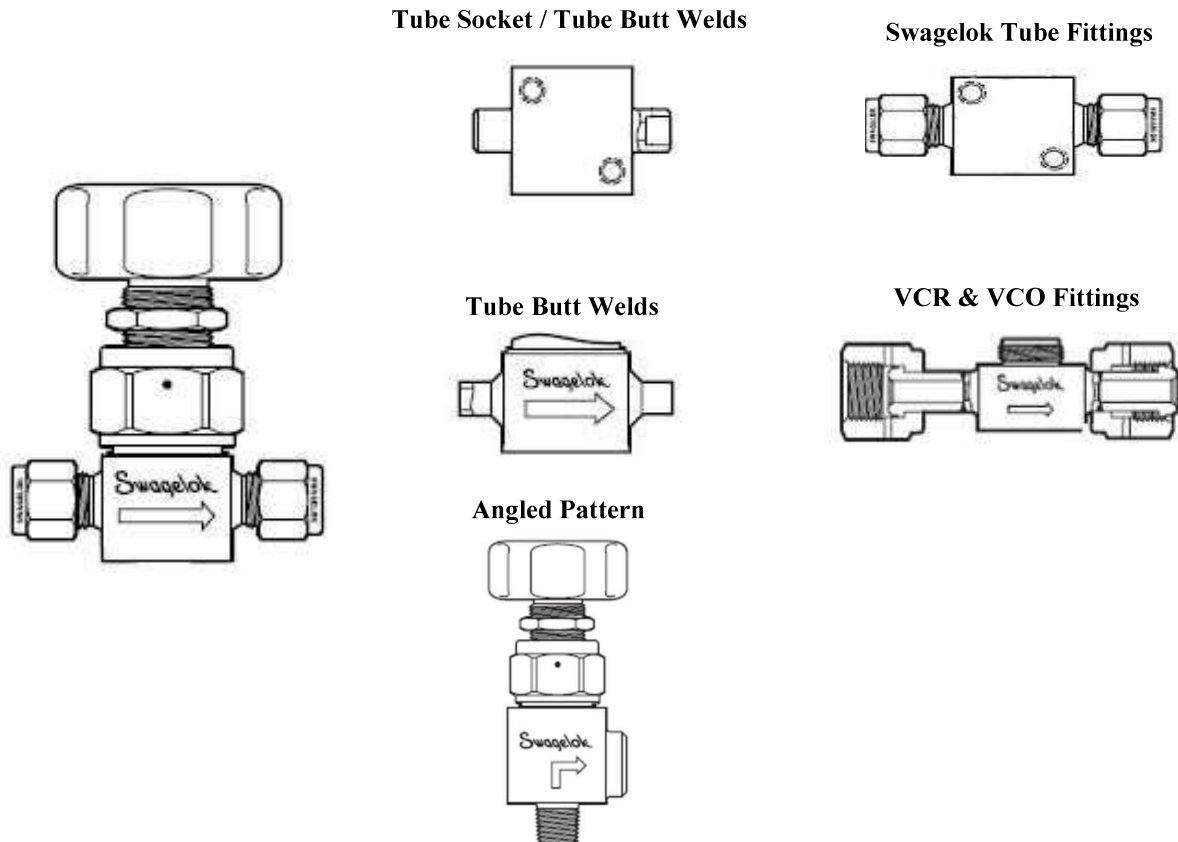



Product Options:

Additional options and non-pressure boundary alterations that do not affect pressure-temperature ratings may be made available within the scope of this registration. Examples of these would include, but not be limited to, handle options, indicators, actuators, stem tips, etc.

Quality System

The Swagelok Company quality system complies with the requirements of ISO 9001:2015. The Swagelok Company maintains British Standards Institution Certificate of Registration Number FM 01729, which applies to all locations listed on the Certificate.

References

The product catalog does not represent the full scope of the registration but rather details some of the most common options.

- Diaphragm Valves, DS and DL Series Catalog – MS-01-73, Rev. O

Attachment A. Swagelok Manufacturing Locations

This document lists the Swagelok locations where end item or component level manufacturing activities take place.



Swagelok Company 29500 Solon Road Solon, Ohio 44139 USA	Swagelok Company (HPF) 6050 Cochran Road Solon, Ohio 44139 USA
Swagelok Company (OFC) 29495 F.A. Lennon Drive Solon, Ohio 44139 USA	Swagelok Company (Snow Metal) 6060 Cochran Road Solon, Ohio 44139 USA
Swagelok Precision Machining Services 1924 East 337th Street Eastlake, OH 44095 USA	Swagelok (China) Fluid System Technologies Ltd. Changshu Export Process Zone Changshu Economic Development Zone Changshu, Jiangshu 215513 China
Swagelok Company (Highland) 318 Bishop Road Highland Heights, Ohio 44143 USA	Swagelok Company (Strongsville) 15400 Foltz Road Strongsville, Ohio 44119
Swagelok Company (Atlantic) 26651 Curtiss Wright Parkway Willoughby Hills, Ohio 44092 USA	Swagelok Company (Alfred) 29500 Ambina Drive Solon, Ohio 44139
Swagelok Company (Micro) 26653 Curtiss Wright Parkway Willoughby Hills, Ohio 44092 USA	Swagelok Hose Services Company (SHSC) 29900 Solon Industrial Parkway Solon, Ohio 44139
Swagelok Company (Falon 1) 348 Bishop Road Highland Heights, Ohio 44143 USA	Swagelok Limited Ballafletcher Road Tromode IM4 4RA Isle of Man
Swagelok Company (Falon 2) 358 Bishop Road Highland Heights, Ohio 44143 USA	Swagelok Company (Valley City) 5370 Wegman Drive Valley City, Ohio 44280 USA



Technical Standards and Safety Authority
 345 Carlingview Drive
 Toronto, Ontario M9W 6N9
 www.tssa.org

Show facsimile of manufacturer's logo or trademark, as it will appear on the fitting, in the space below



STATUTORY DECLARATION Registration of Fittings

I, James Nordholt, Vice President of Engineering
(Name and Position, e.g. President, Plant Manager, Chief Engineer)

of Swagelok Company
(Name of Manufacturer)

Located at 29500 Solon Road, Solon, Ohio 44139 USA (440) 248-4600 (440) 349-5970
(Plant Address) (Telephone No.) (Fax No.)

do solemnly declare that the fittings listed hereunder, which are subject to the **Technical Standards and Safety Act**, Boilers and Pressure Vessels Regulation, comply with all of the requirements of ASME B31.1 for unlisted components, and ASME B31.3 for unlisted components
(Title of recognized North American Standard)

which specifies the dimensions, materials of construction, pressure/temperature ratings, identification marking the fittings and service;

or are not covered by the provisions of a recognized North American standard and are therefore manufactured to comply with _____ as supported by the attached data which identifies the dimensions, material of construction, pressure/temperature ratings and the basis for such ratings, the marking of the fitting for identification and service.

I further declare that the manufacture of these fittings is controlled by a quality system meeting the requirements of ISO 9001:2015 which has been verified by the following authority, BSI

The items covered by this declaration, for which I seek registration, are category C type fittings. In support of this application, the following information and/or test data are attached as follows:
ISO:2015 Certificate, Attachment A, Attachment B, Catalog MS-01-73, and other Support Documents
(drawings, calculations, test reports, etc.)

Declared before me at SOLON in the STATE of OHIO

the 20 day of OCTOBER AD 2025

Commissioner for Oaths:

JEFFREY C TRUMBULL
(Printed name)

[Signature]
(Signature)



JEFFREY C TRUMBULL
 Notary Public
 State of Ohio
 My Comm. Expires
 April 15, 2030

[Signature]
(Signature of Declarer)

FOR OFFICE USE ONLY

To the best of my knowledge and belief, the application meets the requirements of the **Technical Standards and Safety Act**, Boilers and Pressure Vessels Regulation, and CSA Standard B51 and is accepted for registration in Category _____.

CRN: _____

Registered by: _____

Dated: _____

NOTE: This registration expires on: _____



*Information provided in this application is releasable under the Freedom of Information and Privacy Protection Act and may be disclosed upon request.