

TF72

Tube Facing Tool



This manual contains important information for the safe and effective operation of the Swagelok® TF72 series tube facing tool. Users should read and understand its contents before operating the tube facing tool.

Contents

- Safety5**
 - Safety Summary5
 - Environmental Protection/Disposal7
- Product Information8**
 - Accessories9
- Specifications10**
 - Application range.10
 - Tube materials10
 - Technical data10
- Setup11**
 - Description11
 - Unpacking the Tube Facing Tool12
 - Installation of the Cutting Insert and the Tool Holder . . .12
 - Installing the Collet Set.13
 - Removing the Collet Set13
- Operation14**
 - Adjusting for Tube Size.14
 - Clamping the tube15
 - Removing the Tube.15
 - Tool Speed Range15
 - Facing the Tube16
- Maintenance18**
- Troubleshooting19**

Safety

Safety Summary



Read the entire safety information section and Tube Facing Tool User's Manual before using this product. Failure to do so can result in serious injury or death.

Signal Words and Safety Alert Symbols Used in this Manual

WARNING Statements that indicate a hazardous situation which, if not avoided, could result in death or serious injury.

CAUTION Statements that indicate a hazardous situation which, if not avoided, could result in minor or moderate injury.

NOTICE Statements that indicate a hazardous situation which, if not avoided, could result in damage to the equipment or other property.



Safety alert symbol indicating a potential personal injury hazard.



Safety alert symbol indicating a potential for personal injury from electrical shock.

Safety Information



WARNING

Danger of death by electric shock

- If the power cord is damaged, electrically live parts may cause death if touched directly.
- Do not allow the tool to run unattended.
- The tool should be connected to a ground fault circuit interrupt (GFCI) protected outlet.
- Work on electrical equipment must be done by a qualified electrician.
- Switch off the tool, allow it to run until it stops rotating and remove the plug from the power outlet before changing tooling, maintaining, or transporting the tool.

**WARNING****Danger of eyes being injured by hot and sharp-edged metal chips.**

Eye protection must be worn while operating or working near the equipment.

**WARNING****Keep dry. Equipment and components are not waterproof.**

Do not use electric tools in a damp or wet environment.

**WARNING****Fire or Explosion**

Do not use in close proximity to flammable liquids or gases.

**WARNING****Danger of being injured by sharp cutting edges**

- Do not touch the cutting insert while the tool is operating.
- Wear safety gloves.
- Do not remove chips or tubing from the work area when the tube facing tool is still running and the tool is not yet at rest.
- Wear safety gloved to remove chips. Remove long and bent chips with needle-nose pliers.

**WARNING****Danger of being injured by rotating parts.**

Keep hands, loose clothing, and long hair away from rotating and moving parts.



WARNING

Observe the following safety measures in order to protect against risk of injury.

- Inspect the tube facing tool daily for visible signs of damage or defects. Have any damage or defects repaired immediately.
- Always ensure that the machine is in good working order and comply with these notes on safety.
- Only use the tube ODs, wall thickness, and materials specified in these instructions. Other materials should be used only after consulting your authorized Swagelok representative.
- Check that the work piece is correctly clamped.
- Do not carry the tube facing tool by the power cord and do not use the cord to pull out the plug. Protect the cable from heat, oil and sharp edges (chips).
- Before and during the facing of tubing, ensure that the viewing window is closed.
- Always work with sharp cutting tools to reduce vibrations.
- Turn the tool off and wait until it stops rotating when work is complete.

Environmental Protection/Disposal

- Dispose of chips and used gear lubricant oil according to local regulations.

Electric tools and accessories contain a large share of valuable raw and synthetic materials, which can be recycled. Therefore:

- Electrical (electronic) devices that are marked with the symbol in Fig. 1, may not be disposed of with household waste in accordance with European Union (EU) regulations.
- By using local return and collection systems, you contribute to the reuse, recycling and utilization of electrical (electronic) devices.
- Electrical (electronic) used devices contain parts, which must be handled selectively according to EU regulations. Separate collection and selective treatment is the basis for environment-friendly disposal and the protection of human health.



Fig. 1 RL 2002/96/EC Symbol

Product Information

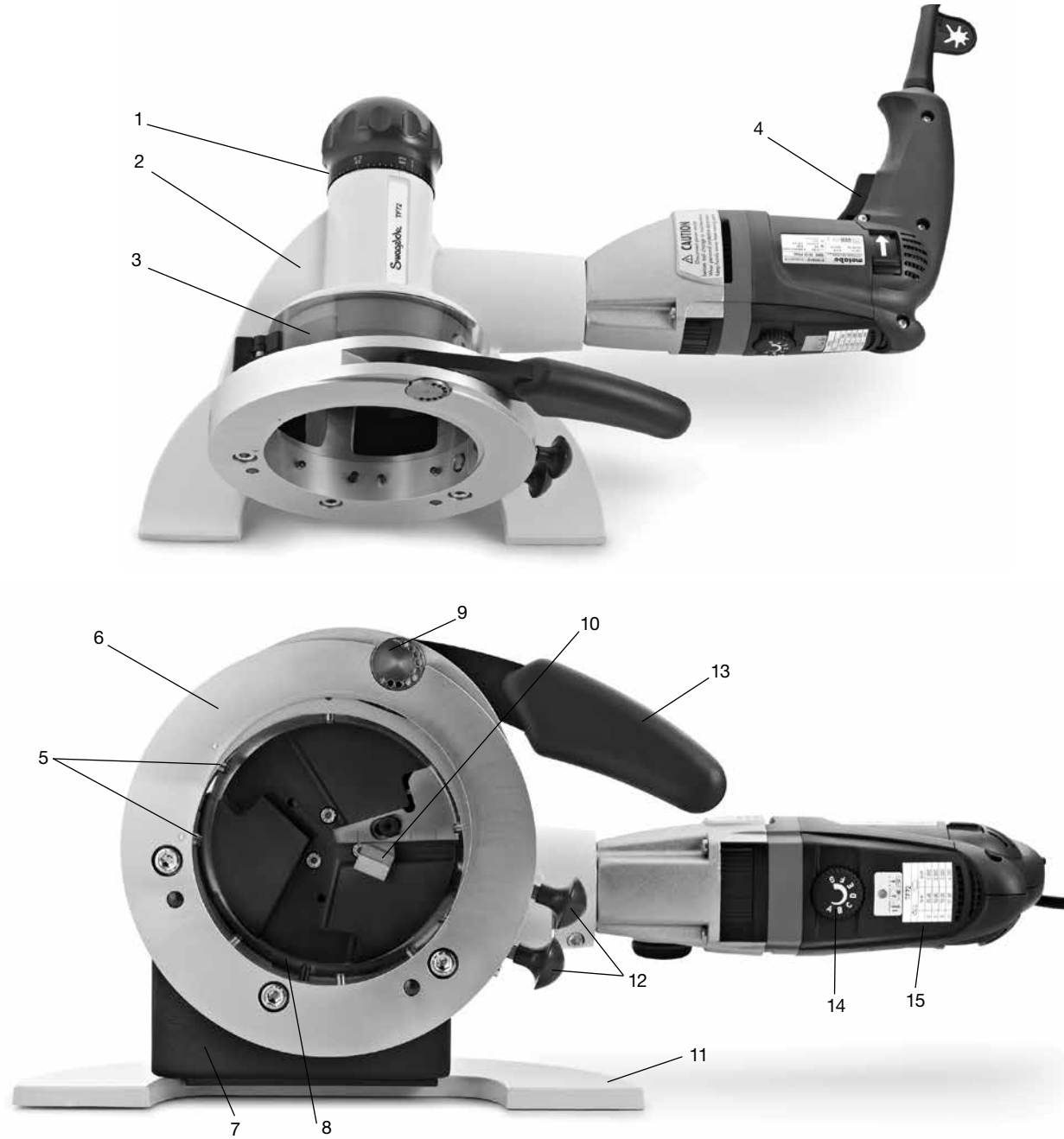

Fig 2 TF72 Series

- | | |
|------------------------------------|-----------------------------------|
| 1 Feed handle with scale divisions | 9 Tube clamp adjustment dial |
| 2 Housing | 10 Tool holder and cutting insert |
| 3 Viewing window | 11 Bench mount bracket |
| 4 ON/OFF switch | 12 Collet locks |
| 5 Collet guide | 13 Tube clamps |
| 6 Collet housing | 14 Speed adjustment dial |
| 7 Chip container | 15 Motor |
| 8 Tool mounting plate | |

Accessories

TF Series Cutting Insert

The cutting insert is supplied and can be used with all TF series tool holders.



Fig 3 Cutting Insert

Cutting Tool Holder for Beveling and Squaring

An adjustable tool holder is included with a Torx screw. Additional tool holders with different bevel angles are available.



Fig 4 Cutting Tool Holder

Stainless Steel Collet Set

These are used for deformation-free clamping of tubing. They ensure precise mounting of tubing or Micro-Fit® fittings and a quick change of collet sets without tools. For use on all tubing materials with an OD from 1.00 to 4.50 in. (25.4 mm to 114 mm).

See *Tube Facing Tools*, MS-02-426, for additional information on the optional accessories.



Fig 5 Stainless Steel Collet Set

Specifications

Application range

Series	TF72
Tube OD min. to max. range	1/2 to 4 1/2 in. / 12 to 114.3 mm)
Wall thickness max	0.118 in. / 3.0 mm

Tube materials

- Stainless steel
- Nickel alloys - ex. Alloy 600, Alloy 625, Alloy 825
- Aluminum

Contact your authorized Swagelok representative for information on additional materials.

Technical data

Series	TF72
Dimensions, in. (mm)	20.7 W, 10.1 H, 8.9 D (525 W, 256 H, 226 D)
Weight Without Accessories, lb (kg)	22.5 (10.2)
Input voltage	Single-phase alternating current, protection class II 110 V 50/60 Hz 230 V 50/60 Hz
Power, W	1100
Speed, r/min	0 to 52
Sound level (EN 23741), dB	Approx. 83
Vibration level (EN 50144), m/s²	2.5
Service Current Requirement, A	10 minimum

Setup

Description

The tube facing tool is designed for facing and preparing tube ends for welding in conformance with industry standards. It has the following properties:

- A cutting tool with multiple cutting edges. Only one cutting tool is necessary for different tube wall thicknesses (up to 0.118 in./3 mm) and different tube materials (exclusively ferrous materials).
- A speed-controlled electric motor with speed stabilization
- Restart protection to prevent the machine from starting in an uncontrolled way after it has been reconnected to the electrical power or after a power failure
- A quick change system for collet sets
- A feed dial with scale divisions:
 - Total travel: 0.591 in. (15 mm)
 - Travel per rotation: 0.118 in. (3 mm)
- A viewing window that provides protection.

Unpacking the Tube Facing Tool

Shipping Case Contents

- 1 Tube facing tool
- 1 Bench mount bracket
- 1 Tool holder with 1 cutting insert
- 1 Breakaway
- 1 Chip tray
- 1 Tool set (4 mm T-handle hex key, T15 Torx driver)
- 1 User manual

Report any missing or damaged parts to your authorized Swagelok representative immediately.

Installation of the Cutting Insert and the Tool Holder

CAUTION

Do not touch the sharp cutting edges while mounting the multifunctional tool. Wear protective gloves.

Cutting Insert

Attach the cutting insert to the tool holder with the curved side of the insert away from the tool holder. Use the included T15 Torx driver to tighten the screw.

Tool Holder

CAUTION

Allow the tool to run until it stops rotating and unplug the tool before changing tooling, performing maintenance, or transporting the tool.

1. Install the tool holder into the guiding groove of the tube facing tool housing.
2. Press the tool holder against the housing and tighten the set screw using the 4 mm T-handle hex key.

Note: The tool holder must be flush with the housing.

The tool mounting plate offers different tool holder mounting options, according to the size of the tube.



Fig 6 Installing the Cutting Insert



Fig 7 Installing the Tool Holder

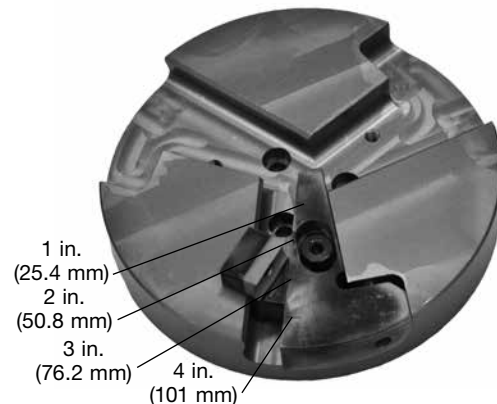

Fig 8 Tool Mounting Plate

Installing the Collet Set

1. Select the correct collet set according to the tube OD.
2. Move the tube clamp to the open position.
3. Place the lower collet in the housing at the collet guide. Slide the lower collet clockwise until the collet locks lock into place.
4. Place the upper collet in the housing at the collet guide. Slide the upper collet counter clockwise until the collet locks lock into place.

Removing the Collet Set

To remove a collet set, pull the collet locks until the collet set can be removed.

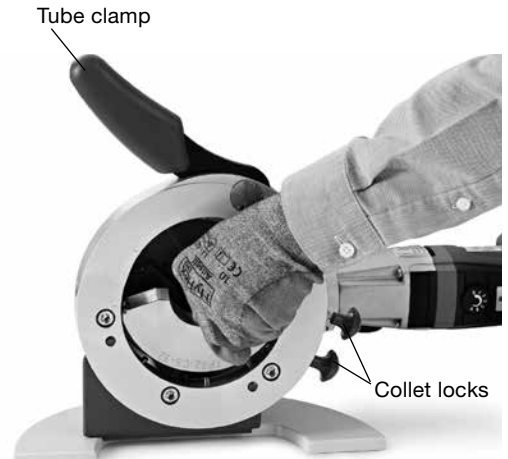

Fig 9 Install the Lower Collet

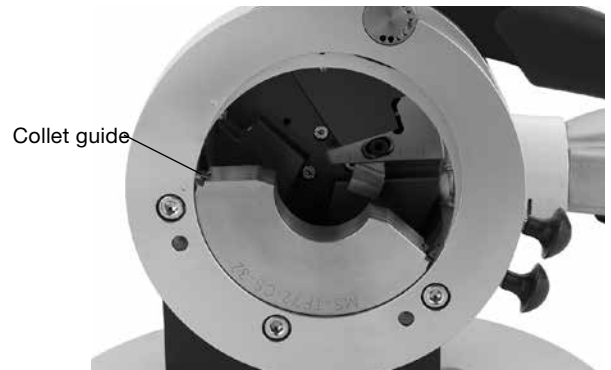

Fig 10 Install the Lower Collet, close-up

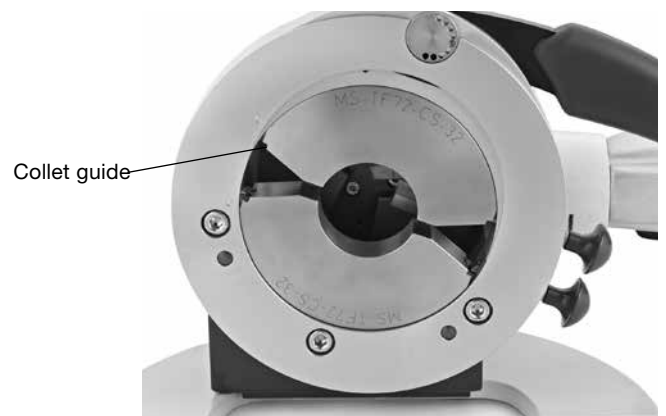

Fig 11 Install the Upper Collet

Operation

The tool should only be operated using a ground fault circuit interrupt (GFCI) protected outlet.

Adjusting for Tube Size

The TF72 series can be adjusted using the tube clamp adjustment dial to compensate for variations in tube tolerances. The adjustment dial has three marks: • (the factory setting), +, and -.

The adjustment options are as follows:

	Tube size is nominal.	Tube size is smaller than nominal.	Tube size is larger than nominal.
Position of tube clamp	Position of the tube clamp is correct.	The tube clamp rests on the tool frame and will not clamp tube.	The tube clamp cannot be lowered.
Adjustment required towards:	•	-	+

1. Lift the tube clamp and remove the tube, if necessary.
2. Loosen the socket screw on the tube clamp adjustment dial using the provided 4 mm T-handle hex key.
3. Turn the tube clamp adjustment dial in the needed direction. Allow the pin to engage into the adjustment dial.
4. Tighten the socket screw on the tube clamp adjustment dial using the provided 4 mm T-handle hex key.



Fig 12 Tube Clamp Adjustment Dial



Fig 13 Loosening the Socket Screw

Clamping the tube

CAUTION

Support long pieces of tubing with suitable fixtures. Injury from tilting tool and/or tilting tubing could result.

CAUTION

Verify that the tube facing tool is not rotating before clamping the tube.

NOTICE

The cutting tool can be damaged by incorrect set up. Before clamping the tube, verify there is space between the cutting insert and the tube.

1. Open the collets by lifting the tube clamp counterclockwise until it stops to open the collets.
2. Insert the tube in the collet set of the tube facing tool.
3. Secure the tube by lowering the tube clamp clockwise until it stops.

Note: Clamp the tube squarely, ensuring that the tube and the face of the collet set are perpendicular to each other. The tube end will not have a right angle cut when this is not true.

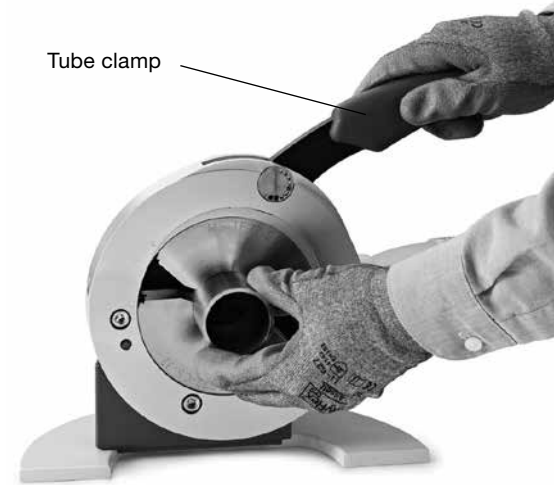

Fig 14 Clamping the Tube

Removing the Tube

To remove the tube from the facing tool, lift the tube clamp until it stops.

Tool Speed Range

Adjusting the Speed

Set the speed by turning the speed dial.

TF72	
Level	Tube OD, in. (mm)
D	1.0 (25.4)
C	1.5 (38.1)
C	2.0 (50.8)
B	2.5 (63.5)
B	3.0 (76.2)
A	3.5 (88.9)
A	4.0 (102)
A	4.5 (114)



Fig 15 Speed Dial

Facing the Tube



WARNING

Allow the machine to run until it stops rotating after cutting tube to avoid injury.



WARNING

Do not touch the tool holder or cutting insert while the tool is in operation.



WARNING

Only operate the tool with a clamped tube and a closed viewing window.



WARNING

Eye protection must be worn while operating or working near the equipment.



WARNING

Keep hands, loose clothing, and long hair away from rotating and moving parts.



WARNING

Wear safety gloves to remove chips. Remove long and bent chips with needle-nose pliers or a similar tool.

NOTICE

Excessive feed of the cutting insert into the tube can damage the cutting tool or cause the tool to overheat.

NOTICE

Verify there is space between the cutting tool and the tube before clamping the tube to prevent damage to the cutting tool. The cutting tool can be damaged by a tube not cut at a right angle.

NOTICE

If speed is reduced too quickly, the tool may “dig” into the tube, causing damage to the tube face and the tool, and may cause the tool to stop. Reduce the feed rate of the cutting insert and the tool speed gradually.

NOTICE

Verify the motor is in drill mode if the motor is equipped with a hammer mode. Operating the tool in hammer mode will cause damage to the tool and the tube.

Turning “On” the TF72 Series

1. Check that the viewing window is closed, close if necessary.
2. Set the desired speed via the speed adjustment dial.
3. Activate the ON/OFF switch.

Note: If the tool vibrates after starting, the cutting speed is too high. Reduce the speed according to **Adjusting the Speed**.

Facing the Tube

- Each division on the feed dial with scale adjustments equals an advancement of 0.002 in. (0.05 mm).
 - It is recommended not to exceed a chip thickness of 0.002 in. (0.05 mm) while facing the tube. Excessive feed levels will reduce the speed or stop the machine.
1. Slowly advance the cutting insert until it is in contact with the tube.
 2. Continue advancing the cutting insert until the desired result is achieved.

Note: To achieve the optimum squareness and finish, the tool should be allowed to rotate for 2 to 3 revolutions without further advancement of the cutting insert.

3. Release the ON/OFF switch.
4. Remove the tube by turning the tube clamp counterclockwise until it stops.

Maintenance

CAUTION

Allow the tool to run until it stops rotating and unplug the tool before changing tooling, maintaining, or transporting the tool.

When cleaning the tube facing tool, clear the collet set and tool body of debris and dirt.

When changing the cutting insert, clean the tool holder and inspect it for damage.

Breakaway Nut Replacement

Note: The ordering number for a replacement breakaway nut is MS-TF-ADAPTER-2.

1. Verify the tool is unplugged.
2. Loosen the M5 × 16 set screw using the provided 4 mm hex key.
3. Remove the collet housing half of the tool.
4. Remove the breakaway nut using a 19 mm deep-socket ratchet wrench.
5. Install the new breakaway nut. Securely tighten the breakaway nut to the motor shaft.
6. Replace the collet housing half and tighten the M5 × 16 set screw.



Fig 16 Loosening the Set Screw



Fig 17 Removing the Collet Housing Half of Tool



Fig 18 Removing the Breakaway Nut



Fig 19 Breakaway Nut Removed from Tool

Troubleshooting

Problem	Cause	Remedy
Cutting insert is causing a "step" during facing.	The cutting insert has been fed too far into the tube.	Take tube out of the tool and disassemble the tool holder.
		Remove chips using pliers. File down the step.
	Slowly advance the cutting insert towards the tube during new cutting.	
	Cutting insert or tool holder is loose.	Tighten the cutting insert or the tool holder.
The tube clamp does not clamp correctly or has too much play.	The tube dimensions deviate from what the tool has been set for.	Adjust the tool according to Adjust the Tube Clamp .
The motor is not running but signal light is on.	Quick flashing light - The restart inhibitor has activated.	Switch the tool off and back on. For safety reasons, the tool will not restart automatically after a power failure.
	Slow flashing light - The carbon brushes are worn out.	Have the carbon brushes replaced by your authorized Swagelok sales and service representative.
	Constant light - The motor has overheated.	Unplug the tool and allow it to cool.
Tool has excessive vibration.	Speed is too high.	Reduce the speed.
	Axial or radial play in the components.	Check that the collet set is properly secured.
	Cutting insert is loose.	Tighten the cutting insert.
The finished tube face is not smooth or has a large burr.	Cutting insert is worn.	Replace the cutting insert.

Warranty Information

Swagelok products are backed by The Swagelok Limited Lifetime Warranty. For a copy, visit [swagelok.com](https://www.swagelok.com) or contact your authorized Swagelok Representative.