

Stream Selector System

For Process Analyzer Applications



SSV Series

- Provides double-block-and-bleed (DBB) operation in a single compact module
- Conventional NPT and ANSI/ISA 76.00.02 compatible designs
- System pressures to 250 psig (17.2 bar) with 40 psig (2.8 bar) actuation pressure
- Integrated flow loop to provide consistent outlet flow
- Large colored visual indicator ring for open position

Contents

Stream Selector System for Process Analyzer Applications	2
Features	2
Flow Schematic	2
Materials of Construction	3
Technical Data	3
Pressure-Temperature Ratings	3
Testing	3
Cleaning and Packaging	3
Typical SSV Three-Stream System	4
DBB Module	4
Base Blocks	5
Atmospheric Reference Vent Option	6
High-Purge Option	7
MPC-Compatible Interface Option	8
Ordering Information and Dimensions	9
Options	10
Replacement Part Kits	11

Stream Selector System For Process Analyzer Applications

The Swagelok® stream selector system (SSV series) is a modular assembly designed for process analyzer sampling systems. The SSV series system can accommodate multiple process streams with each stream controlled by a DBB module. Each DBB module features a double block-and-bleed design to eliminate cross-contamination of sample streams. The SSV series system also features an integrated flow loop that provides consistent outlet flow and ensures fast and efficient purging.

Features

- Modular design offers ease of installation and maintenance.
- Built-in pneumatic actuator provides repetitive shutoff with fewer potential leak points than conventional systems.
- Distinctive vented air gap prevents mixing of pneumatic actuator supply and system fluid under pressure.
- Compact design saves cabinet space and reduces internal volume.
- Stainless steel construction provides enhanced corrosion resistance.
- Inlet and outlet connections are 1/8 in. female NPT or MPC compatible (ANSI/ISA 76.00.02)
- Optional integrated atmospheric reference vent (ARV) is available.

Flow Schematic

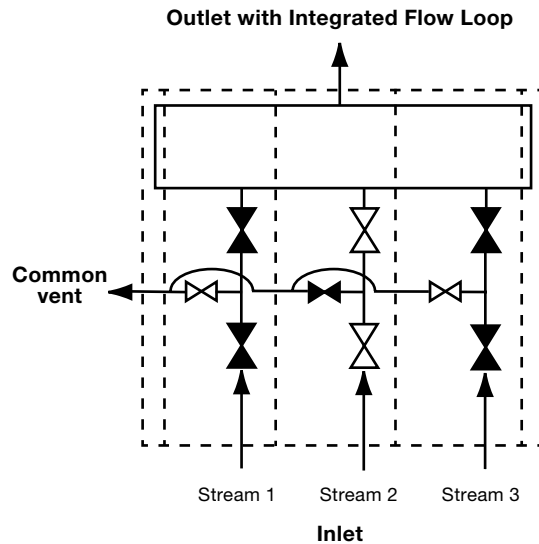

Materials of Construction

Component	Material Grade / ASTM Specification
1 Cap	Nylon
2 Piston	316 SS / A479
3 Piston seal	Fluorocarbon FKM
4 Body	CF3M / A351
5 Upper stem seal	Fluorocarbon FKM
6 Stem	316 SS / A479
7 Spring	S17700 stainless steel
8 Lower stem seal	Fluorocarbon FKM
9 Vent seal	
10 Boss seal	
11 Body seal	
12 Double block seal	
13 Flange	316 SS / A479
14 Base block seal	Fluorocarbon FKM
15 Base block	316 SS / A479
16 Insert	316 SS / A479
All port plugs (not shown)	316 SS / A479 with PTFE tape
All cap screws (not shown)	18-8 SS
Actuation air seals (not shown)	Fluorocarbon FKM
Wetted lubricant	PTFE-based

Wetted components listed in *italics*.

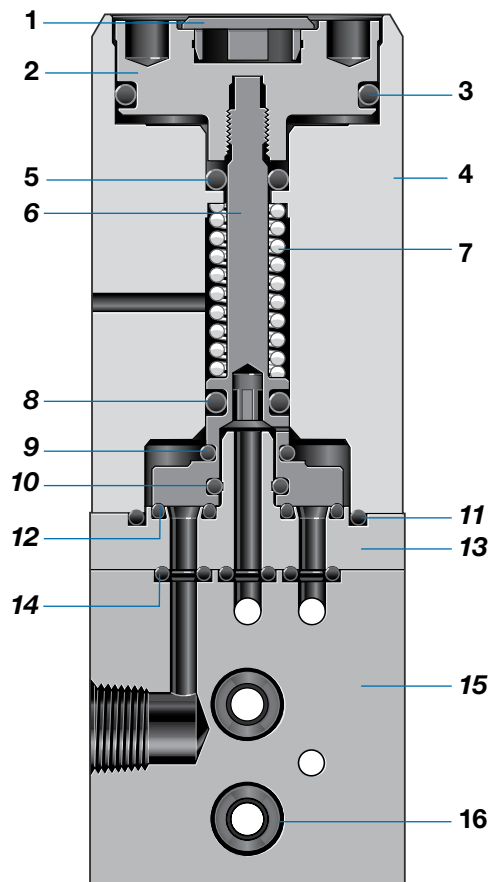

Technical Data

Bore Size in. (mm)	Flow Coefficient (C_v) (Standard system with three streams)		
	Stream 1	Stream 2	Stream 3
0.125 (3.2)	0.20	0.20	0.20

Pressure-Temperature Ratings

Temperature °F (°C)	Working Pressure psig (bar)	Actuator Pressure Rating psig (bar)	Minimum Actuation Pressure psig (bar)
20 (-6)	200 (13.7)	40 to 150 (2.8 to 10.3)	45 (3.2)
30 (-1)	250 (17.2)		40 (2.8)
100 (37)			
300 (148)			

Testing

Every Swagelok SSV system is factory tested at room temperature with nitrogen at 250 psig (17.2 bar). Each double block-and-bleed seat has a maximum allowable leak rate of 0.1 std cm³/min. Shell testing is performed to a requirement of no detectable leakage with a liquid leak detector.

Cleaning and Packaging

All Swagelok SSV systems are cleaned and packaged in accordance with Swagelok *Standard Cleaning and Packaging (SC-10)* catalog, [MS-06-62](#).

Typical SSV Three-Stream System

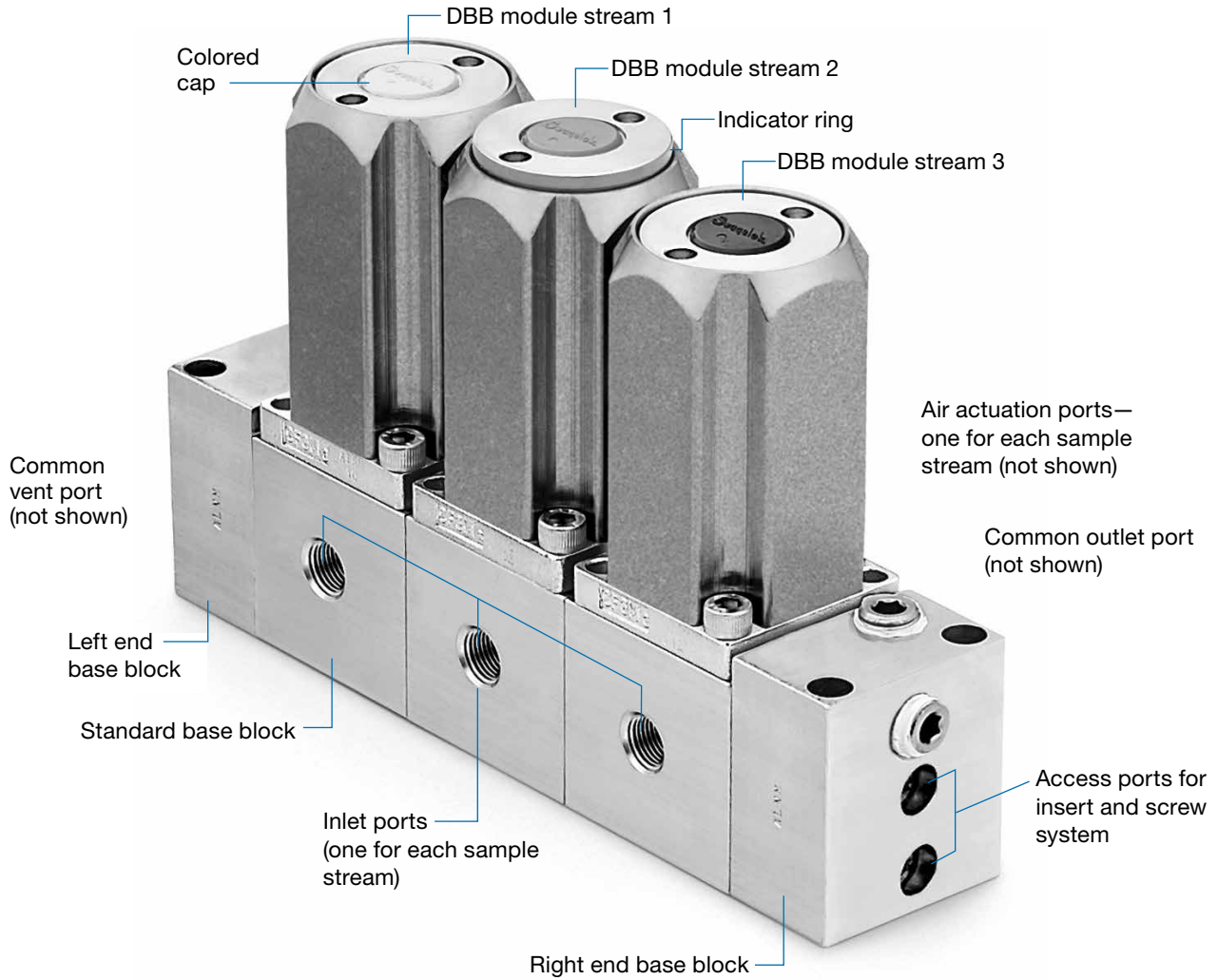

DBB Module

Each individual DBB module consists of a pneumatic actuator and a flange. Multiple DBB modules are connected with base blocks to create the stream selector system.

- One-piece, integrated DBB module allows for easy removal without the need to disconnect process lines.
- Normally closed, double block-and-bleed design consists of:
 - Double-block valves that control system fluid and eliminate cross-contamination of sample streams
 - Bleed valve that is tied to a common vent for all DBB modules.
- Distinctive vented air gap and double seal between pneumatic actuator air and system fluids to prevent mixing of air and fluid under pressure.
- Visual indicator provides easy visual and tactile indication of open position with large, raised green ring.
- Interchangeable colored caps provide stream identification. (Standard color is blue.)

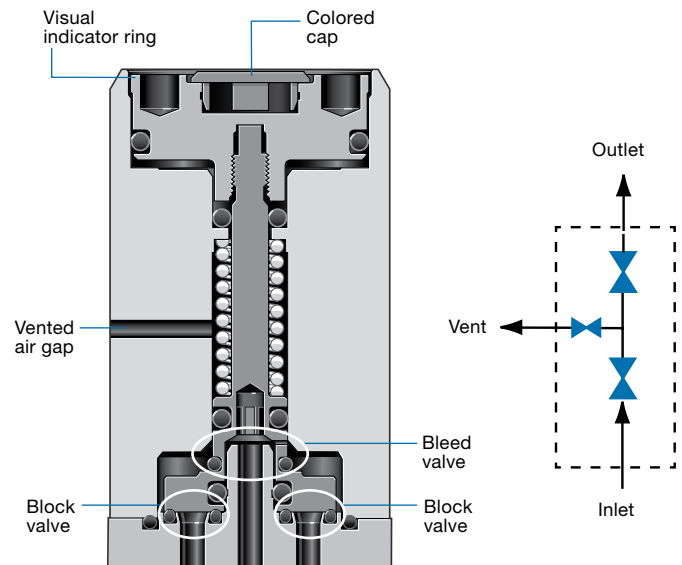

Base Blocks

- Types of base blocks include standard, outlet, end (left and right), and ARV (optional).
- Blocks are attached together with a patent-pending insert and screw system to create a fluid path.
- Blocks contain all the fluid connections in one location.

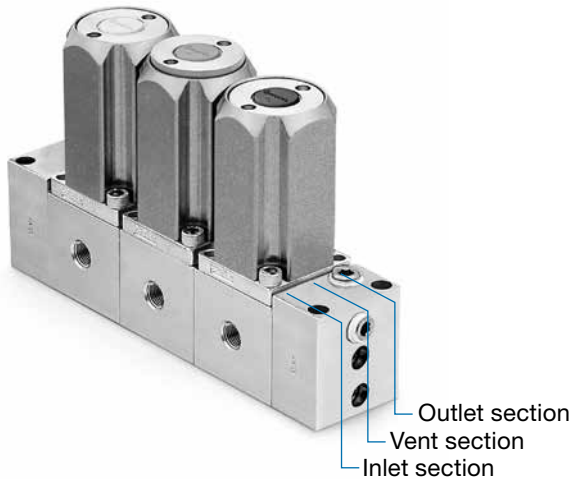

Internal Porting

Inlet Section (Sample Stream Inlet Ports)

- 1/8 in. female NPT is standard inlet port connector.
- MPC-compatible (ANSI/ISA 76.00.02) connections are available.

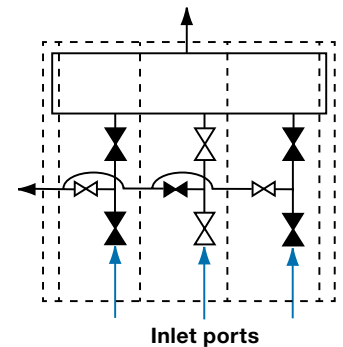
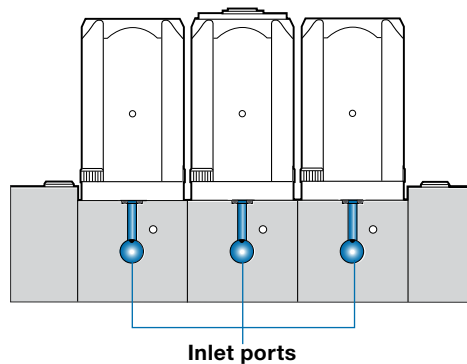

Vent Section (Common Vent and Block Connectors)

- Vent port has 1/8 in. female NPT for both conventional and MPC configurations.
- All DBB modules bleed to a common vent line.
- Insert screws between blocks are tightened separately to ensure proper assembly and disassembly.
- Recessed insert screws are captive within each block for ease of assembly and to eliminate misplacing.

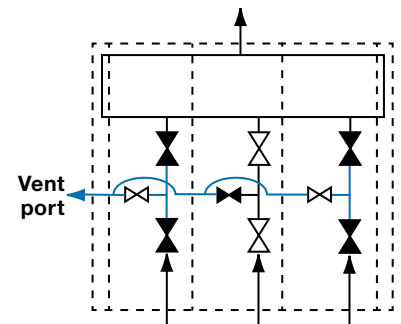
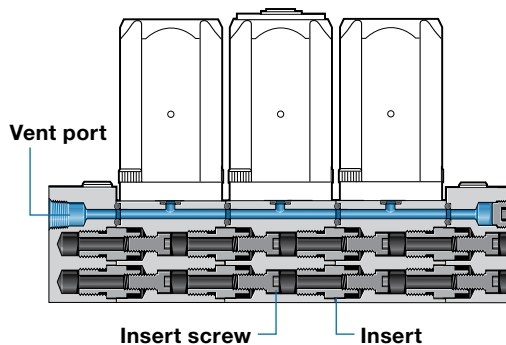

Outlet Section (Integrated Outlet Flow Loop)

- Integrated outlet flow loop allows for fast and efficient purging.
- Provides consistent C_v from one module to another regardless of the addition of multiple modules.

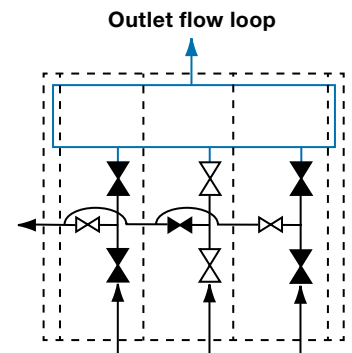
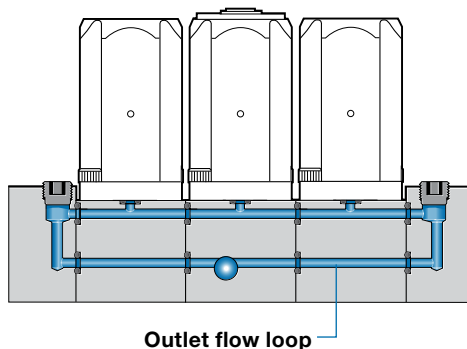

Atmospheric Reference Vent Option

The integrated atmospheric reference vent (ARV) is positioned prior to the analyzer and attached to the outlet of the stream selector system. It is designed to equalize the sample loop pressure to atmospheric pressure just prior to the sample injection. This ensures a constant sample pressure in repetitive analyses.

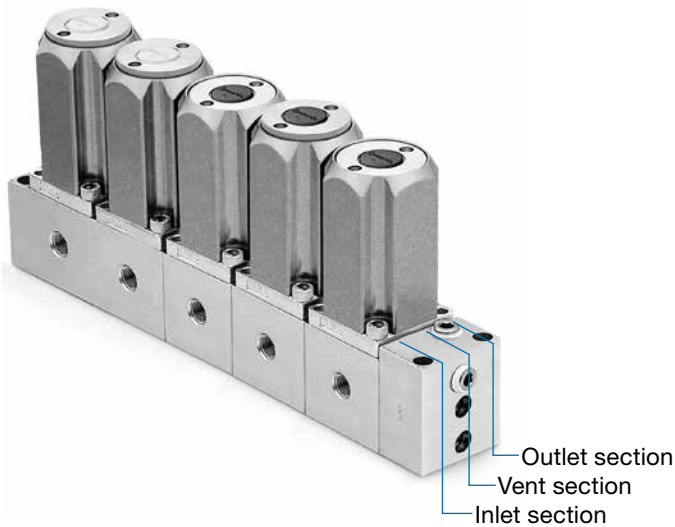

Inlet Section

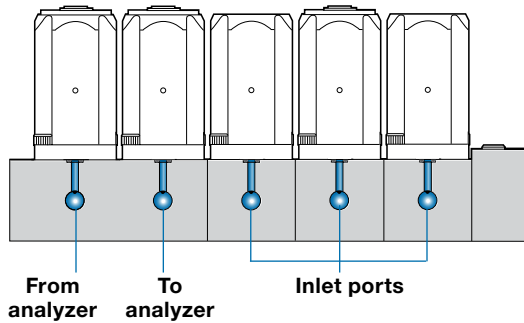

Vent Section

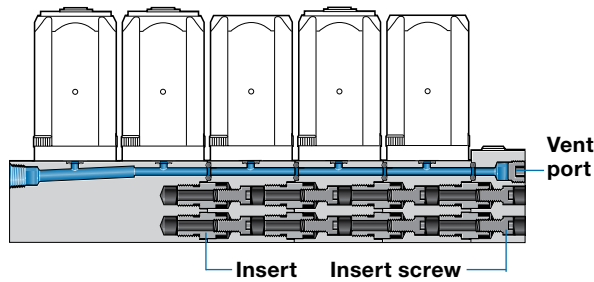

Outlet Section

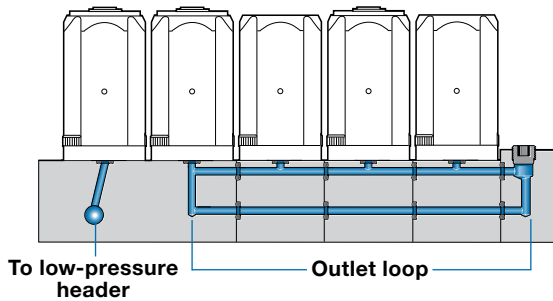

Operation

Vent

All valves are in the *off* position. The analyzer is *open* to vent.

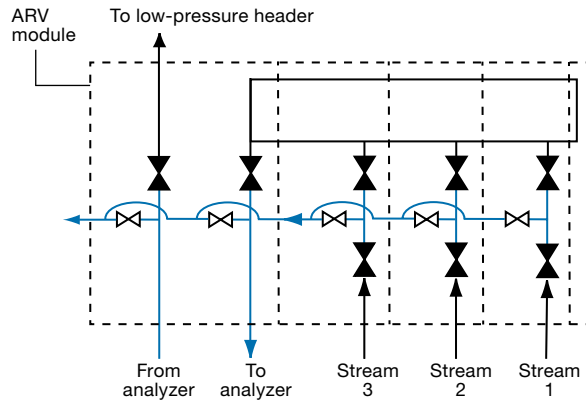

Sample

Stream 2 and the ARV module are in the *on* position, flowing the outlet loop to the low pressure header.

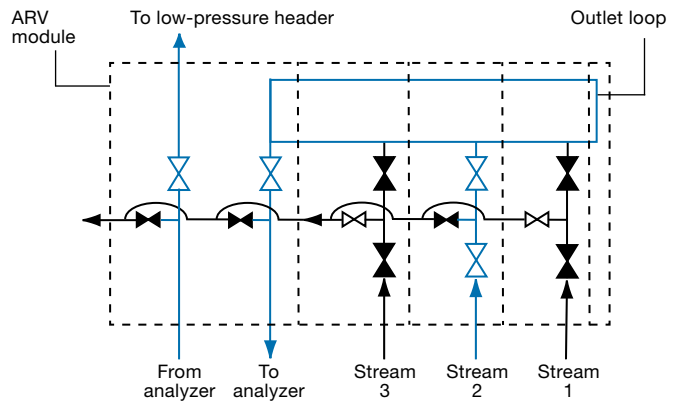

Vent

Stream 2 is in the *on* position and the ARV module is in the *off* position, equalizing the analyzer to the vent pressure.

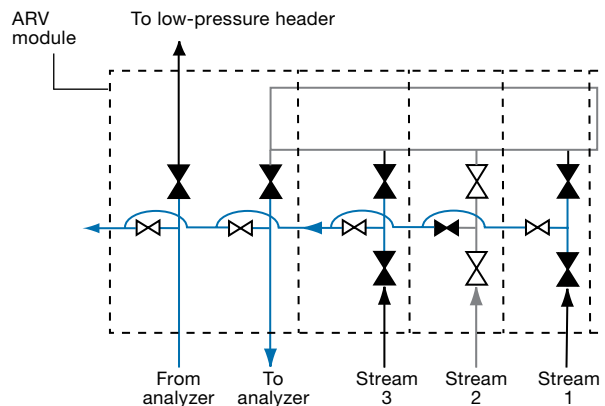

High-Purge Option

The high-purge flow loop option provides increased purgeability and cleanliness for applications requiring a high degree of sample purity.

A unique base block and valve flange divert the outlet flow up into the outlet port of each closed stream, providing a fully swept flow path to the analyzer.

The result is rapid delivery of a high-purity sample to the analyzer. In tests using water at a flow rate of 100 std cm³/min for three sample streams, impurity levels dropped below 1 % percent within 12 seconds, as shown in the graph below.

The high-purge option is available on standard and outlet SSV and MPC models; the high-purge SSV components employ a different interface design from standard SSV components and cannot be interchanged with other SSV models.

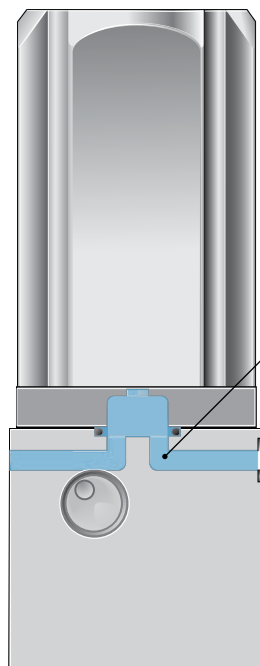

Flow path to the analyzer is fully swept, enhancing the rate of system purging.

Impurity Level After Stream Switching

Liquid test flow rate: 100 std cm³/min

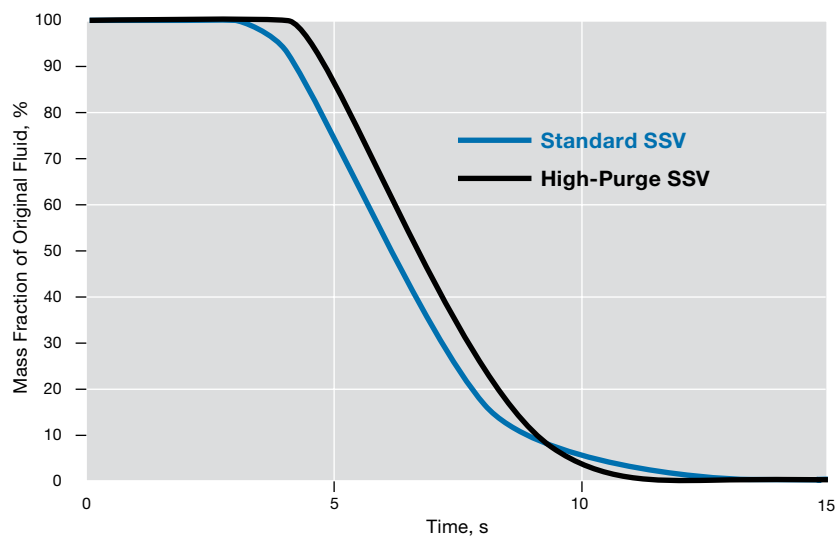

MPC-Compatible Interface Option

- The Swagelok stream selector system with a special bottom porting can be mounted on an MPC substrate.
- Interface is compatible with ANSI/ISA 76.00.02 MPC platform.
- MPC option for the SSV system is included in the *MPC Configurator* for design assistance.



Note: The DBB module cannot be mounted to MPC substrate without base block.

Materials of Construction

For SSV system components, see **Materials of Construction**, page 3.

For MPC components, refer to Swagelok *Modular Platform Components (MPC)* catalog, [MS-02-185](#).

Cutaway of MPC-Compatible SSV System

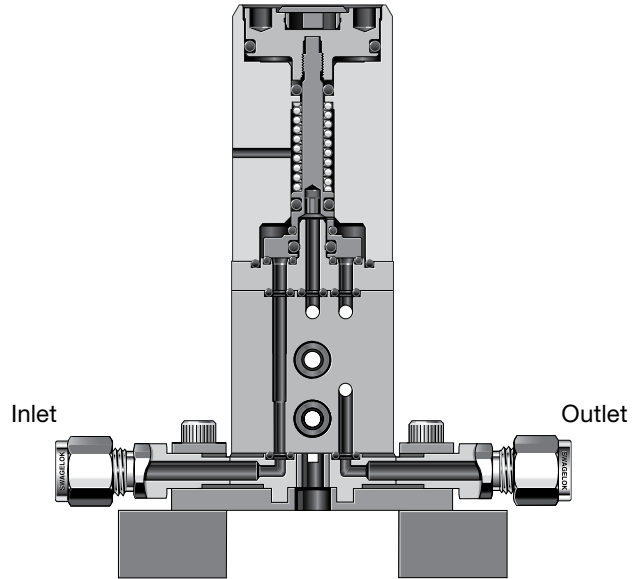

MPC Configurator Screen with SSV Layout

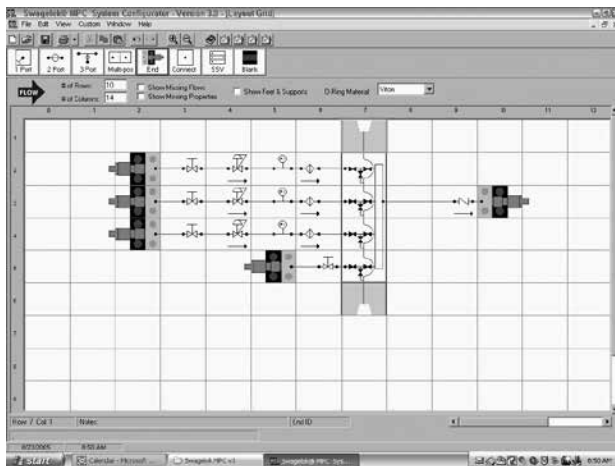

The *MPC Configurator* is available to download from your Swagelok website.

Bottom View of MPC-Compatible SSV System

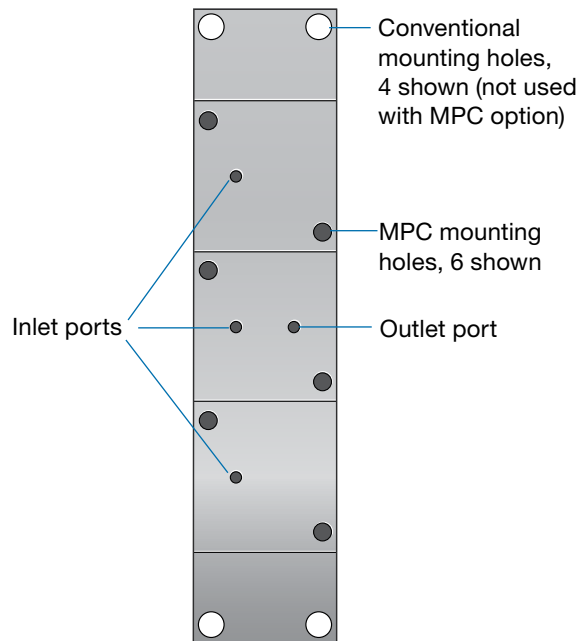

Ordering Information and Dimensions

Dimensions are for reference only and are subject to change.

Top

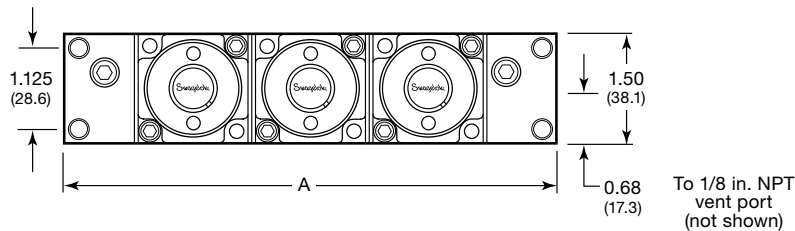

Front (Inlet Side)

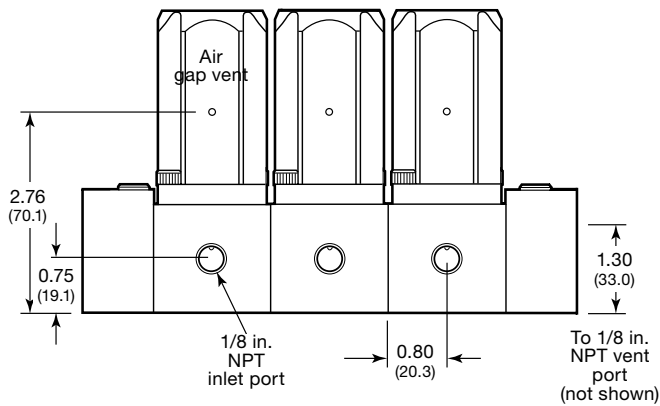

Back (Outlet Side)

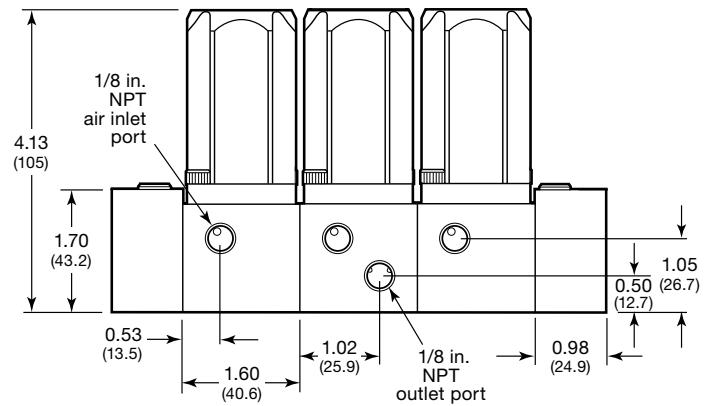

Stream Selector System Assembly

Select an ordering number.

To order a Swagelok SSV system with more than 12 streams, contact your authorized Swagelok representative.

Number of Streams	SSV System			With Atmospheric Reference Vent	
	Standard SSV Ordering Number	High-Purge SSV Ordering Number	A in. (mm)	Ordering Number	A in. (mm)
2	SS-SSV-V-2-F2	SS-SSVP-V-2-F2	5.15 (131)	SS-SSV-V-2-F2-ARV	7.77 (197)
3	SS-SSV-V-3-F2	SS-SSVP-V-3-F2	6.75 (171)	SS-SSV-V-3-F2-ARV	9.37 (238)
4	SS-SSV-V-4-F2	SS-SSVP-V-4-F2	8.35 (212)	SS-SSV-V-4-F2-ARV	10.97 (279)
5	SS-SSV-V-5-F2	SS-SSVP-V-5-F2	9.95 (253)	SS-SSV-V-5-F2-ARV	12.57 (319)
6	SS-SSV-V-6-F2	SS-SSVP-V-6-F2	11.55 (293)	SS-SSV-V-6-F2-ARV	14.17 (360)
7	SS-SSV-V-7-F2	SS-SSVP-V-7-F2	13.15 (334)	SS-SSV-V-7-F2-ARV	15.77 (401)
8	SS-SSV-V-8-F2	SS-SSVP-V-8-F2	14.75 (375)	SS-SSV-V-8-F2-ARV	17.37 (441)
9	SS-SSV-V-9-F2	SS-SSVP-V-9-F2	16.35 (415)	SS-SSV-V-9-F2-ARV	18.97 (482)
10	SS-SSV-V-10-F2	SS-SSVP-V-10-F2	17.95 (456)	SS-SSV-V-10-F2-ARV	20.57 (522)
11	SS-SSV-V-11-F2	SS-SSVP-V-11-F2	19.55 (497)	SS-SSV-V-11-F2-ARV	22.17 (563)
12	SS-SSV-V-12-F2	SS-SSVP-V-12-F2	21.15 (537)	SS-SSV-V-12-F2-ARV	23.77 (604)

Options

MPC-Compatible Interface

The Swagelok SSV system is offered with an optional MPC-compatible interface (ANSI/ISA 76.00.02) for up to ten streams.

To order the MPC interface option, replace **F2** in the valve ordering number with **MPC**.

Example: SS-SSV-V-2-MPC



Vented Air Gap Threaded Test Port

An optional 1/8 in. female NPT threaded test port is available for the vented air gap.

To order a Swagelok SSV system with threaded test ports, insert **T** into the valve ordering number as shown.

Example: SS-SSV-VT-2-F2

Kalrez® and Simriz® Seals

Optional seals are available in place of the *wetted* fluorocarbon FKM seals. For pressure-temperature ratings, see table below.

To order a Swagelok SSV system with Kalrez seals, replace **V** in the valve ordering number with **K**.

Example: SS-SSV-K-2-F2

To order a Swagelok SSV system with Simriz seals, replace **V** in the valve ordering number with **Z**.

Example: SS-SSV-Z-2-F2

Temperature °F (°C)	Working Pressure psig (bar)
Kalrez and Simriz Seals	
30 (-1)	200 (13.7)
40 (4)	250 (17.2)
70 (20)	250 (17.2)
300 (148)	250 (17.2)

Electronic Position Sensors

SSV system modules are available with electronic position sensors, which transmit a signal to an electrical device indicating the *closed* position of SSV series stream selector valves.



Features

Standard industrial and intrinsically safe sensor models are available. Both models:

- offer instant, remote confirmation of valve actuator position
- validate valve response

The industrial model aids troubleshooting with a local LED indicator.

The intrinsically safe model is designed for use in applications where intrinsically safe ratings are required, such as hazardous environments or media.

Standard Industrial Sensor

Electrical Specifications

Turck Part Number	Bi 1-EH04-AP6X-V1131/S1164
Connection	Turck picofast® snap lock, 3-pin (PKG 3Z cable)
Output	3-wire V (dc)—transistor (PNP current-sourcing)
Voltage	10 to 30 V (dc) polarity protected—pulsed SCP
Output Function	Normally open
Operating Temperature	-23 to 70°C (-10 to 158°F)

Wiring Diagram

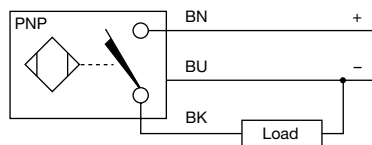

Intrinsically Safe Sensor

Electrical Specifications

Turck Part Number	Bi 1-EH04-Y1-V1130/S1164
Connection	Turck picofast snap lock, 3-pin (PKG 3Z cable)
Output	2-wire NAMUR-style (IEC60947-5-6 [EN60947-5-6])
Voltage	NAMUR switch amplifier required
Output Function	Normally open
Operating Temperature	-23 to 70°C (-10 to 158°F)

Wiring Diagram

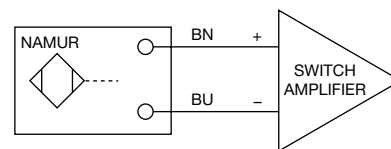

Ordering Information

To order an electronic position sensor factory assembled, add:

- PS** for a standard industrial sensor
 - PS-IS** for an intrinsically safe sensor
- to the valve ordering number.

Examples: SS-SSV-V-2-F2-PS

SS-SSV-V-3-MPC-PS-IS

Replacement Part Kits

Kits With Seals

Replacement part kits that include seals contain all fluorocarbon FKM seals. Kalrez seals and Simriz seals are available in place of the *wetted* fluorocarbon FKM seals. For pressure-temperature ratings, see the table on page 10.

To order *wetted* Kalrez or Simriz seals, replace **V** in the kit ordering number with **K** for Kalrez or **Z** for Simriz.

Examples: SS-1K-SSVM-**K**-F2-STD
SS-1K-1B-SSVM-**Z**

Stream Assembly Kit

Each kit includes a DBB module assembled to a base block.

Stream Assembly Type	Ordering Number
Standard SSV	
Standard	SS-1K-SSVM-V-F2-STD
Outlet	SS-1K-SSVM-V-F2-OUT
MPC standard	SS-1K-SSVM-V-MPC-STD
MPC outlet	SS-1K-SSVM-V-MPC-OUT
ARV	SS-1K-SSVM-V-F2-ARV
High-Purge SSV	
Standard	SS-1K-SSVPM-V-F2-STD
Outlet	SS-1K-SSVPM-F2-OUT
MPC standard	SS-1K-SSVPM-V-MPC-STD
MPC outlet	SS-1K-SSVPM-V-MPC-OUT



Base Block Kit

Each kit includes one base block assembled with inserts and insert screws.

Block Type	Ordering Number
Standard SSV	
Standard	SS-1K-SSVB-V-STD
Outlet	SS-1K-SSVB-V-OUT
Left end	SS-1K-SSVB-LEF
Right end	SS-1K-SSVB-V-RIT
MPC standard	SS-1K-SSVB-V-MPC-STD
MPC outlet	SS-1K-SSVB-V-MPC-OUT
ARV	SS-1K-SSVB-V-ARV
High-Purge SSV	
Standard	SS-1K-SSVPB-V-STD
Outlet	SS-1K-SSVPB-V-OUT
MPC standard	SS-1K-SSVPB-V-MPC-STD
MPC outlet	SS-1K-SSVPB-V-MPC-OUT



Flange Kit

Each kit includes a flange assembled with O-ring seals.

Standard SSV kit ordering number:

SS-1K-1B-SSVM-V

High-purge SSV kit ordering number: **SS-1K-1B-SSVPM-V**



Module Kit

Each kit includes a completely assembled module including the pneumatic actuator and flange.

Module Type	Ordering Number
DBB	SS-1K-SSVM-V
ARV	SS-1K-SSVM-V-ARV
High-purge DBB	SS-1K-SSVPM-V



O-Ring Seal Kit

Each kit includes the seals for one DBB module.

Ordering number: **SS-1K-9-SSVM-V**

Kits Without Seals

Cap Kit

This kit includes ten caps of the same color. To order, add the cap color designator to the basic kit ordering number: **MS-5K-SSVM**

Example: MS-5K-SSVM-**BL**



Cap Color	Designator
Black	-BK
Blue	-BL
Green	-GR
Orange	-OG
Red	-RD
Yellow	-YW
White	-WH

Screw Kit

This kit includes all cap screws for one stream assembly. Ordering number: **SS-6K-SSVM**

Safe Product Selection

When selecting a product, the total system design must be considered to ensure safe, trouble-free performance. Function, material compatibility, adequate ratings, proper installation, operation, and maintenance are the responsibilities of the system designer and user.

⚠ WARNING

Do not mix/interchange Swagelok products or components not governed by industrial design standards, including Swagelok tube fitting end connections, with those of other manufacturers.

Warranty Information

Swagelok products are backed by The Swagelok Limited Lifetime Warranty. For a copy, visit swagelok.com or contact your authorized Swagelok representative.

Swagelok—TM Swagelok Company
Kalrez—TM DuPont
Simriz—TM Freudenberg-NOK
picofast—Hans Turck KG
© 2009–2024 Swagelok Company
MS-02-326, RevH, May 2024