

# PRS4 and PRS8 Pressure-Reducing Regulator User Manual



**Read the complete manual before installing and using the regulator.**

## Safe Product Selection

When selecting a product, the total system design must be considered to ensure safe, trouble-free performance. Function, material compatibility, adequate ratings, proper installation, operation, and maintenance are the responsibilities of the system designer and user.



### WARNING

- Users must be trained and equipped for the handling, use, and servicing of pressure products and systems.
- Users must contact their gas or liquid supplier for specific safety precautions and instructions.
- Gaseous media should be free of excessive moisture to prevent icing at high flow.
- Always wear the appropriate protective clothing, including safety glasses, gloves, etc., if required.
- Follow the applicable safety and maintenance procedures.
- Obey specific local regulations.
- Do not exceed the maximum inlet and outlet pressure rating of the product or its accessories.
- Operate within the temperature limits and any other conditions specified for the product.
- Do not drop or damage the product in any other way. This may negatively affect the performance of the product which can cause the product to malfunction.
- Venting fluids and gases can be dangerous. Vent to a safe environment away from people. Ensure adequate ventilation.

## Contents

<b>Introduction</b> .....	<b>4</b>
Overview.....	4
Standard Features.....	4
Additional Options .....	4
Oxygen Service .....	4
<b>Installation</b> .....	<b>5</b>
Points of Attention Before Installation .....	5
Installation .....	5
<b>Operation</b> .....	<b>6</b>
Required Tools for Operation .....	6
Points of Attention Before Operation.....	6
Adjusting the Set Pressure.....	6
<b>Maintenance</b> .....	<b>7</b>
Required Tools for Maintenance .....	7
Points of Attention Before Removal from the System .....	8
Removal from the System .....	8
Assembly Reference Data.....	9
Disassembly .....	14
Points of Attention Before Reassembly.....	14
Reassembly.....	15
PRS4 Series .....	15
PRS8 Series .....	15
<b>Testing</b> .....	<b>16</b>
Seat Leak Test .....	16
Shell Leak Test.....	16
<b>Troubleshooting</b> .....	<b>17</b>

## Introduction

### Overview

- The PRS4 and PRS8 series are spring-loaded pressure-reducing regulators designed for high-sensitivity regulation of gases and liquids.
- For pressure and temperature rating information refer to the *Sanitary Pressure Regulators, RHPS Series* catalog, MS-02-436.



#### **WARNING**

**Check that system pressures and temperatures do not exceed those stated on the regulator as this could result in product failure.**

### Standard Features

- Threaded construction
- Stainless steel as standard
- Fully serviceable
- Diaphragm sensing
- Bottom mounting

### Additional Options

The regulator is available with the following options:

Anti-tamper

### Oxygen Service

- For more information about hazards and risks of oxygen enriched systems see the *Swagelok Oxygen System Safety* technical report (MS-06-13).
- Cleaning and packaging to ensure compliance with product cleanliness requirements stated in ASTM G93 Level C is provided as standard. Refer to the *Sanitary Pressure Regulators, RHPS Series* catalog, MS-02-436, for additional information.

## Installation



### CAUTION

Do not use the regulator as a shutoff device. A level of leakage across the regulator seat can occur during normal operation.

### Points of Attention Before Installation

This regulator can be equipped with a variety of different options. Before installing the regulator you should fully understand the functions of the supplied options and the suitability of your particular regulator for the intended application.

- The preferred mounting position of the regulator is horizontal with the spring housing facing upwards per Fig 2. Alternative mounting positions may increase the risk of component wear.
- It may be necessary to remove the regulator from the system during maintenance or service. Ensure that this is possible.
- The regulator is suitable for gases or liquids. Ensure compatibility between the regulator's materials of construction and the system media.

### Installation

- Verify that the regulator, its connections, and any accessories are undamaged.
- Verify that the regulator and any accessories are suitable for the system operating pressure and temperature and have suitable connections.
- At the time of delivery any gauge ports may be plugged with blind fittings. Remove these and connect gauges if desired.



### CAUTION

Ensure all upstream tubing/pipework is clean and free from debris. Any swarf, lint, wire, etc. may damage the regulator, resulting in a seat leak.

- Verify the flow direction of the system and mount the regulator accordingly.
- Securely make the appropriate connections to the regulator in accordance with the procedures recommended by the connection manufacturer.
- Ensure that the tubing/pipework and the regulator are adequately supported and that there is no stress on the connections.
- Upstream and downstream shutoff valves should be installed in the system to facilitate servicing, maintenance, and troubleshooting of the regulator.

## Operation

### Required Tools for Operation

- No tools are required for changing the set pressure on a standard regulator.
- A 20 mm open-ended wrench and a 13 mm open-ended wrench or socket are required for anti-tamper PRS4 regulators.
- A 12 mm open-ended wrench and a 4 mm hex drive are required for anti-tamper PRS8 regulators.

### Points of Attention Before Operation



#### CAUTION

The product can be hot or cold, depending on the environmental temperature and the process media temperature. Take the necessary precautions before operating or touching the product.

- Stopping flow through the regulator by closing a downstream shutoff valve may result in a rise in outlet pressure above the set pressure. This is usually referred to as “**lock-up**”. This phenomenon does not indicate a problem with the regulator.
- A decrease of the flow rate may result in a rise of the outlet pressure. An increase of the flow rate may result in a fall of the outlet pressure. This is usually referred to as “**droop**”. This phenomenon does not indicate a problem with the regulator.
- A decrease of the inlet pressure may result in a rise of the outlet pressure. An increase of the inlet pressure may result in a fall of the outlet pressure. This is usually referred to as “**inlet dependency**” or “**Supply Pressure Effect (SPE)**”. This phenomenon does not indicate a problem with the regulator.

### Adjusting the Set Pressure

- The set pressure is the desired outlet pressure of the regulator.
  - To set the regulator, ensure that the supply pressure is greater than the required set pressure but does not exceed the maximum rating of the regulator.
  - The regulator must be able to flow in order for it to reduce the outlet pressure.
1. Partially open any downstream valve. This will allow minimal flow through the regulator when adjusting the set pressure, reducing media consumption during this process.
  2. Fully unwind the adjustment knob counterclockwise.
  3. Steadily open the supply valve to allow inlet pressure to the regulator.
  4. To operate the regulator, turn the adjustment knob clockwise to increase the set pressure. Turn the knob counterclockwise to reduce the set pressure.
  5. To obtain the most accurate set pressure, final adjustment must be made while **increasing** the set pressure. If the desired outlet pressure is exceeded, reduce the pressure below this value then increase up to it.
  6. Fully open the downstream valve to allow full flow during operation.
  7. Once under flow conditions make any final set pressure adjustments per steps 3 and 4 if required.

## Maintenance









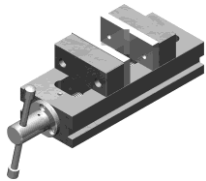

### WARNING

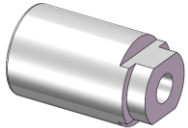
Incorrect or improper repair or servicing of this product can cause serious personal injury and property damage.

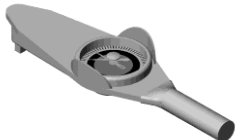
- All repairs, servicing, and testing of this product must be performed by competent personnel.
- Following any maintenance of the regulator, it is recommended that the product be tested for operation and leakage.
- The product should be checked periodically for proper and safe operation. It is the user's sole responsibility to determine the frequency of maintenance based on the application.
- To reduce maintenance related system downtime to a minimum, either during commissioning or normal operation, Swagelok recommends having maintenance kits readily available on site. The need for maintenance kits is particularly important during the commissioning phase of a system installation due to residual assembly debris remaining in the system. Such debris can cause a seat leak in the regulator, resulting in components needing to be replaced.

### Required Tools for Maintenance

Smooth-jawed vise		C-ring pliers <sup>②</sup>	
10 mm socket <sup>①</sup>		Seat retainer insertion tool <sup>②</sup> : RHPS-4-SEAT-TOOL	
14 mm open-ended wrench <sup>②</sup>		Calibrated torque wrench up to 37 lbf·ft (50 N·m)	
19 mm open-ended wrench <sup>①</sup>			
25 mm crows foot <sup>①</sup>		Lubricant (included in kit): Krytox <sup>®</sup> 240 AC	
36 mm crows foot <sup>②</sup>		Adhesive (not included in kit): Loctite <sup>®</sup> 5045, 4052 or 243	
45 mm crows foot <sup>①</sup>			
5 mm hex drive <sup>②</sup>		Liquid leak detector	

① PRS8 series only

② PRS4 series only

Table 1

## Points of Attention Before Removal from the System

- Swagelok recommends removing the regulator from the system for servicing and maintenance.
- Follow all local system safety and maintenance procedures when removing the regulator.



### WARNING

Before removing a regulator from the system, to avoid personal injury, you must:

- Depressurize the system.
- Purge the system to remove any residual system media left in the regulator.
- Always vent to a safe environment away from people and ensure there is adequate ventilation.



### CAUTION

Check if the process media is hazardous or toxic. If required, take the necessary safety precautions to ensure a safe workspace and your personal safety.



### CAUTION

The product can be hot or cold, depending on the environmental temperature and the process media temperature. Take the necessary precautions before operating or touching the product.

## Removal from the System

1. Isolate the regulator from all pressure sources by closing all appropriate upstream valves in the system.
2. With the regulator set, open all appropriate downstream valves to allow pressure to vent from the regulator.



### WARNING

Ensure all pressure on the inlet and outlet has been fully vented. The accidental release of residual trapped pressure can cause serious personal injury.

3. Disconnect and remove the regulator from the system.



## Assembly Reference Data

Item	Component Name	Kit Type(s)	Torque lbf-ft (N·m)	Recommended Lubrication (included in kit per Table 1)
1	Body	N/A		
2	Diaphragm O-ring	B1, B2, C1		
3	Poppet spring	C1, C5		
4	Poppet O-ring <sup>①</sup>	A1, A2, B1, B2, C1		Lubricate
5	Poppet	A1, A2, B1, C1		
6	Seat O-ring	A1, B1, B2, C1		
7	Seat	A1, B1, C1		
8	Seat retainer	C1	11 (15)	Lubricate threads
9	Diaphragm screw	C1	3.7 (5)	Lubricate threads
10	Diaphragm	B1, B2, C1, C3		
11	Bottom spring guide	C1		
12	Washer <sup>①</sup>	C1		
13	Hex nut <sup>①</sup>	C1	3.7 (5)	
14	Clamp ring	C1		
15	Set spring	C1, C4		
16	Spring guide	C1		Lubricate central recess
17	Ball <sup>①</sup>	C1		Lubricate
18	Spring housing	N/A	37 (50)	Lubricate threads
19	C-ring	D1		
20	Knob assembly	D1		Lubricate threads
21	Spring housing cover <sup>②</sup>	N/A		Adhesive on external threads
22	Lock nut	D1		
23	Anti-tamper set screw	D1		Lubricate threads
24	Anti-tamper cover	D1		Lubricate threads
25	Anti-tamper cover O-ring <sup>①</sup>	B1, B2, C1, D1		

① PRS8 series only

② PRS4 series, anti-tamper option only

Table 2

For more information on RHPS series maintenance kits, refer to the *Sanitary Pressure Regulators, RHPS Series* catalog, MS-02-436.

PRS4 Series, Exploded View

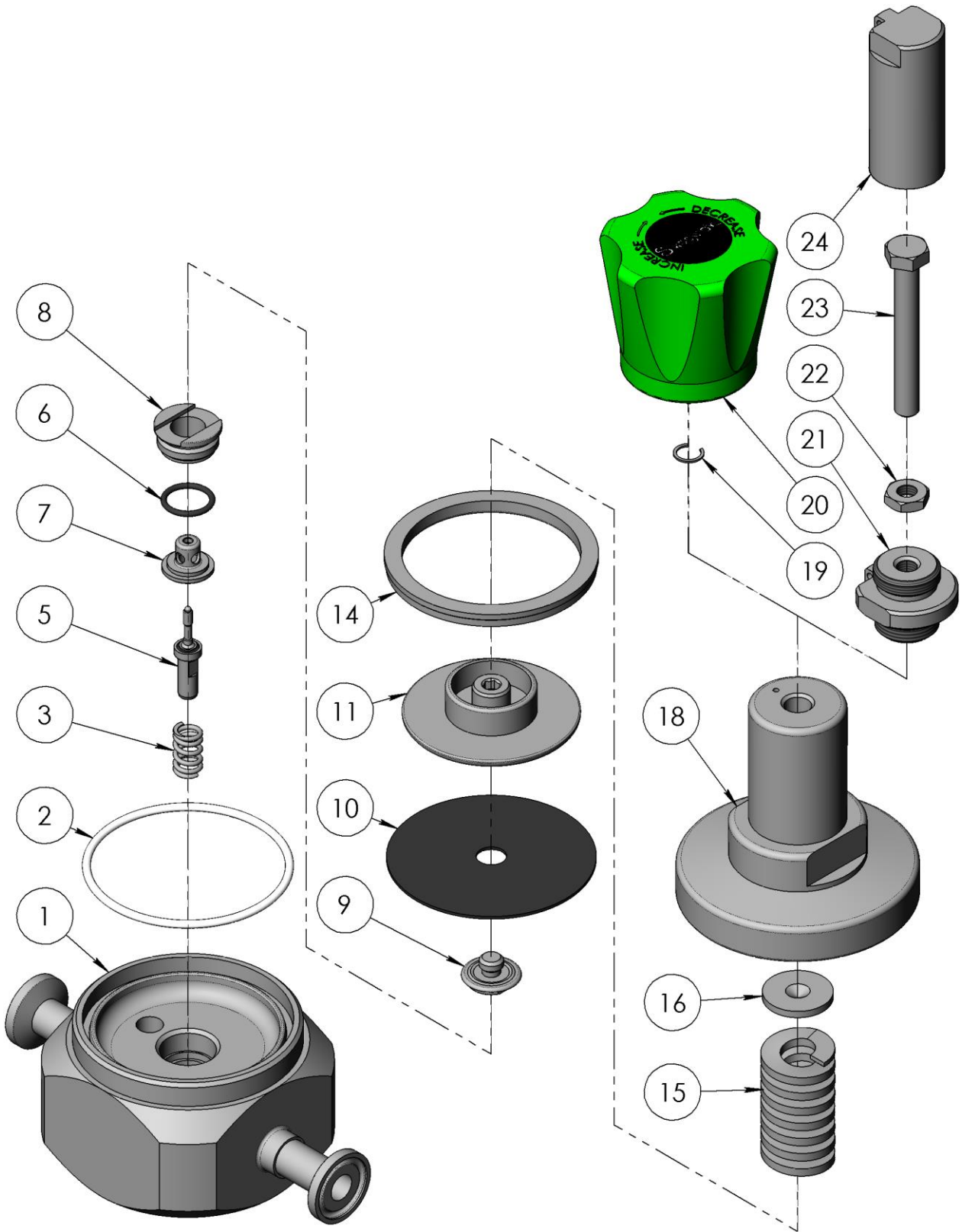

Fig 1

PRS4 Series, Section View

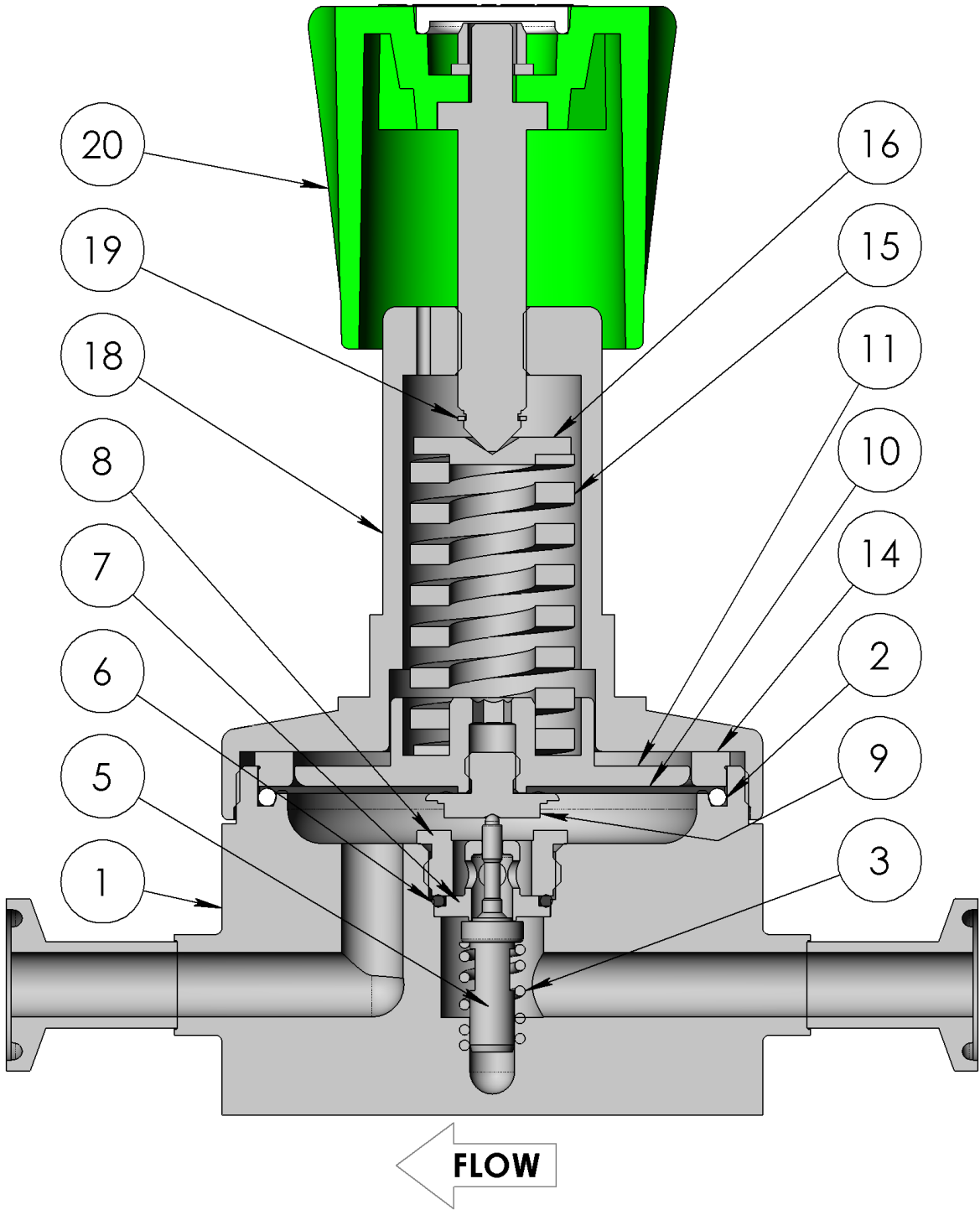

Fig 2

PRS8 Series, Exploded View

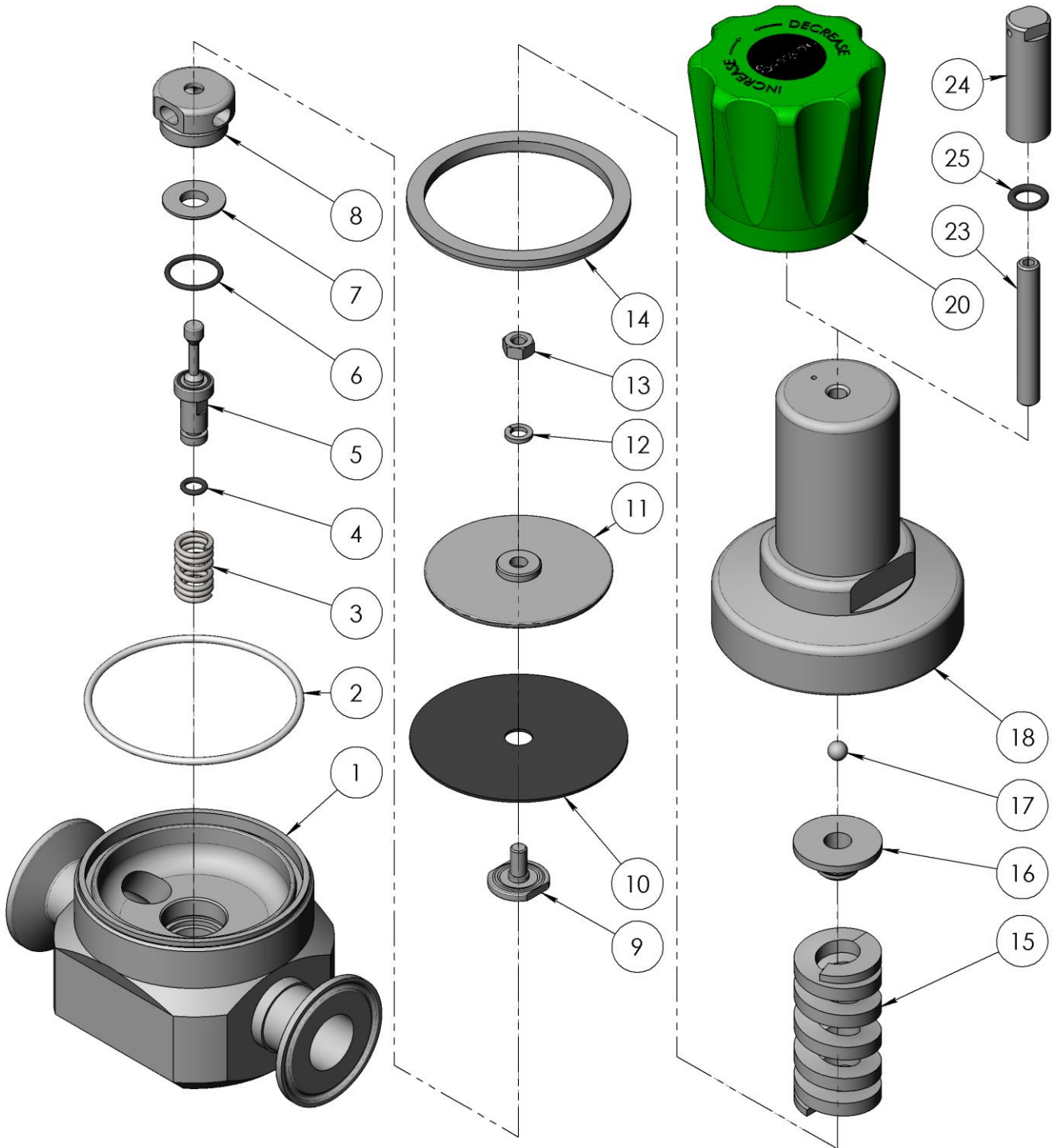

Fig 3

PRS8 Series, Section View

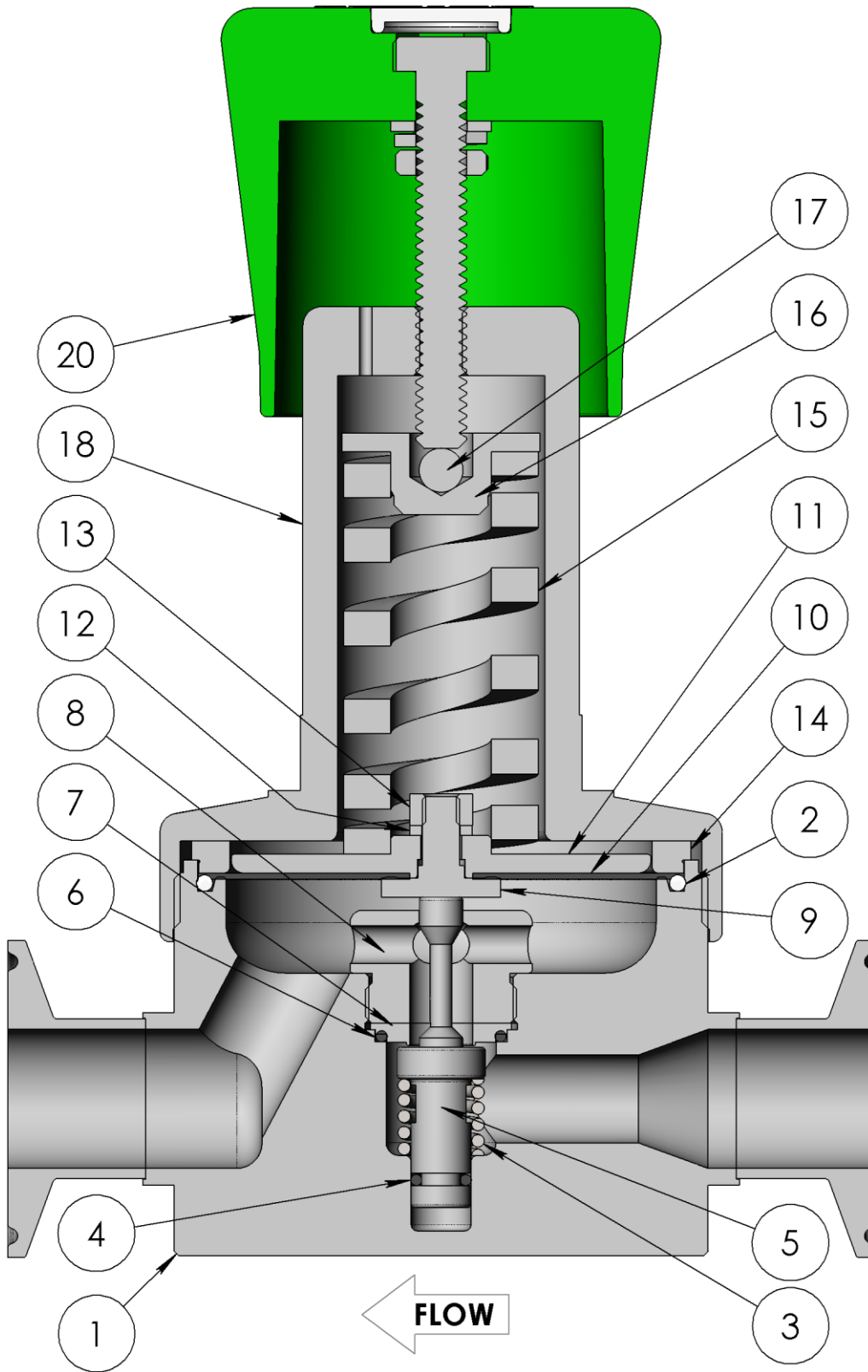

Fig 4

## Disassembly

- The following instructions describe how to fully disassemble the regulator for the purposes of maintenance and repair.
  - Note that not all components listed appear in all regulator configurations.
  - Only disassemble the regulator as far as is required to replace the components supplied in the maintenance kit.
  - Discard all components being replaced.
1. Ensure the knob assembly (20) is backed out and not acting on the set spring (15). For PRS8 series regulators it can be fully removed, if required, by unwinding counterclockwise until it detaches from the spring housing (18).
  2. Loosen the spring housing (18).
  3. Remove the spring guide (16) and set spring (15).
  4. Remove the clamp ring (14), diaphragm assembly, and diaphragm O-ring (2).
  5. To remove the diaphragm (10) unscrew the diaphragm screw (9) from the bottom spring guide (11).
  - 6a. PRS4 series: Remove the seat retainer (8) using the seat retainer insertion tool. Remove the seat (7), seat O-ring (6), poppet (5), and poppet spring (3) from the body (1).
  - 6b. PRS8 series: Remove the seat retainer (8). Remove the seat (7), seat O-ring (6), poppet (5), and poppet spring (3) from the body (1). Remove the poppet O-ring (4) from the poppet (5).
  7. PRS4 series: To remove the knob assembly (20) remove the C-ring (19) then fully unwind the knob from the spring housing (18).

## Points of Attention Before Reassembly

- Visually inspect all components for abnormal wear or damage. Replace components in case of doubt.
- All parts must remain clean and undamaged before starting assembly.
- Maintenance kit components will be supplied preassembled where practicable to aid reassembly.
- Swagelok recommends replacing all O-rings removed during disassembly.
- Swagelok recommends that dynamic O-rings should be lightly lubricated per Table 2.



### NOTICE

**All threaded components must be lightly lubricated per Table 2 before reassembly to avoid galling of threads.**

## Reassembly

### PRS4 Series

1. Secure the body (1) in a vise.
2. Insert the poppet spring (3), poppet (5), seat (7), and seat O-ring (6) into the body (1).
3. Lightly lubricate the seat retainer threads (8) and install into the body (1) using the seat retainer insertion tool. Torque to 11 lbf·ft (15 N·m).
4. Lightly lubricate the diaphragm screw threads (9). Fit the diaphragm (10) onto the diaphragm screw (9) then screw this into the bottom spring guide (11). Torque to 3.5 lbf·ft (5 N·m).
5. Fit the diaphragm O-ring (2) into the body (1).
6. Insert the sensing assembly into the body (1).
7. Fit the clamp ring (14) into the body (1) on top of the diaphragm (10). Orient per Fig 2.
8. Lightly lubricate the knob assembly stem (20) and thread it through the spring housing (18).
9. Secure the C-ring (19) onto the groove at the end of the stem (20).
10. Lubricate the recess of the spring guide (16).
11. Stack the set spring (15) and spring guide (16) onto the bottom spring guide (11).
12. Lightly lubricate the spring housing threads (18) and screw it onto the body (1). Torque to 37 lbf·ft (50 N·m).

### PRS8 Series

1. Secure the body (1) in a vise.
2. Fit the poppet O-ring (4) onto the poppet (5).
3. Insert the poppet spring (3), poppet (5), seat (7), and seat O-ring (6) into the body (1).
4. Lightly lubricate the seat retainer threads (8) and install into the body (1). Torque to 11 lbf·ft (15 N·m).
5. Lightly lubricate the diaphragm screw threads (9). Fit the diaphragm (10) onto the diaphragm screw (9) then fit the bottom spring guide (11), washer (12), and nut (13). Torque to 3.5 lbf·ft (5 N·m).
6. Fit the diaphragm O-ring (2) into the body (1).
7. Insert the sensing assembly into the body (1).
8. Fit the clamp ring (14) into the body (1) on top of the diaphragm (10). Orient per Fig 4.
9. Lightly lubricate the knob assembly stem (20) and thread it through the spring housing (18).
10. Fit the ball (17) into the spring guide (16) and retain in place with lubricant.
11. Stack the set spring (15) and spring guide (16) onto the bottom spring guide (11).
12. Lightly lubricate the spring housing threads (18) and screw it onto the body (1). Torque to 37 lbf·ft (50 N·m).

## Testing

Swagelok recommends that the regulator be tested for seat and shell leakage to atmosphere. A well performing regulator will not show any indication of leaking. If any evidence of a leak is identified this must be rectified. Any damaged components must be replaced.

### Seat Leak Test

1. Ensure there is sufficient supply pressure to the regulator to be able to perform the tests.
2. Ensure the handle is screwed fully counterclockwise.
3. Maintain an inlet pressure of approximately 14.5 psig (1 bar) on the regulator and close the downstream shutoff valve.
4. Monitor the outlet pressure. An increase in pressure over time indicates a seat leak.
5. Repeat the procedure with the highest inlet pressure applicable for the regulator and system.

### Shell Leak Test

1. Maintain an inlet pressure of approximately 29 psig (2 bar) on the regulator and close the downstream shutoff valve.
2. Increase the outlet pressure to approximately 14.5 psig (1 bar).
3. Using liquid leak detector, check for bubbles at the spring housing to body interface and the spring housing weep hole.
4. Repeat the procedure with the highest inlet and outlet pressure applicable for the regulator and system.



## Troubleshooting

Symptom	Cause	Remedy
The outlet pressure creeps up, without adjusting the spring.	A damaged poppet and/or seat.	Replace the poppet and/or seat.
Leakage between the body and the spring housing or through the spring housing weep hole.	A damaged diaphragm or O-ring.	Replace the diaphragm or O-ring.
	Insufficient torque on the spring housing.	Tighten the spring housing per Table 2.
Controlled pressure drops off sharply even when the flow is within regulator capabilities.	The system filter element is clogged.	Replace the system filter.
The required outlet pressure cannot be reached.	The inlet pressure to the regulator is not high enough.	Ensure that the inlet pressure to the regulator is equal to or greater than the desired set pressure.
The outlet pressure rises too much when going from a dynamic to a static situation.	There is too much flow in the dynamic situation.	A larger regulator or parallel regulator is required. Review application flow capacity and contact your local authorized sales and service center.
The outlet pressure does not drop when the knob is adjusted counterclockwise.	The regulator is non-venting.	A shutoff valve in the outlet line must be opened to reduce the outlet pressure.
The outlet pressure has changed without adjusting the handle.	Changes to the inlet pressure may result in changes to the outlet pressure.	Maintain a constant inlet pressure to the regulator. See “ <b>Points of Attention Before Operation</b> ” about <b>dependency</b> .
	Changes to the flow may result in changes to the outlet pressure.	Maintain a constant flow through the regulator. See “ <b>Points of Attention Before Operation</b> ” about <b>droop</b> .

Table 3





## Warranty Information

Swagelok products are backed by The Swagelok Limited Lifetime Warranty.  
For a copy, visit [swagelok.com](http://swagelok.com) or contact your authorized Swagelok representative.

Swagelok, Snoop - TM Swagelok Company  
Loctite — TM Henkel Corp.  
Krytox – TM The Chemours Company  
© 2018 Swagelok Company  
July 2018, RevB  
MS-CRD-0172

The Swagelok logo is written in a blue, stylized, cursive font. The letters are connected, and the 'S' is particularly large and prominent.