

RL4 Series Low Pressure Relief Valve

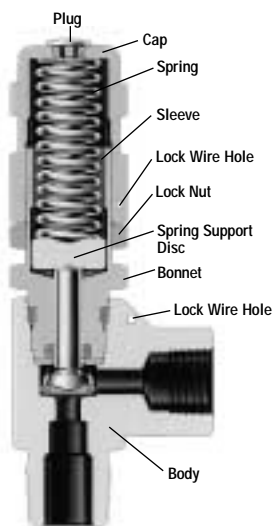

Adjusting the Set Pressure

*Note: Adjust the set pressure **before** installing the valve in a system.*

1. Thread **cap** onto the **bonnet** 10 full turns.
2. Tighten **lock nut** against the **cap** and test for pressure.
3. Relieve system pressure, unthread **cap** as needed, and retest. Repeat procedure as necessary to obtain desired set pressure.
4. Tighten **lock nut** against the **cap**.
5. Lock wire **cap** and **body** together to maintain set pressure.

Manual Override Conversion

! Warning: Relieve system pressure before installing manual override handle.

1. Loosen **lock nut** and remove **cap** from **bonnet**.
2. Remove **plug** from **cap**.
3. Remove **spring** from **bonnet**.
4. Remove **sleeve** by pulling up on base of **sleeve** with hooked tool.
5. Remove **spring support disc**.
6. Install **pull rod** into **bonnet**.
7. Install **sleeve** by compressing it with a suitable tool and pushing it down into **bonnet**.
8. Place **spring** over **pull rod**.
9. Place **cap** over **pull rod**, resting it on **bonnet**.
10. Screw **handle** onto **pull rod**. Tighten **set screw** on handle to 20 in.-lb (2.2 N-m) with 5/64 in. hex wrench.
11. Engage **cap** threads.

Proceed to "Adjusting the Set Pressure"

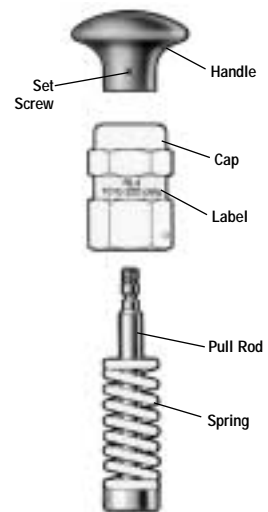

RL4 Series Low Pressure Relief Valve

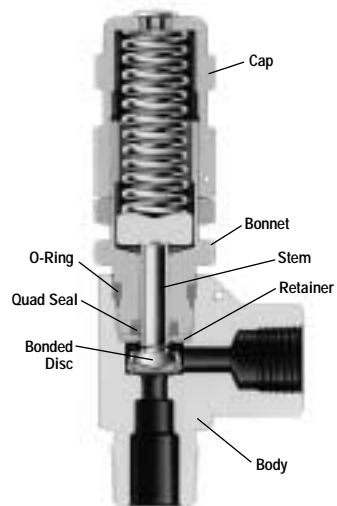

Contents:

- 1 Quad Seal
- 1 O-ring
- 1 Bonded Disc
- 1 Retainer

Stem Seal Replacement

1. Remove valve from system.
 2. Loosen **cap** to relieve spring pressure.
 3. Remove **bonnet** from **body**.
 4. Remove **retainer** and **stem** from **bonnet**.
- NOTE: Disc remains in **valve body**.
5. Remove **quad seal** from **bonnet**.
 6. Make sure all parts are clean before reassembly.
 7. Install new **quad seal** into **bonnet**. (Lubricate with system compatible lubricant.)

NOTE: If also replacing bonded disc, follow steps 4 through 6 of Bonded Disc Replacement.

8. Insert **stem** with bonded disc into **bonnet**, then place **retainer** over **stem**.
9. Remove and replace **bonnet O-ring**. (Lubricate with system compatible lubricant.)
10. Thread **bonnet** into **body** and tighten **400 in.-lb (45 N-m)**.
11. Adjust to desired set pressure as described on reverse side.
12. Install in system. Grip valve on wrench pad during installation.

Bonded Disc Replacement

1. Remove valve from system.
2. Loosen **cap** to relieve spring pressure.
3. Turn **valve** upside down and remove **body** from **bonnet**.
4. Remove **disc** from **stem**.
5. Make sure all parts are clean before reassembly.
6. Place new **disc** on stem.
7. Remove and replace **bonnet O-ring**. (Lubricate with system compatible lubricant.)
8. Thread **body** onto **bonnet** and tighten to **400 in.-lb (45 N-m)**.
9. Adjust to desired set pressure as described on reverse side.
10. Install in system. Grip valve on wrench pad during installation.

Swagelok

www.swagelok.com

These instructions are also available in French, Italian, German, and Spanish.

© 1992, 1998, 2003 Swagelok Company

Rev. C
5-03 CP
MS-CRD-0055

