

M200 Power Supply



User's Manual

This manual contains important information for the safe and effective operation of the Swagelok® Welding System M200 power supply. Users should read and understand its contents before operating the M200 power supply.

Swagelok®

Contents

Safety	5
Safety Summary	5
Signal Words and Safety Alert Symbols Used in this Manual	5
M200 Power Supply Warning Label	10
Referenced Documents	11
Installation and Setup	13
Description	14
Unpacking the M200 Power Supply	16
Registration Information	17
Tools and Accessories Required	18
Electrical Requirements	18
Setting up the M200 Power Supply	19
Installing the Weld Head	20
Setting Up the Gas Supply System	21
Typical OD Shield / ID Purge Gas Supply System	21
Powering On the M200 Power Supply for the First Time	22
Powering Off the M200 Power Supply	22
Restarting the M200 Power Supply	22
Using the Touch Screen	23
User Interface	23
Operation	25
Main Menu	25
Weld Screens	28
Performing a Weld	34
File Screens	35
Program Screens	38
Weld Log Screens	39
Setup Screens	42
Ethernet Instructions	43
Remote Pendant	49
Maintenance	50
Printer	51
Changing Paper	51
Installing and Replacing the Optional Fan Filter	53
Weld Parameter Development	54
Weld Parameter Changes	55
Creating a Weld Procedure Guideline	55
Weld Procedure Guideline Worksheets	56

Advanced Weld Procedure Techniques	66
Tacks	67
Ramp Time	68
Ramping Up in Level 1	69
Added Rotor Delay Time Before Welding	71
Step Programs for Multilevel Weld Procedures	73
Weld Parameter Guideline Worksheet Reference Data	82
Single Level Mode Operation	86
Single Level Current-Control Group	87
Single Level Timing-Control Group	87
Single Level Weld Process Buttons	88
Single Level Status Indicator Lights	89
Single Level Weld Status Conditions	89
Single Level Weld Procedure Guidelines	90
Evaluating Weld Quality	98
Identifying Proper Welds	98
Identifying Typical Weld Discontinuities	98
Improper Welds	99
No ID Penetration	99
Increased ID Convexity and Weld Bead Width	100
Weld-Puddle Overlap	100
Specifications	101
M200 Power Supply Output and Duty Cycle	101
M200 Power Supply with 115 V Input	101
M200 Power Supply Cycle Times	102
M200 Power Supply Dimensions	102
Use of Extension Cords with the M200 Power Supply	102
Troubleshooting	103
Weld Status Conditions	103
Disable	103
Operational	105
Weld Errors	107
Weld System Hardware and Weld Process Problems	109
Power Supply Repair	117
Glossary	118
Swagelok Embedded System End User License Agreement	122
The Swagelok Limited Lifetime Warranty	124

Safety

Safety Summary

Arc welding can be hazardous.



Read the entire safety information section and M200 Power Supply User's Manual before using this product. Failure to do so can result in serious injury or death.

Signal Words and Safety Alert Symbols Used in this Manual

WARNING Statements that indicate a hazardous situation which, if not avoided, could result in death or serious injury.

CAUTION Statements that indicate a hazardous situation which, if not avoided, could result in minor or moderate injury.

NOTICE Statements that indicate a hazardous situation which, if not avoided, could result in damage to the equipment or other property.



Safety alert symbol indicating a potential personal injury hazard.



Safety alert symbol indicating a potential for personal injury from electrical shock.



Safety alert symbol indicating a potential for personal injury from exposure to fumes and gases.



Safety alert symbol indicating a potential for personal injury from exposure to the weld arc.



Safety alert symbol indicating a potential for personal injury resulting from a welding related fire or explosion.



Safety alert symbol indicating a potential for personal injury resulting from a welding related cylinder explosion.

**WARNING**

Orbital gas tungsten arc welding (GTAW) can be hazardous. Only qualified persons should use this equipment.

After welding, the work piece, weld head, electrode, fixture block, and collets can be extremely hot and may cause burns.

Keep children away.

Pacemaker wearers should consult with their physician before operating this equipment.

Read and understand ANSI Standard Z49.1, "Safety in Welding and Cutting," from the American Welding Society and OSHA Safety and Health Standards, 29 CFR 1910 and 1926, from the U.S. Government Printing Office.

The M200 power supply has no internal serviceable parts and should not be disassembled. Return the M200 power supply to an authorized Swagelok sales and service representative for service.

***ELECTRIC SHOCK can kill.***

Touching live electrical parts and failure to operate equipment properly can cause fatal electric shock and severe burns. Incorrectly installed or improperly grounded equipment is a hazard. To avoid injury:

- Do not touch live electrical parts.
- Keep all panels and covers securely in place. Do not touch electrode connector, electrode, or rotor after pressing start. The electrode is electrically charged during the weld process.
- Follow local electrical codes and the guidelines in this manual when installing the M200 power supply. Shock hazards can exist even when equipment is properly installed, so it is important that the operator be trained in the proper use of the equipment and follow established safety practices.
- Frequently inspect input power cord for damage or bare wiring—replace immediately if damaged.
- Properly unplug the power cord. Grasp the plug to remove it from the receptacle.

**FUMES AND GASES can be hazardous.**

Welding produces fumes and gases. Breathing these fumes and gases may be hazardous to your health. Build-up of gases can displace oxygen and cause injury or death. To avoid injury:

- Do not breathe fumes or gases.
- Ventilate the area and/or use exhaust at the arc to remove welding fumes and gases.
- When welding materials that produce toxic fumes, such as galvanized steel, lead, cadmium-plated steel or other coated metals (unless the coating is removed from the weld area), or any other welding material, keep exposure below threshold limit values (TLV), permissible exposure limits (PEL), or other applicable health and safety limitation. If necessary, wear a respirator. Read and understand the Material Safety Data Sheets (MSDS) and follow the manufacturer's instructions for metals, consumables, coatings, cleaners, degreasers, or any other substance that may be present during the weld process.
- Do not work in a confined space unless it is well ventilated or you are wearing an air-supplied respirator. Always have a trained watch-person nearby. Welding fumes and gases can displace air and lower the oxygen level causing injury or death. Be sure the breathing air is safe.
- Do not weld in locations near degreasing, cleaning, or spraying operations. The heat and rays of the arc can react with vapors to form highly toxic and irritating gases.
- The ultraviolet light emitted by the welding arc acts on the oxygen in the surrounding atmosphere to produce ozone. Test results^①, based upon present sampling methods, indicate the average concentration of ozone generated in GTAW process does not constitute a hazard under conditions of good ventilation and welding practice.
- Shut off gas supply when not in use.

^① *Welding Handbook*, Vol 2, 8th ed., American Welding Society.



ARC RAYS can burn eyes.



Arc rays from the welding process produce intense visible and invisible (ultraviolet and infrared) rays that can burn eyes. The M200 power supply is meant for use only with enclosed Swagelok weld heads, which minimize exposure to these harmful rays. To avoid injury:

- Do not look at welding arc.
- Use protective screens or barriers to protect others from flash and glare; warn others not to watch the arc.
- Wear personal protective equipment, including eye protection.



WELDING can cause fire or explosion.

Welding on closed containers, such as tanks, drums, or pipes, can cause them to explode. The hot work piece and hot equipment can cause fires and burns. Ensure the area is free of combustibles before welding. To avoid injury:

- Do not place the M200 power supply over a combustible surface. See the label on the bottom of the M200 power supply (Fig. 1).
- Do not weld in a combustible environment.
- Watch for fire, and keep a fire extinguisher nearby.
- Do not weld on closed containers such as tanks, drums, or pipes, unless they are properly prepared in accordance with AWS F4.1.
- Do not use the M200 power supply to thaw frozen pipes.
- Do not use extension cords that are in poor physical condition or have insufficient current capacity. Failure to do so can pose fire and shock hazards.
- Sparks and spatter are thrown from the weld arc. The M200 power supply is meant for use with enclosed weld heads, which minimizes exposure to spatter. Wear proper protective equipment, including eye protection.

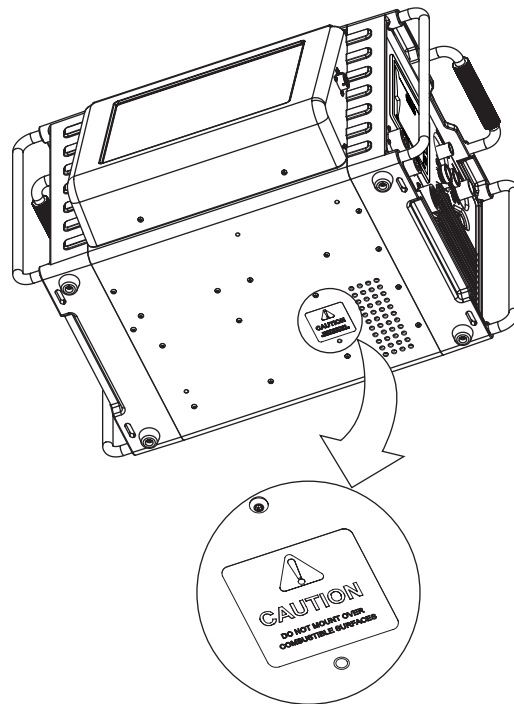

Fig. 1—M200 Power Supply Mounting Caution Label









CYLINDERS may explode if damaged.

Gas cylinders used as part of the orbital GTAW process contain gas under high pressure. If damaged, a cylinder can explode. To avoid injury:

- Protect compressed gas cylinders from excessive heat, mechanical shocks, slag, open flames, sparks, and arcs. Follow all site safety precautions and protocol.
- Install cylinders in an upright position by securing to a stationary support or cylinder rack to prevent falling or tipping.
- Keep cylinders away from any welding or other electrical circuits.
- Never weld on a pressurized cylinder—explosion will result.
- Use only correct shielding gas cylinders, regulators, hoses, and fittings designed for the specific application; maintain them and associated parts in good condition.
- Keep head and face away from valve outlet when opening cylinder valve.
- Keep valve protective cap in place over valve except when cylinder is in use or connected for use.
- Read and follow instructions on compressed gas cylinders, associated equipment, and CGA publication P-1 listed in **Referenced Documents**, page 11.

M200 Power Supply Warning Label

This warning label must remain affixed to the top of the power supply (Fig. 2).

 WARNING		ARC WELDING can be hazardous. <ul style="list-style-type: none"> • Read and follow this label and the User's Manual. • Only qualified persons are to install and operate this unit. • Keep children away. • Pacemaker wearers keep away. • Return to authorized sales and service center for service. 	
Do Not Remove, Destroy, or Cover This Label For user information contact Swagelok Co. (www.Swagelok.com)			
	ELECTRIC SHOCK can kill. <ul style="list-style-type: none"> • Do not touch live electrical parts. • Electrode and rotor are live during weld cycle. • Keep all panels and covers securely in place. 		WELDING can cause fire or explosion. <ul style="list-style-type: none"> • Do not weld on closed containers. • Do not use in a combustible environment or over a combustible surface.
	FUMES AND GASES can be hazardous. <ul style="list-style-type: none"> • Do not breathe fumes or gases. • Use ventilation or exhaust to remove fumes from breathing zone. • Read Material Safety Data Sheets (MSDS's) and follow manufacturer's instructions for the material used. 		ARC RAYS can burn eyes. <ul style="list-style-type: none"> • Do not look at welding arc. • Wear personal protective equipment including eye and ear protection.
Read American National Standard Z49.1, "Safety in Welding and Cutting," from American Welding Society, 550 N.W. LeJeune Rd., Miami, FL 33126; OSHA Safety and Health Standards, 29 CFR 1910 and 1926, from U.S. Government Printing Office, P.O. Box 371954, Pittsburgh, PA 15250			
	 AVERTISSEMENT		LE SOUDAGE A L'ARC peut être dangereux. <ul style="list-style-type: none"> • Lisez et respectez cette étiquette ainsi que le manuel utilisateur. • Ne pas utiliser dans un environnement combustible ou au dessus d'une surface combustible. • Ne touchez pas les parties électriques sous tension. • L'électrode et le rotor sont sous tension pendant le soudage.

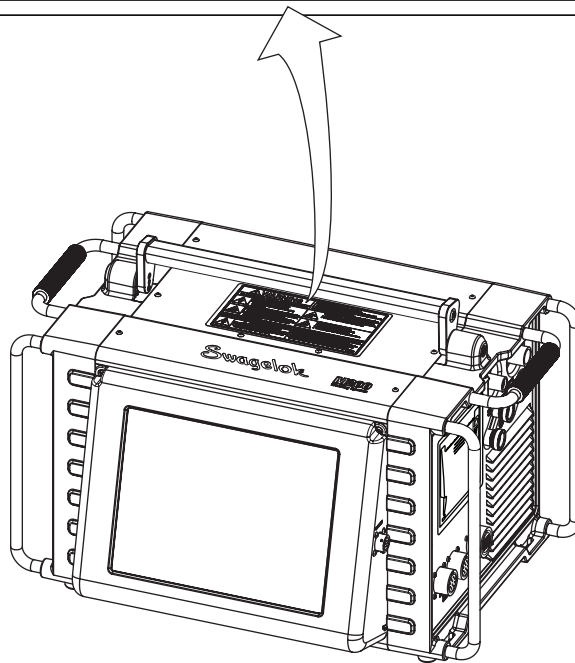

Fig. 2—M200 Power Supply Warning Label

Referenced Documents

- 1. AWS F4.1, *Recommended Safe Practices for the Preparation for Welding and Cutting of Containers and Piping.***
American Welding Society, 550 N.W. LeJeune Rd, Miami, FL 33126 (www.aws.org).
- 2. ANSI Z49.1, *Safety in Welding Cutting, and Allied Processes.***
American Welding Society, 550 N.W. LeJeune Rd, Miami, FL 33126 (www.aws.org).
- 3. CGA Publication P-1, *Safe Handling of Compressed Gases in Cylinders.***
Compressed Gas Association, 4221 Walney Road, 5th Floor, Chantilly VA 20151-2923, (www.cganet.com).
- 4. OSHA 29CFR 1910 Subpart Q, *Welding Cutting, and Brazing.***
Acquire from U.S. Government Printing Office, Superintendent of Documents, P.O. Box 371954, Pittsburgh, PA 15250 (www.osha.gov).
- 5. OSHA 29CFR 1926 Subpart J, *Welding and Cutting.***
Acquire from U.S. Government Printing Office, Superintendent of Documents, P.O. Box 371954, Pittsburgh, PA 15250 (www.osha.gov).

Installation and Setup

Description

The Swagelok Welding System M200 power supply provides precise control of weld current, electrode travel speed, and OD shield gas flow to produce consistent and repeatable weld results.

The unit features a touch-screen display for easy navigation and data input. To access menus and input weld data, the operator presses the touch screen over the selection. In the Single Level Mode, users can enter data using simulated thumb wheels.

Four USB A version 1.1 ports on the side of the M200 power supply accept compatible USB hardware, such as a USB mouse or keyboard, with no additional software required. A USB flash drive (not supplied) provides portable memory and can be used to transfer data to other M200 power supply units and/or a PC. A 1 GB USB flash drive is recommended. There are additional ports for video SVGA output and a serial cable for direct PC connection.

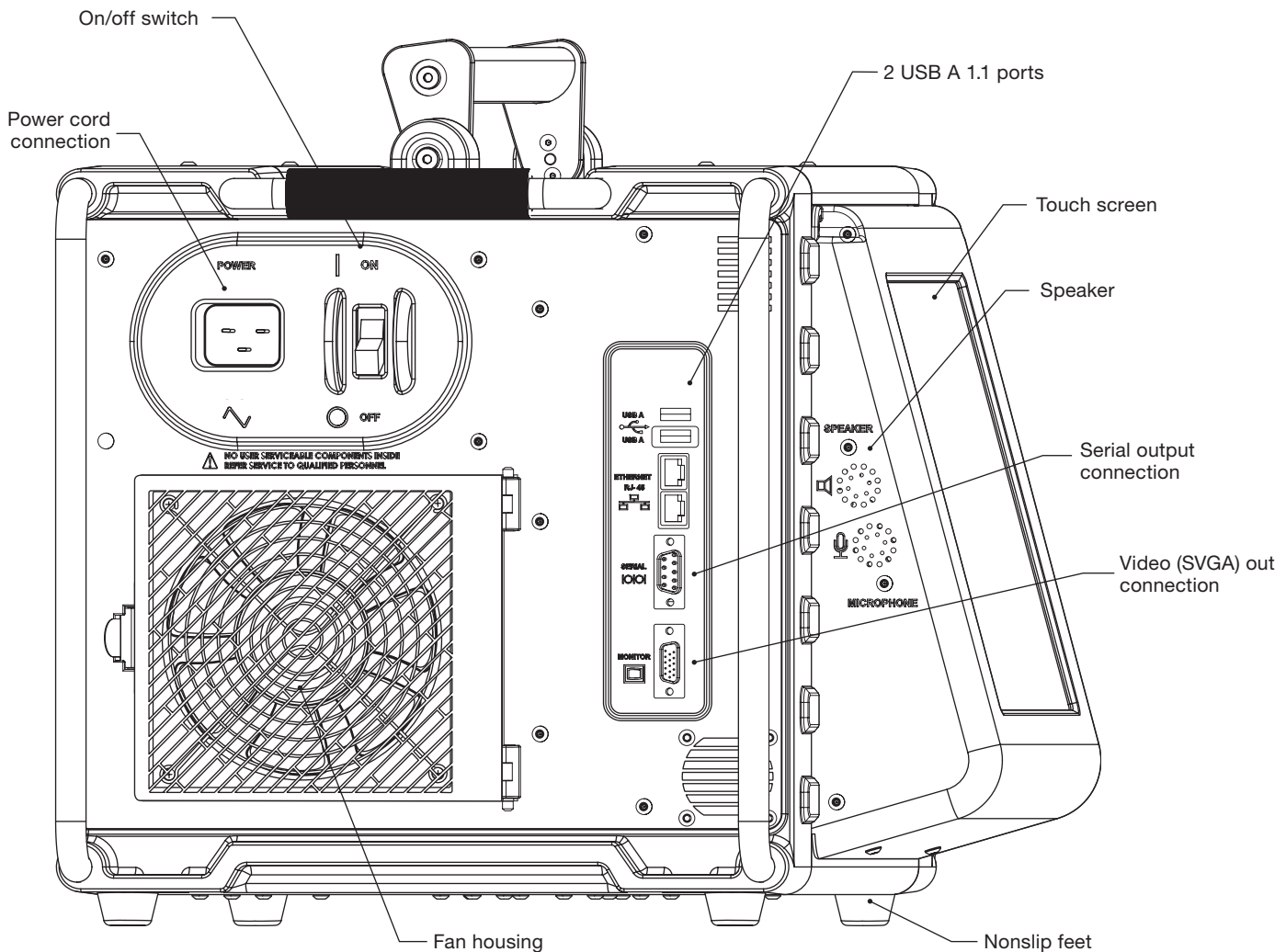

Fig. 3—M200 Power Supply Left Side

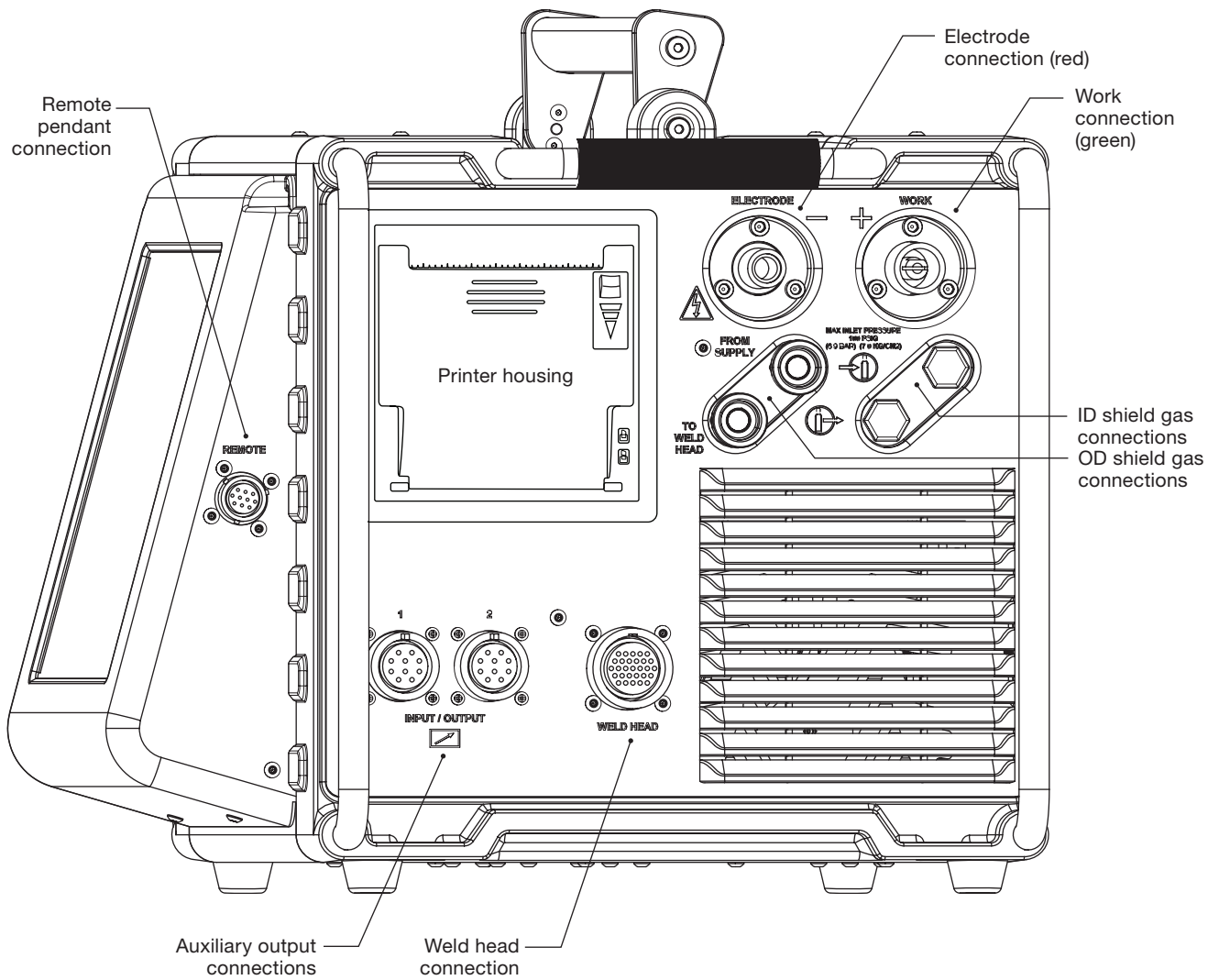

Fig. 4—M200 Power Supply Right Side

Unpacking the M200 Power Supply

Table 1—Shipping Case Contents

Description	Ordering Number	Qty
M200 power supply	SWS-M200-XX-Y <i>-XX denotes power cord plug type</i> <i>-Y denotes user's manual language</i>	1
Power cord	CWS-CORD-X <i>-X denotes power cord plug type</i>	1
1/4 in. male Quick-Connect stem	SS-QC4-S-400	1
<i>M200 Power Supply User's Manual</i>	MS-13-212-Y <i>-Y denotes user's manual language other than English</i>	1
Warranty Information Form	—	1

Note: Contact your authorized Swagelok representative if the unit is damaged.

Remove the contents of the shipping case (Table 1):

1. Use the handle on the top of the M200 power supply to lift it out of the case. Place the M200 power supply upright on a stable surface.
2. Check the M200 power supply and accessories for damage.
3. Record the model number and serial number from the rating label on the back of the M200 power supply (Fig. 5), along with the delivery date, on the M200 Power Supply Warranty Information form and the Registration Information form, page 17. Return the Warranty Information form to your authorized Swagelok representative to activate the warranty.

Note: Do not store the M200 power supply near corrosive materials. Store indoors and cover when not in use.

Registration Information

Your authorized Swagelok representative provides support and service for your M200 power supply and Swagelok weld heads.

Please take a moment to fill out the information listed below. See the rating label on the back of the M200 power supply (Fig. 5) for the model and serial numbers.

Keep this information available in case you need to contact your authorized Swagelok representative.

Date of Delivery: _____

Power Supply Model Number: _____
 Serial Number: _____

Weld Head Model Number: _____
 Serial Number: _____

Weld Head Model Number: _____
 Serial Number: _____

Weld Head Model Number: _____
 Serial Number: _____

Weld Head Model Number: _____
 Serial Number: _____

Company Name: _____

Swagelok Distributorship: _____

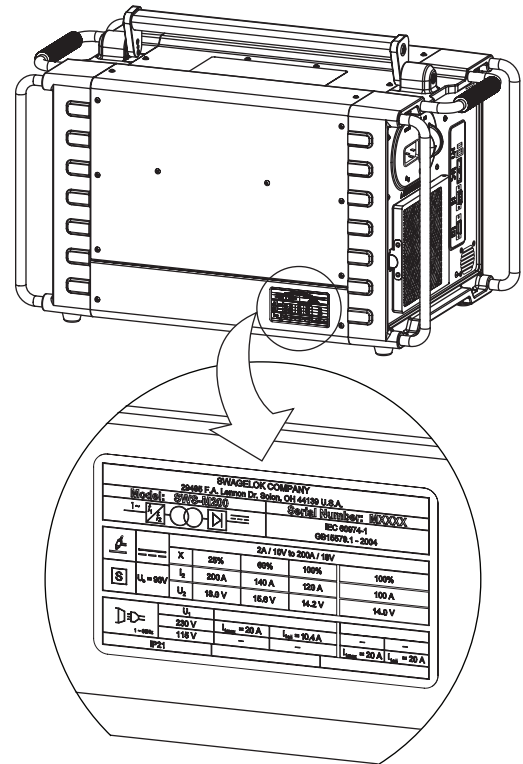

Fig. 5—M200 Power Supply Rating Label

Tools and Accessories Required

Table 2—Tools and Accessories

Tool/Accessory	Included-	Provided With
Hex wrenches (1/2 to 5/32 in.)	Yes	Weld head
Electrode package	Yes ^①	Weld head
Arc gap gauge	Yes ^①	Weld head
Flat-blade screw driver	Yes	Weld head
Centering gauge	Yes ^①	Fixture block
Calipers or micrometer	No	—
Purge kit (Ordering number: SWS-PURGE-KIT)	No	—
Low-moisture gas lines	No	—
Gas source	No	—
Pressure regulator	No	—
ID purge gas flow meter	No	—
Pressure gauge	No	—

^① The Series 40 weld head does not include an electrode, arc gap gauge, or centering gauge package.

Electrical Requirements

M200 Power Supply Installation

All user-supplied wiring and related components must be installed in accordance with local electrical codes. A dedicated electrical circuit may be required to maintain optimum current levels. If input voltage is 100 V or less, output power capabilities may be reduced.



WARNING

The M200 power supply must be grounded or electrical shock can result.

Table 3—Voltage and Current Requirements

Power Supply Model	Voltage Requirement	Service Current
M200	100 V (ac)	20 A
	230 V (ac)	16 A

See **Specifications**, page 101, for detailed power input and output information.

Using Extension Cords

Extension cords may be used with the M200 power supply. Extension cords must meet the current capacity specifications in Table 43, page 102.

Setting up the M200 Power Supply

1. Position the M200 power supply so that both sides are accessible.
2. Make sure the power switch on the left side of the M200 power supply is in the OFF (O) position.
3. Connect the power cord to the power connector on the side of the unit (Fig. 6).
4. *Optional:* Install the fan filter on the left side of the M200 power supply. See page 53.

Note: The M200 power supply should not be operated when resting on either the left or the right side (printer or fan/filter side) or when tilted more than 15° on its horizontal axis. The MFC will not function properly in these positions.

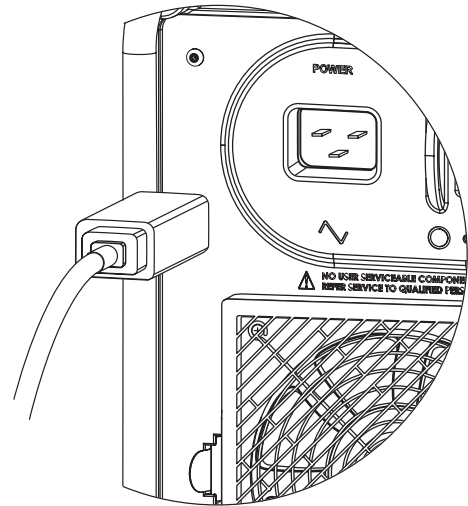

Fig. 6—Connecting the Power Cord

Installing the Weld Head

The weld head assembly attaches to the right side of the M200 power supply with four separate connectors (Fig. 7) :

- Weld head quarter-turn connector
- Electrode (red)
- Work (green)
- Weld head OD shield gas.

1. Align the notch on the weld head quarter-turn connector with the small tab in the M200 power supply socket labeled WELD HEAD (Fig. 8) and insert the connector. Turn it clockwise to lock it in place. An audible click indicates that the connection is locked. This connection provides the control signals to drive the weld head.

Note: Use the weld head adapter cable, ordered separately, if the weld head does not have a quarter-turn connection. Attach the weld head adapter cable to the end of the threaded multipin connector. Tighten the weld head adapter cable until only two or three threads are visible.

2. Insert the red connector arrow side up into the M200 power supply red socket labeled ELECTRODE. Turn the connector one-quarter turn clockwise to lock it in place. This connection is the negative (-) terminal of the weld head.
3. Insert the green connector arrow side up into the M200 power supply green socket labeled WORK. Turn the connector one-quarter turn clockwise to lock it in place. This connection is the positive (+) terminal of the weld head.
4. Insert the weld head OD shield gas Swagelok quick-connect stem into the M200 power supply fitting labeled TO WELD HEAD. This connection provides shielding gas to the weld head through the mass flow controller in the power supply.

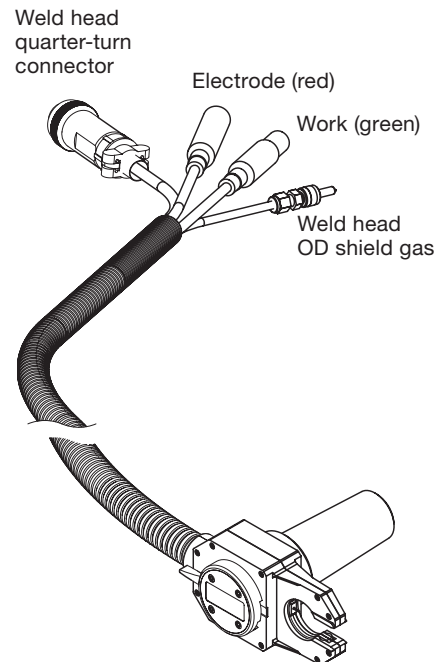

Fig. 7—Weld Head Assembly Connections

NOTICE

All connections must be fully seated and locked in place to prevent damage to connections or weld head.

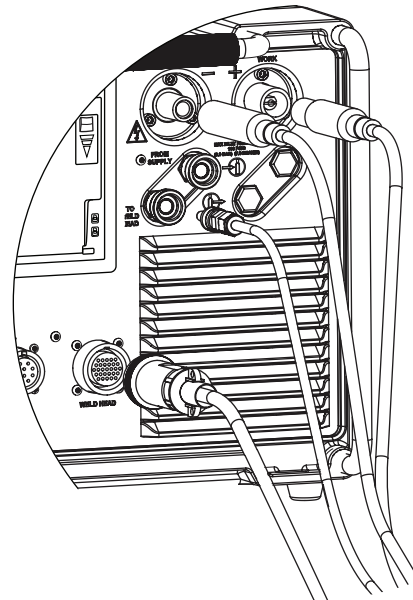

Fig. 8—Connecting the Weld Head Assembly to the Power Supply



WARNING

Do not remove the weld head from the M200 power supply while a weld is in process. Electrical shock can result.

Setting Up the Gas Supply System

The M200 power supply has an integral mass flow controller (MFC) to control and monitor the flow of the gas supply system that provides OD shield gas to the weld head. OD shield gas fills the weld chamber to protect the electrode and weld puddle from contaminating elements in the surrounding air.

ID purge gas flows within a tube or at the back of a weld joint to remove oxygen and prevent oxidation.

Typical OD Shield / ID Purge Gas Supply System

Figure 9 shows a typical gas supply system. Before setting up the gas supply system, read and understand the **Safety** section of this manual. See page 5.

1. Make sure the gas storage containers are upright and secured before use.
2. Check all connections for leaks.
3. Use only Swagelok quick-connect stems (ordering number **SS-QC4-S-400**) as gas connectors on the M200 power supply.
4. Regulate the OD shield gas pressure to obtain the desired flow rate. The typical pressure range is 45 to 50 psig (3.1 to 3.4 bar). Flow rates greater than 70 std ft³/h (33 std L/min) may require higher pressures.



CAUTION

Do not mix or interchange parts with those of other manufacturers. Personal injury or equipment damage can result.

NOTICE

Do not exceed an inlet pressure of 100 psig (6.8 bar) or MFC can be damaged.

NOTICE

The MFC is not a shutoff device. There may be gas flow of up to 1/2 std ft³/h (0.24 std L/min) when the shield gas is off.

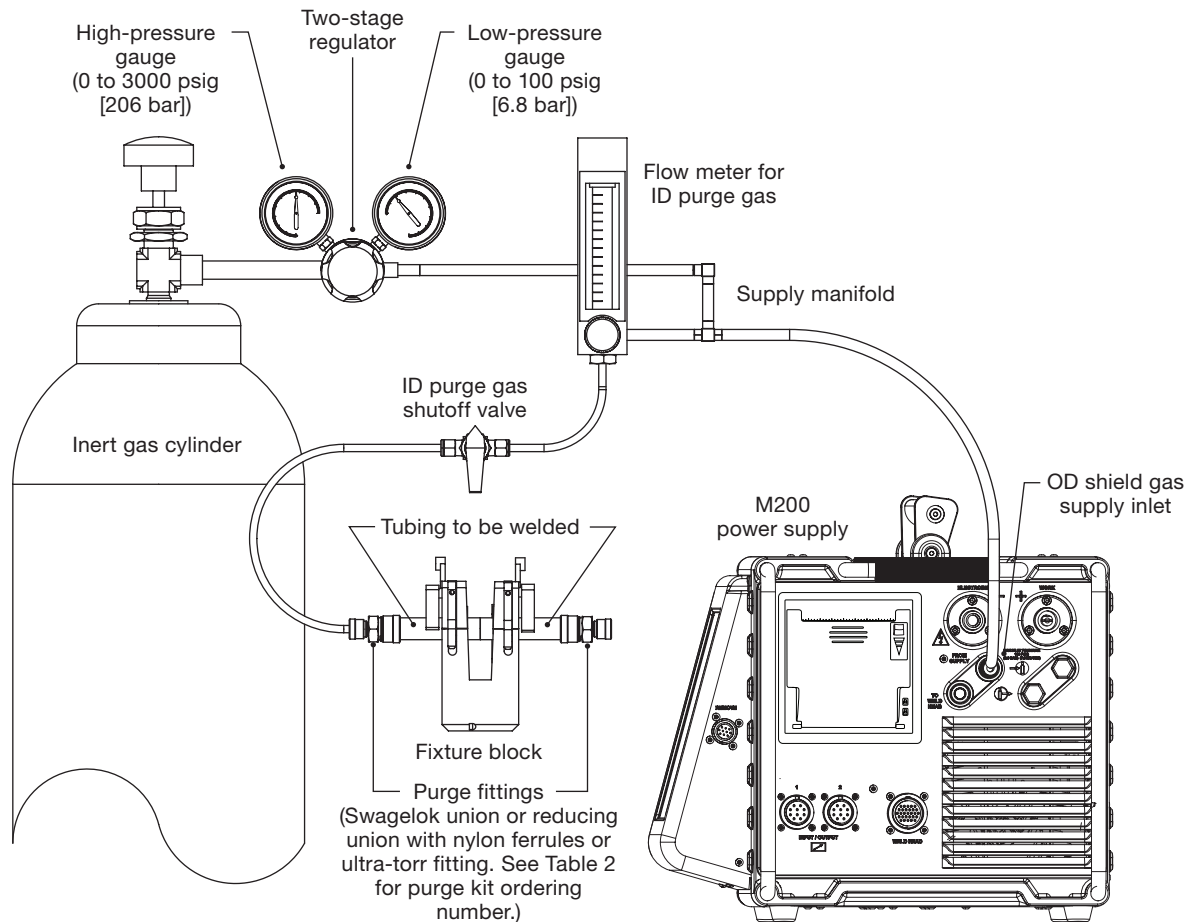

Fig. 9—Typical Gas Supply System

Powering On the M200 Power Supply for the First Time

1. Connect the power cord to a properly rated and grounded electrical receptacle.
2. Power on the M200 power supply by toggling the ON/OFF switch on the left side of the unit to the ON (I) position. The Swagelok screen will appear.
3. The Setup Wizard (Fig. 10) will prompt the user to select a user language.
4. The Swagelok Embedded System End User License Agreement (page 122) will appear. You must accept the terms of this agreement to continue the Setup Wizard and use the M200 power supply.
5. Set the owner password. If desired, set security or programmer passwords. See **Passwords**, page 48, for more information.
6. The Main Menu will appear.

Note: The fan will turn on automatically. Press the Fan button to turn the fan off.

Powering Off the M200 Power Supply

To power off the M200 power supply, toggle the ON/OFF switch on the left side of the power supply to the OFF (O) position.

Note: Do not power off the M200 power supply when updating software.

Restarting the M200 Power Supply

1. Power on the M200 power supply by toggling the on/off switch on the left side of the unit to the ON (I) position.
2. The Swagelok screen (Fig. 11) will appear.
3. Enter the security or programmer password if one has been set.
4. The Main Menu will appear.



CAUTION

The rotor will move when the M200 power supply is powered on. The rotor is a potential pinch point.



Fig. 10—Language Setup Wizard

Note: The owner password is the master key to the M200 power supply. If it is lost or forgotten, contact your authorized Swagelok representative. After ownership of the unit is verified, you will receive a temporary password to allow access to the unit.



Fig. 11—Swagelok Screen

Note: The MFC requires 5 minutes to warm up to ensure accurate gas flow control if the M200 power supply is not at operating temperature.

Using the Touch Screen

The touch screen of the M200 power supply is the built-in method for navigating functions and entering data.

The touch screen responds to fingertip operation and was designed to accommodate gloves. The touch screen may be difficult to use if it is dirty or has water droplets on its face. Keep the touch screen clean and dry.

If the touch screen does not respond as expected, it may need to be calibrated. From the Main Menu, select Setup > Touchscreen > Calibrate Touchscreen (Fig. 12). A series of cross hair targets will appear onscreen. While in the position (seated or standing) you normally use the M200 power supply, touch each target (Fig. 13) as it appears. When no more targets appear, the M200 power supply is calibrated.

User Interface

The user interface of the M200 power supply was designed for easy navigation.

The “path” at the top of each screen (except the Weld screens) indicates your location:

Path	Location
Main > Setup	Setup mode
Main > Program > Auto Create	Auto Create function in the Program mode

To select a function or mode, press the onscreen button or tab with your finger. To enter information, press the field to be filled in. Depending on the information to be entered, a numeric keypad, alphanumeric keyboard, or drop-down menu will appear. A USB mouse and keyboard also can be connected to the M200 power supply for data entry.

Numeric Keypad

The valid range for the selected parameter will display at the bottom of the keypad.

- Press the number keys (Fig. 14) to enter information. Press Done to save the settings and close the keypad.
- Press <- Bksp to erase the last character entered. Press Clear to erase the entire entry.

Note: Do not expose the M200 power supply to water or visible moisture. The touch screen can be cleaned with glass cleaner and a clean cloth. To prevent accidental operation, power off the M200 power supply before cleaning.

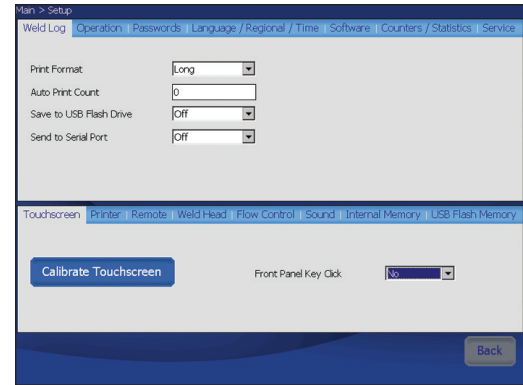

Fig. 12—Calibrate Touchscreen Button

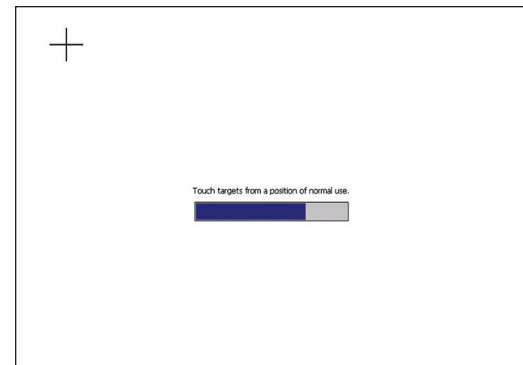

Fig. 13—Calibration Target Screen

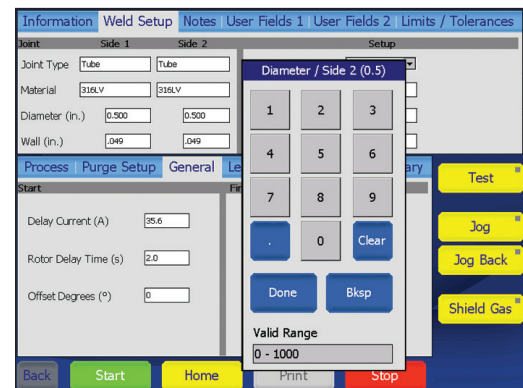

Fig. 14—Numeric Keypad

Keyboard

- Use the onscreen keyboard (Fig. 15) as you would a computer keyboard.
- To reposition the keyboard, press the gray bar at the top of keyboard and drag it to the new position.
- To close the keyboard, press return.

Note: The return key will not start a new line of text.

Table 4—Key Functions

Key	Function
Home	Moves cursor to the beginning of the line.
End	Moves cursor to the end of the line.
Prop	Moves cursor to the end of the line.
BS	Backspace. Deletes character to the left of the cursor. Also deletes selections that have been highlighted.
Tab	Closes the keyboard.
return	Closes the keyboard.
Ctrl	Ctrl + z: Undo last step. Ctrl + x: Cut and save selected/highlighted text. Ctrl + c: Copy and save elected/highlighted text. Ctrl + v: Paste saved text at cursor point.
del	Deletes character to right of cursor. Also deletes selections that have been highlighted.
lt	Moves cursor one space to the left.
rt	Moves cursor one space to the right.
up	Moves cursor to line above.
dn	Moves cursor to line below.
pgup	Moves to the preceding page.
pgdn	Moves to the next page.

Drop-Down Menus

Drop-down menus (Fig. 16) allow you to select entries from a list. Drop-down menus are indicated by a down arrow (▼). Press the field or arrow to display the list of selections. Highlight the selection to change the value.

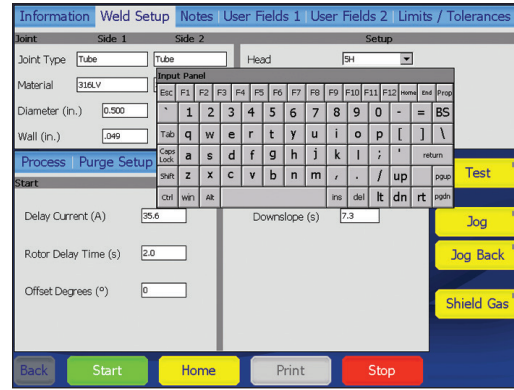

Fig. 15—Onscreen Keyboard

Note: To select text, highlight it by pressing and dragging your finger over the selection.

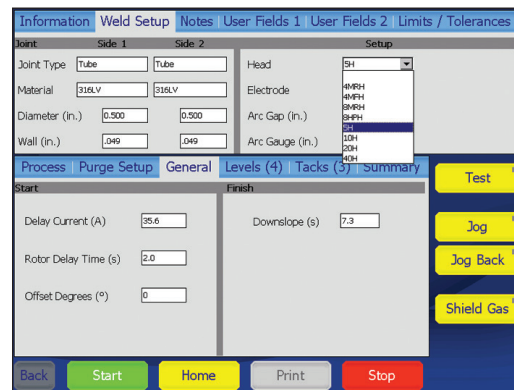

Fig. 16—Drop-Down Menu

Operation

This section describes the basic operation of the M200 power supply.

Main Menu

The Main Menu (Fig. 17) provides access to the M200 power supply's functions. Select functions by pressing the onscreen button or by using a USB mouse to click on the selection. The Main Menu buttons are described in Table 5, page 26.

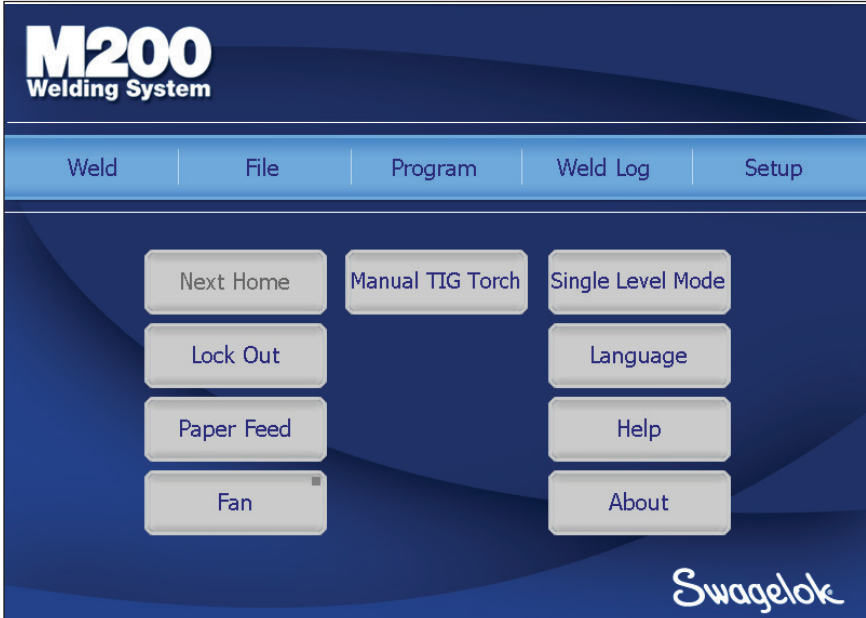

Fig. 17—Main Menu

Table 5—Main Menu Selections and Functions

Weld	<p>The Weld screens display detailed information about the weld and are used to input parameters, start the weld, and monitor the weld process. The information displayed on the Weld screens is saved with the weld procedure. See page 28 for more information about the Weld screens.</p>
File	<p>The File screens are used to print, preview, delete, load, and save weld procedures. The File mode applies only to weld procedures and does not affect the M200 power supply Setup or Weld Log files. See page 35 for more information about the File screens.</p>
Program	<p>The Program screens are used to create new weld procedures using Auto Create or Manual Create. See page 38 for more information about the Program screens.</p>
Weld Log	<p>The Weld Log screens are similar to the File screens but are exclusively for Weld Log records. Weld Log records may be viewed, printed, copied, or deleted using these screens. Weld Log records may be saved to a USB flash drive for transfer to a PC. Weld Log records may also be exported to a PC using a serial cable. See page 39 for more information about the Weld Log screens.</p>
Setup	<p>The Setup screens are used to change options, set dimensional units and passwords, and review settings. Changes are saved in the M200 power supply's internal memory and are not part of a weld procedure. The Setup mode also contains utilities for updating software, resetting weld counts, and monitoring free memory. See page 42 for more information about the Setup screens.</p>
Next Home	<p>When a Swagelok weld head is first connected to the M200 power supply, the power supply assumes the rotor is at true home. If it is not, press Next Home to move the rotor to the next of several "home" positions. The weld head model determines the number of home positions. Continue pressing Next Home until the rotor reaches true home (Fig. 18.) If the weld head cannot find true home, see Troubleshooting, page 110.</p>

Note: In any M200 power supply screen or menu, press Back to return to the previous screen. Press Refresh to reload and update the current screen.



CAUTION
The rotor will move when Next Home is pressed. The rotor is a potential pinch point.

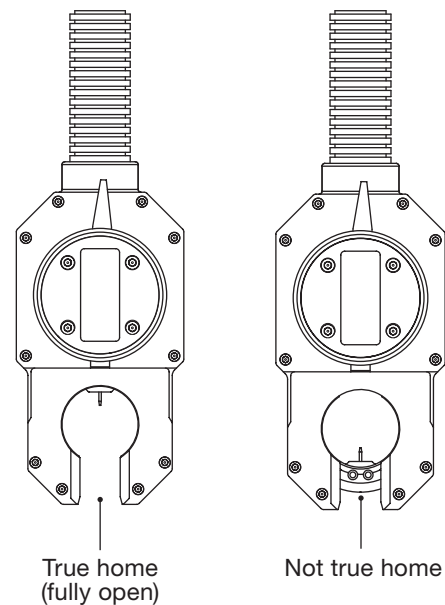

Fig. 18—Rotor Home Position

Table 5—Main Menu Selections and Functions

<p>Lock Out (Fig. 19)</p>	<p>Pressing Lock Out will lock the M200 power supply. Once the M200 power supply is locked out, pressing any button on the screen will cause a password prompt to appear. The owner, programmer, or security password must be entered. <i>Note: This feature is not available unless a programmer or security password has been set in Setup.</i> See Passwords, page 48, for more information.</p>
<p>Paper Feed</p>	<p>The printer is located on the right side of the M200 power supply, above the weld head connection. Paper Feed advances the paper through the printer. See page 47 for information on changing the paper feed length.</p>
<p>Fan</p>	<p>The fan is normally in the Fan Power-On State and will turn on as needed to cool the M200 power supply. To turn the fan on manually, press Fan. The fan will run continuously until Fan is pressed again.</p>
<p>Single Level Mode</p>	<p>Single Level Mode is for users who prefer the Swagelok D75 and D100 power supply programming format. See Single Level Mode Operation, page 86, for more information.</p>
<p>Language (Fig. 20)</p>	<p>The Language screen allows you to change the language shown on the M200 power supply's screens. Press the Language button to select the new language. As soon as the language is selected, the Back button at the bottom of the screen will display that language. Press the Back button to return to the Main Menu, and the screen will be in the selected language.</p>
<p>Help</p>	<p>Displays the user's manual. The user manual will display in the language selected if available. The English version will display if it is not available.</p>
<p>About</p>	<p>Displays copyright and patent information.</p>

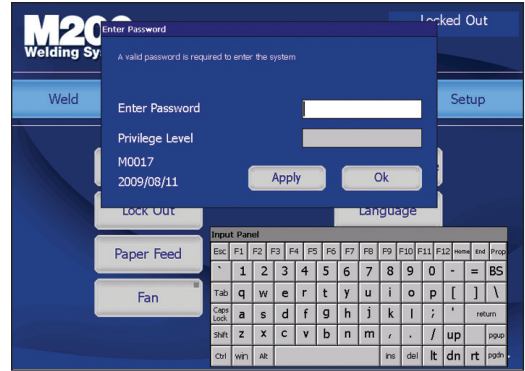

Fig. 19—Password Prompt Screen

Note: Changing the Fan Power-On State to off on the Setup > Operation tab will prevent the fan from turning on automatically when the M200 power supply is powered on.



Fig. 20—Language Screen

Weld Screens

The Weld screens (Fig. 21) are used to view and adjust (see Note) the parameters of the active weld procedure. The screen is divided into upper and lower sections.

The Upper Section Tabs contain information related to the weld procedure and options: user fields, limits / tolerances, etc.

The Lower Section Tabs are fields that make up the basic parameters of a weld: purge settings, levels, tacks, and general settings.

Note: Changing the weld procedure parameters will add "(modified)" to the weld procedure name on the screen and cause the name to turn red in color. The weld procedure must be saved to make the changes a permanent part of the procedure. See Table 9, page 36.

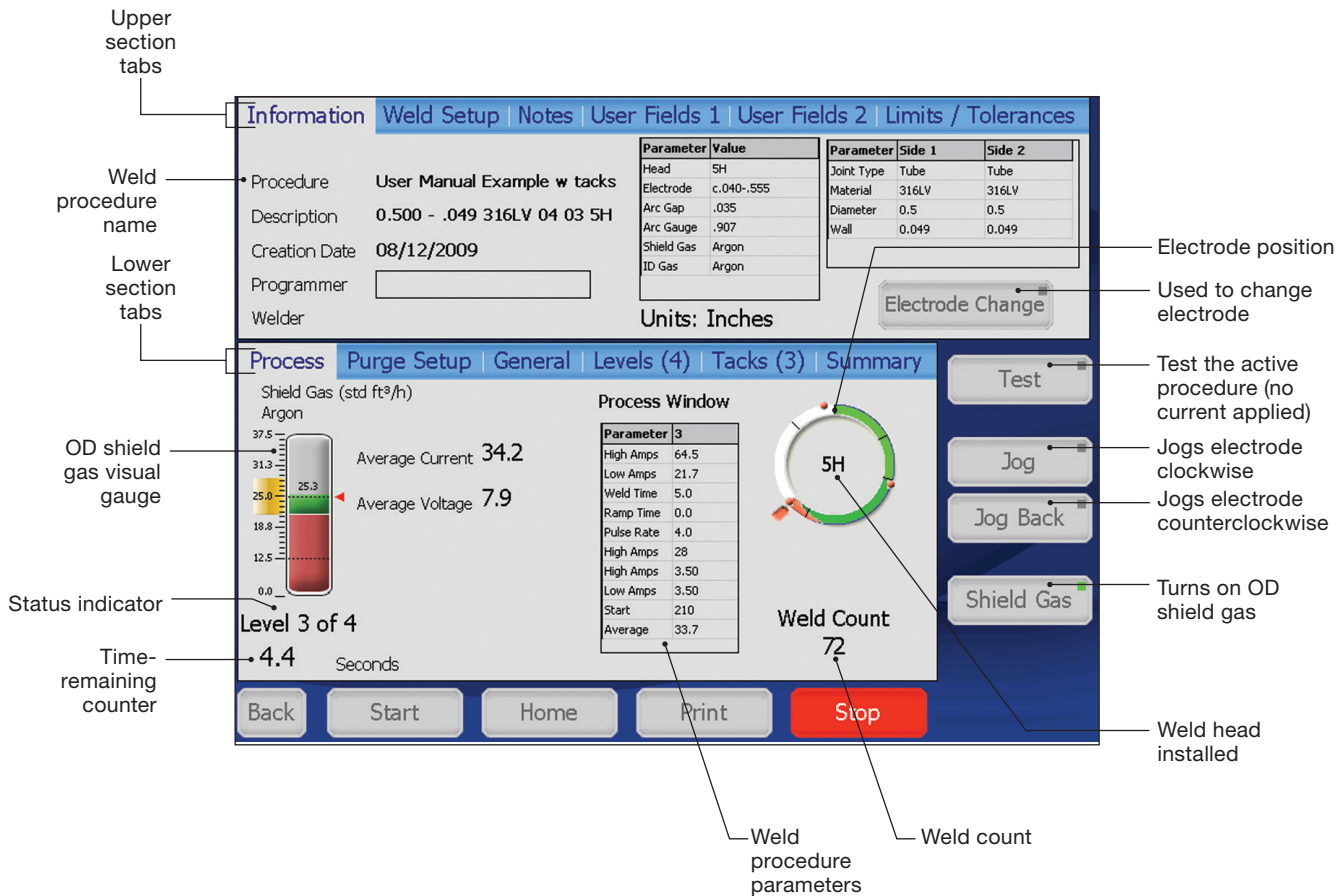

Fig. 21—Weld Screens

Table 6—Weld Upper Section Tabs

<p>Information (Fig. 21)</p>	<p>Displays a summary of weld setup parameters as well as ID purge and OD shield gas types for the active weld procedure. The eight most recent entries for the Programmer field will display in a drop-down box.</p> <p>The Information tab also displays the Electrode Change button, which positions the rotor for electrode replacement and prevents the M200 power supply from welding.</p> <p>See the weld head user's manual for instructions on electrode replacement. After replacing the electrode, press Electrode Change again. The rotor will move back to the home position.</p>
<p>Weld Setup (Fig. 22)</p>	<p>Displays the Joint and Setup fields and allows adjustment of values.</p>
<p>Notes</p>	<p>Displays an open field for entering comments and observations. Press the white area once to display the onscreen keyboard. Notes will be saved with the weld procedure and shown in the Weld Log as Procedure Notes.</p>
<p>User Fields 1 User Fields 2 (Fig. 23, Fig. 24)</p>	<p>Displays User Fields 1 and 2.</p> <p>The software will remember the eight most recent entries for each field and display them in a drop-down box.</p> <p>The owner or programmer can set data entry requirements that must be completed before a weld is performed. This information is part of the weld procedure and is stored in the Weld Log.</p> <p>Three options are available in drop-down boxes next to each user field:</p> <p>No An entry is not required for this field. It may be entered at the discretion of the user.</p> <p>Yes An entry is required for the field. The entry will remain in that field until a new weld procedure is loaded. Failure to enter information into this field will cause a disable code.</p> <p>Change An entry is required in the field and must be reentered with every weld. Failure to enter information into this field will cause a disable code.</p>



CAUTION
The rotor will move when Electrode Change is pressed. The rotor is a potential pinch point.

Note: Electrode Change disables most other M200 power supply buttons.

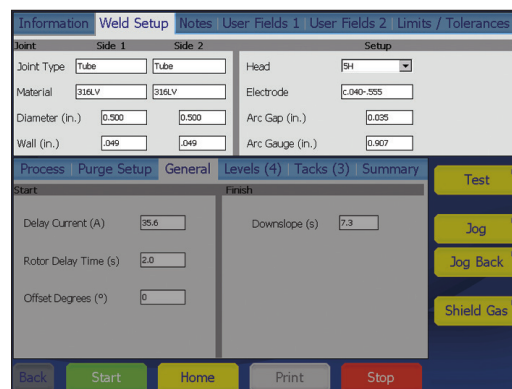

Fig. 22—Weld Setup Tab



Fig. 23—User Fields 1 Tab

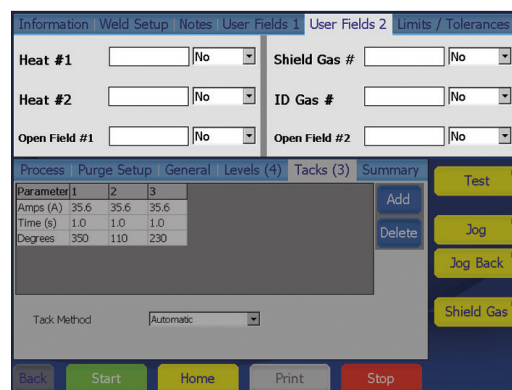

Fig. 24—User Fields 2 Tab

Table 6—Weld Upper Section Tabs

<p>Limits / Tolerances (Fig. 25)</p>	<p>Limits</p> <p>Limits are used to restrict the amount of adjustment a user with a security password can make without entering a programmer or owner password.</p> <p>Limits from 0 to 100 % are set at the programmer and owner levels. Current and Purge Limits are represented as a percentage of the weld procedure values.</p> <p><i>Example: if the Average Amps for Level 1 is 100 A and the current limit is 50 %, the M200 power supply will not allow an adjustment of Average Amps above 150 A or below 50 A. The factory default for limits is 100 %.</i></p> <p>Average Amps can be adjusted within the limits on the lower section Levels tab using the up and down buttons.</p> <p>See Adjusting Average Amps, page 31, for more information.</p> <p>Purge parameters can be adjusted within the limits on the Purge Setup tab.</p> <p>Tolerances</p> <p>The Weld Log records out-of-range values for Average Amps, Average Speed, and OD Shield Flow in the Weld Log, based on tolerances set. Tolerances are adjustable at the programmer and owner levels, as a percentage of the base value.</p> <ul style="list-style-type: none"> ■ Current and speed tolerances are adjustable up to 9.9 %. The factory default for new weld procedures is 2.5 %. ■ Purge tolerance is adjustable up to 100 %. The factory default is 15 %. <p><i>Example: if the Average Amps for Level 1 is 100 A and the current tolerance is 5 %, the M200 power supply will return a current tolerance error at the end of the weld if the Average Amps is below 95 A or exceeds 105 A.</i></p> <p>Current tolerance. If the Average Amps tolerance is exceeded during the weld, a current tolerance error will be recorded.</p> <p>Speed tolerance. If the average speed is outside of the average speed tolerance at the end of the weld, a speed tolerance error will be recorded.</p> <p>Purge tolerance. Purge tolerance is represented by the yellow band in the shield gas flow meter displayed on the process tab. If the OD shield flow is outside of the tolerance, the shield gas bar flow meter display will turn red. If there is no OD shield gas present during prepurge, the M200 power supply will not proceed. If the OD shield gas flow drops below 8 std ft³/h (3.8 std L/min) during a weld, the M200 power supply will stop welding to prevent possible damage to the weld head.</p> <p>See page 107, Weld Errors.</p>
---	--



Fig. 25—Limits / Tolerances Tab

Table 7—Weld Lower Section Tabs

<p>Process (Fig. 26)</p>	<p>Displays the status and progress of the weld, including tacks, error messages and electrode position.</p>
<p>Purge Setup (Fig. 27)</p>	<p>Displays the Normal Purge, Blast Purge, and Gas Type fields.</p>
<p>General (Fig. 28)</p>	<p>Displays the Start and Finish fields.</p>
<p>Levels (X) (Fig. 29)</p>	<p>A level is a section of the weld procedure defined by the parameters shown in Fig. 29. Parameters can be varied by level.</p> <p>A weld procedure can have from 1 to 99 levels. The number in parentheses indicates the number of levels specified in that weld procedure.</p> <p>Levels are shown in the process window in real time during the weld. To add a level, press the top of a column to highlight it, then press the Add button on the right side of the window. A new column containing a copy of the selected column's data will be added after the selected column. Repeat for additional levels.</p> <p>To delete one or more levels, press the top of the column or columns to select them. Press the Delete button on the right side of the window.</p> <p>Adjusting Average Amps</p> <p>Adjust Up / Down allows a user with a security password to make Average Amps adjustments within the limits and tolerances set by the owner or programmer.</p> <p>Select the level or levels to be adjusted and press the up or down buttons to adjust Average Amps (page 30) within the limits in a weld procedure defined by the programmer. If no level is selected, <i>all</i> levels are affected by Adjust Up / Down.</p> <p>Average Amps is reduced with the down button or increased with the up button.</p> <ul style="list-style-type: none"> ■ The first three presses of the up or down button increase or decrease <i>High Amps Width</i> in increments of 10 %, up to 30 %. ■ The next three presses of the up or down button increase or decrease <i>High Amps</i> in increments of 10 %, up to 30 %. ■ The final three presses of the up or down button increase or decrease <i>Low Amps</i> in increments of 10 %, up to 30 %. <p>To return to the original values for the weld procedure you must reload the program from memory.</p> <p>See Limits / Tolerances, page 30, for more information.</p>



Fig. 26—Process Tab

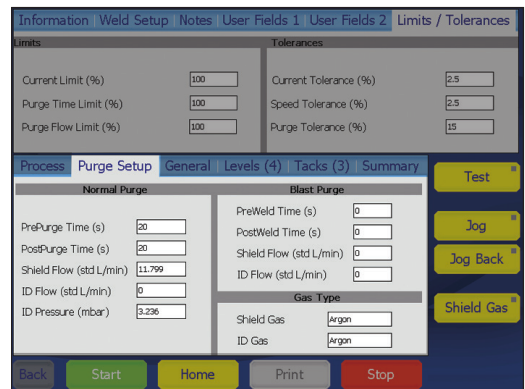

Fig. 27—Purge Setup Tab

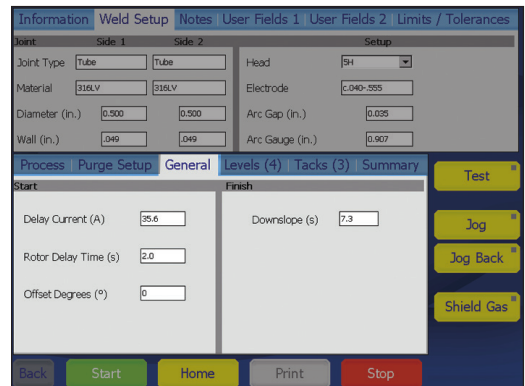

Fig. 28—General Setup Tab

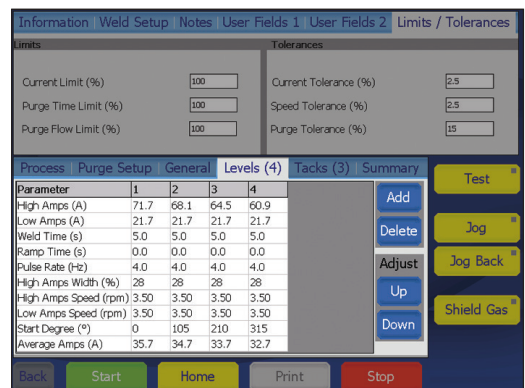

Fig. 29—Levels Tab

Table 7—Weld Lower Section Tabs

<p>Tacks (X) (Fig. 30)</p>	<p>The M200 power supply supports weld procedures with tacks—nonpenetrating spot welds used to hold work pieces in place. The number in parentheses indicates the number of tacks specified for the weld procedure.</p> <p>To set the tack method, choose from the options available in the drop-down box next to the user field:</p> <p>Automatic The entire selected weld procedure will be completed when the Start button is pressed on the Process tab.</p> <p>Tacks Only Only the tacks portion of the selected weld procedure will be completed. When the user returns to the Process tab, a Start Tacks button will appear under the Weld Head Installed graphic. Press this button to complete the tacks. The Start button will change to Start Levels. Press this button to begin the remainder of the weld procedure.</p> <p>To add tacks, press the top of a column to highlight it, then press the Add button on the right side of the window. A new column containing a copy of the selected column's data will be added after the selected column. Repeat for additional tacks.</p> <p>To delete tacks, press the top of the column or columns to select them, then press the Delete button on the right side of the window.</p> <p>Use the onscreen keypad to enter or change a parameter. See page 67 for more information about weld procedures using tacks.</p>
<p>Summary (Fig. 31)</p>	<p>This tab provides information on the M200 power supply's Disable, Operational, and Error conditions when a weld procedure is loaded.</p> <p>The View button allows a look at the last completed weld in the Weld Log.</p> <p>The Clear Errors button remove all nonactive errors from the Summary View (but not the Weld Log.)</p> <p>Choose the Active Only check box to limit the Summary View to the active weld.</p> <p>Weld Log notes will print with the Weld Log.</p>

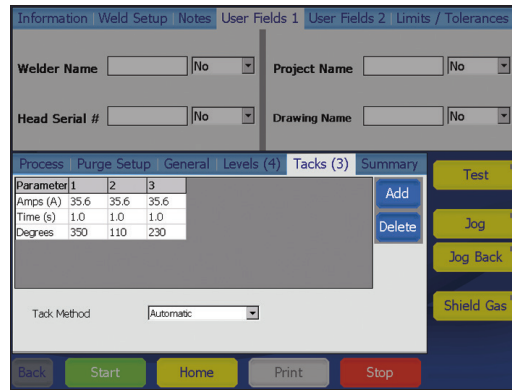

Fig. 30—Tacks Tab

Note: Tacks should be offset at least 10° from the location of the arc start of the levels to prevent arc wander at arc start. The weld head returns to the true home position after the tacking section of a weld procedure.

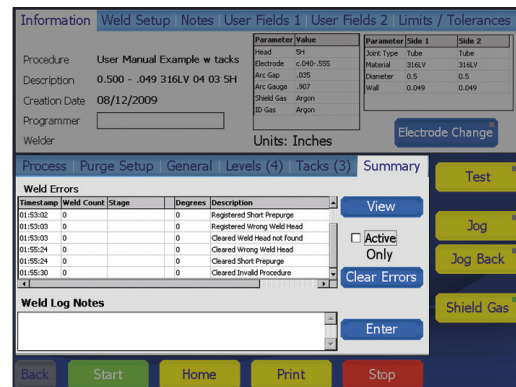

Fig. 31—Summary Tab

Table 8—Weld Screen Buttons

Test	Check or demonstrate a weld procedure with this mode. Press to put the power supply in an alternate operating mode that will not supply current to the electrode. Press again to stop. The current and voltage displays will not operate and the weld counter will not advance. The light in the corner of the button will blink while the power supply is in Test mode.
Jog	Press to move rotor <i>clockwise</i> . Press again to stop. The light in the corner of the button will blink while the rotor is moving.
Jog Back	Press to move rotor <i>counterclockwise</i> . Press again to stop. The light in the corner of the button will blink while the rotor is moving.
Shield Gas	Activates the mass flow controller and starts the flow of OD shield gas to the weld head. Shield gas will flow to the weld head until you press the button again. Pressing the Shield Gas button does not override Purge Setup settings in the weld procedure, but gas will continue to flow after the weld procedure is complete.
Start	Starts the weld process. See Performing a Weld , page 34.
Home	Press to return the rotor to its true home position. The rotor will move at maximum speed when traveling to the home position, regardless of the programmed rotor speed.
Print	Prints last completed Weld Log record.
Stop	Aborts the weld and halts the rotor if pressed during the weld process. Stop also turns off OD shield gas flow.

Performing a Weld

Read and understand all safety information contained in this manual before starting the weld.

1. Complete all side panel connections as described in **Setting Up the M200 Power Supply**, page 19, **Installing the Weld Head**, page 20, and **Setting Up the Gas Supply System**, page 21.
2. Install the electrode and set the arc gap using the arc gap gauge in accordance with the weld head user's manual.
3. Install the collets in the fixture block.
4. Align and clamp the work pieces in the fixture block.
5. Load an existing weld procedure as described in **Load / Save / Print / Delete Tab**, page 35, or create a new weld procedure as described in **Program**, page 38.
6. Connect the ID purge gas line to the work pieces to be welded and set the flow meter.
7. Connect the weld head to the fixture block.
8. Press the Start button.

Display Indications During Welding

During welding, the status messages are displayed on the Process tab, along with a time-remaining counter.

After the Weld is Complete

1. The M200 power supply will return to the "Ready" state.
2. Check the fixture block to confirm that it has cooled before handling. Increasing the postpurge or blast purge postweld time will aid cooling.
3. Remove the weld head from the fixture block. If it is difficult to remove, release one of the side plate levers.
4. Remove the ID purge gas lines from the welded assembly.
5. Remove the welded assembly.

Weld Status Conditions

See **Troubleshooting**, page 103, for a list of disable, operational, and weld error conditions.



WARNING

Do not touch the cable connectors during the weld. If the cables have been damaged, the potential for an electrical shock exists.



CAUTION

Use gloves or other protective devices if you must handle parts immediately after welding. The parts can be extremely hot and may cause burns.

NOTICE

Do not immerse the hot fixture block in water after welding. Allow the fixture block to cool before performing the next weld.

Note: Inspect the electrode after each weld. Look for oxidation, wear, or weld material on the tip.

File Screens

The File screens are used to load, save, print, copy, delete, and view weld procedures.

The Main > File screen has two tabs:

- Load / Save / Print / Delete
- File Copy

When the File screen opens, the M200 power supply searches the internal memory and a connected USB flash drive. A large number of folders can slow the search process. To reduce the time required, delete unnecessary files or folders in the internal memory and on the USB flash drive.

Load / Save / Print / Delete Tab

The File screen opens in the Load / Save / Print / Delete tab, showing Folder and File Views in separate panes (Fig. 32):

- The Folder View displays folders for the internal memory and a connected USB flash drive.
- The File View displays the weld procedures contained in an open folder. The active weld procedure will have a green icon.

In the Folder View, press the folder name or icon to open it. The weld procedures will be displayed in the File View pane in alphabetical order. The Folder View will also display any subfolders contained in the original folder.

The buttons on the lower left (Print, View, Delete, and Load) require you to select a file or folder before you press a button.

Press a weld procedure in the File View pane to highlight it. The weld procedure name will appear in the File Name box below the File View pane.

Enter a file name in the File Name box before pressing the Save, Rename, or Create Folder buttons on the lower right of the screen.

When a file name is entered and saved, a description that includes the OD, wall thickness, tubing material, number of levels, number of tacks, and weld head model will be added automatically to the file name and displayed in the File View, and whenever the weld procedure is loaded:

User's manual example [0.500 - 0.049 316LV 04 03 5H A]

User's manual example	programmer-selected file name
0.500	OD of work piece
0.049	wall thickness of work piece
316LV	tubing material
04	number of levels
03	number of tacks
5H	weld head model needed for weld procedure
A	ATW weld procedure
P	pipe schedule
S	step program

The display will automatically change to the Weld/Process tab after a Save has been performed.

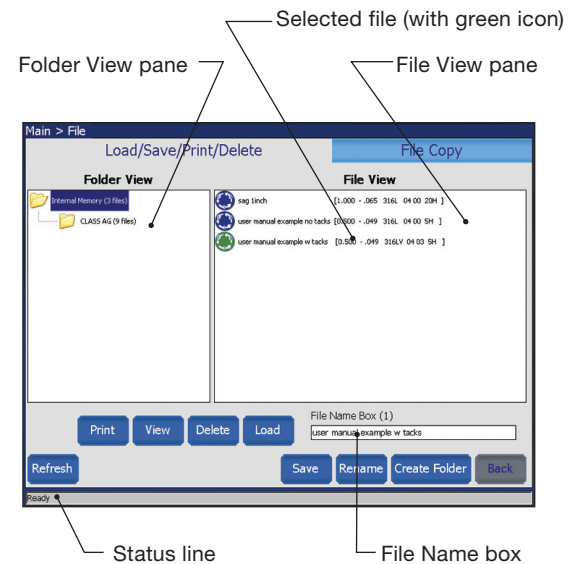

Fig. 32—Load / Save / Print / Delete Tab

Note: File names are limited to alphanumeric characters. The M200 power supply software does not support symbols such as: ÷, +, -, %, /, ", ', " ', or similar characters.

Table 9—Load / Save / Print / Delete Tab Buttons

Print	Select the weld procedure in the File View pane and press Print.
View	Select the weld procedure from the File View pane and press View. The file preview window will appear showing the weld procedure name, a description, the programmer's name, and the date the weld procedure was saved. Joint, Level, and Tack parameters will also be displayed. Press OK to return to the File screen.
Delete	Select the weld procedure or folder and press Delete. A dialog box will open asking you to confirm the delete. Press Yes to delete the weld procedure or folder.
Load	Select the weld procedure from the File View pane and press Load. A message in the Status line will confirm that the weld procedure was successfully loaded.
Save	Select the folder in which to save the weld procedure. Press the File Name box. The keyboard will appear. Enter the name of the new weld procedure and press Save. The weld procedure will be saved and displayed in the File View pane.
Rename	To rename a weld procedure, select the weld procedure. The weld procedure name will be shown in the File Name box. Press Rename and an input box and a keyboard will be displayed. Enter a new file name and press Rename in the input box.
Create Folder	Create Folder allows you to create an empty subfolder in internal memory or on the USB flash drive. To create a new subfolder, highlight the folder you want to put the new subfolder in and select the File Name box. Enter the name of the new folder using the keyboard and press Create Folder. The new subfolder will appear in the Folder View pane.

Note: Folders cannot be renamed using Rename.

File Copy Tab

The File Copy tab (Fig. 33) allows the user to copy folders and files between folders in internal memory or to and from a USB flash drive.

When the File Copy tab opens, the internal memory and USB Flash Drive (if attached) folders will be shown in both folder panes. Press a folder *twice* to display its contents. Press *twice* again to close it.

To copy a file, select the destination folder and the file to copy. Press Copy >> or << Copy. If you select a folder, the entire folder will be copied.

The Folder Move fields show the name of the folder or file selected. The Status line at the bottom of the screen displays status and error messages.

Table 10—File Copy Tab Buttons

Copy >>	Copies the selected folder or file from the left Folder Move field to the selected destination in the right Folder Move field.
<< Copy	Copies the selected folder or file from the right Folder Move field to the selected destination in the left Folder Move field.

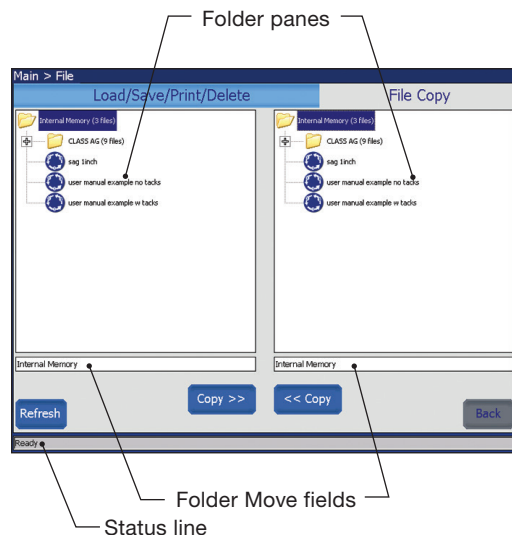

Fig. 33—File Copy Tab

Program Screens

The Program screens (Fig. 34) are used to create new weld procedures using Auto Create or Manual Create.

Table 11—Program Screen Buttons

Auto Create

(Fig. 35)

When you select Auto Create, a dialog box will ask you to confirm overwriting the active weld procedure. Press Yes to overwrite the active weld procedure.

The active fields on the Auto Create screen are shown in black. As these fields are completed, the inactive fields (in gray) will activate in response to the entries.

The eight most recent entries for the Programmer field will display in a drop-down box.

To change the # Levels and # Tacks entries from the default, press the field to display the keypad. Enter your changes and press Done.

The Save Procedure drop-down box has two options:

- Active (No - Save) will take you directly to the Main > Weld screen for immediate use. You can run the weld procedure and make changes before saving.
- Save Procedure will take you to the Main > File screen. On this screen you can enter a name for the weld procedure and save it to internal memory or the external USB flash drive.

Manual Create

(Fig. 36)

Manual Create allows programmers to write their own weld procedures using the Weld screens. When you select Manual Create, a dialog box will open, asking you to confirm overwriting the active weld procedure. Press Yes to overwrite the active weld procedure.

The Weld screen will open, with all data cleared, so that you can enter parameters for a new weld procedure.

See **Weld Parameter Development**, page 54, for more information and worksheets for use in developing a weld procedure.

The Manual Create screen may also be used to clear the active weld procedure.

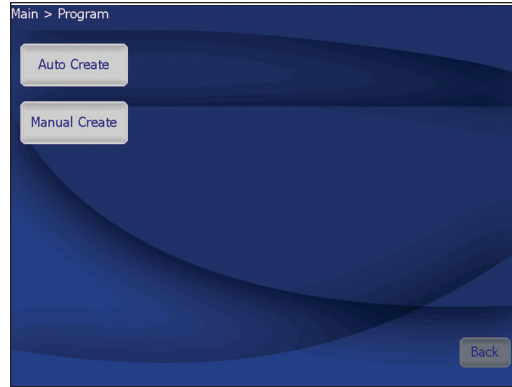

Fig. 34—Program Screen

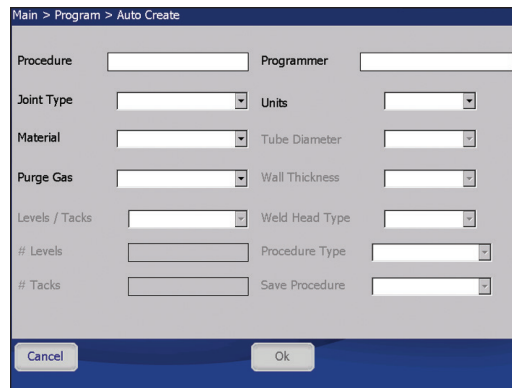

Fig. 35—Auto Create Screen

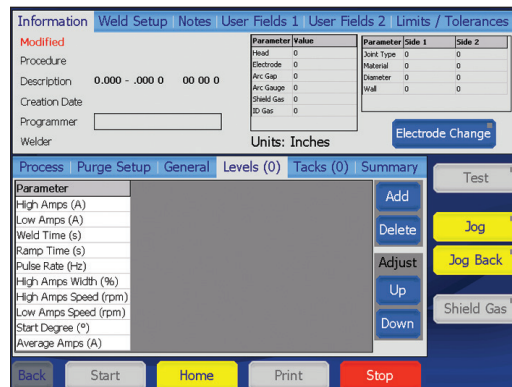

Fig. 36—Manual Create Screen

Weld Log Screens

A Weld Log record is saved to internal memory for every completed weld. This feature cannot be disabled, but Weld Log records can be deleted after they are saved to internal memory. The Weld Log records the following data:

Description	Weld procedure, with specific settings
Inputs	Weld level information
Outputs	Weld results
Performance Confirmation	Operational conditions, errors, notes

The Weld Log screen has two tabs:

- View / Print / Serial
- Export / Copy / Delete

The Weld Log screen manages Weld Log records, which are saved to the Internal Memory\Weld Log folder. Subfolders cannot be created in the internal memory\Weld Log folder. Weld Log files can be copied to an external USB flash drive. Subfolders can be created on the USB flash drive.

After every completed weld, a Weld Log file name is created automatically in accordance with the following convention:

2007-09-27 10-56 00012 001251 123456.xml
 2007-09-27 date
 10-56 time (24 h clock)
 00012 weld counter (resettable)
 001251 arc start counter (nonresettable)
 123456 M200 power supply serial number
 .xml file format

View / Print / Serial Tab

The Weld Log screen opens in the View / Print / Serial tab, displaying two panes (Fig. 37):

- Folder View (left pane) displays folders in the Internal Memory\Weld Log and the USB flash drive\Weld Log (if drive is connected).
- File View (right pane) displays the files contained in the selected folder in the Folder View pane.

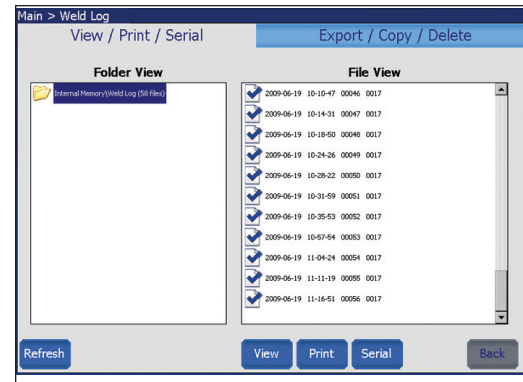

Fig. 37—View / Print / Serial Tab

Table 12—View / Print / Serial / Tab Buttons

View	Select the Weld Log from the File View pane and press View. The File Preview window will appear, showing the weld procedure name, the weld count, performance confirmation (including any errors), and time created. Joint, Level, and Tack parameters will also be displayed. Press OK to return to the Weld Log screen.
Print	Prints the selected Weld Log record.
Serial	Transfers files and folders directly to a PC using a serial cable. <i>M200 power supply serial port settings:</i> Baud rate: 38 400 Data bits: 8 Parity: None Stop bits: 1 Flow control: None

Export / Copy / Delete Tab

The Export / Copy / Delete tab (Fig. 38) opens, showing two panes:

- Internal Memory / USB Flash Drive (left pane) displays the folders in the Internal Memory \ Weld Log and USB Flash Drive \ Weld Log (if drive is connected).
- USB_Flash_Drive_ONLY (right pane) displays the folders for USB Flash Drive \ Weld Log.

The selected folder and files will appear in the Name field below the pane.

Table 13—Export / Copy / Delete Tab Buttons

Export (Fig. 39)	<p>The Export button allows the Weld Log record to be exported from the Internal Memory\Weld Log into a text file.</p> <p>Each Weld Log record is a separate line. Fields are separated by commas within the Weld Log. The exported file can be imported into Microsoft® Excel® or Access®.</p> <p>Select the folder to be exported and press Export. The Weld Log Export dialog box will open. The From and To locations will be shown.</p> <p>Enter a file name in the Weld Log Name field.</p> <p>Check Append to File if the file name already exists and you want to add the data to the file. If the file name exists and Append to File is not selected, the file will be overwritten.</p> <p>Select a Date Range, Dimensional Units, Flow Units, Pressure Units, and Date Format and press Export.</p>
Copy	<p>Select a folder or file from the Internal Memory / USB Flash Drive pane and press Copy. The folder or file will be copied to the USB flash drive folder on the right.</p>
Create Folder	<p>Allows you to create an empty folder in the USB Flash Drive / Weld Log folders. Folders you create must go into a previously existing folder.</p> <p>To create an empty folder, highlight the USB Flash Drive folder you want to put the new folder in. Press the Weld Log Name field below the USB Flash Drive pane. Type in the name of the new folder and press Create Folder.</p> <p>The new folder will appear in the USB Flash Drive / Weld Log folders in both panes.</p>
Delete	<p>Folder contents can be deleted from internal memory and the USB flash drive. To delete a folder and its contents, highlight the folder and press Delete. A dialog box will ask you to confirm the delete. Press Yes to delete the folder.</p>

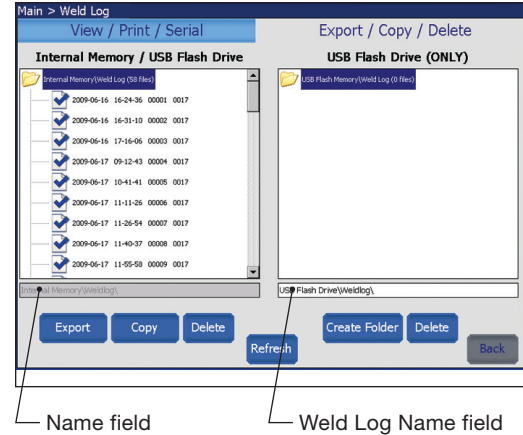

Fig. 38—Export / Copy / Delete Tab

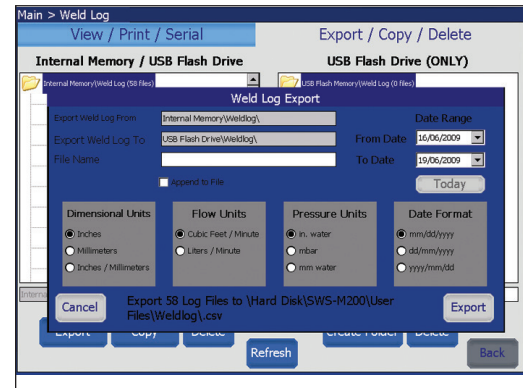

Fig. 39—Weld Log Export Dialog Box

Setup Screens

The Setup screen (Fig. 40) is divided into upper and lower sections.

The Upper Section Tabs apply primarily to system parameters: passwords, language, software, etc.

The Lower Section Tabs apply primarily to hardware parameters: touch screen, printer, flow control, etc.

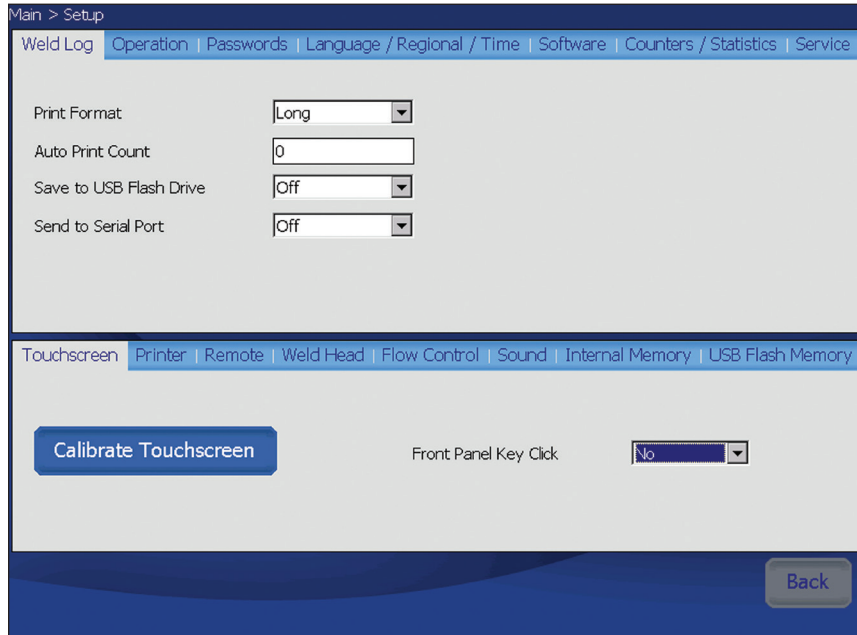

Fig. 40—Setup Screen

Ethernet Instructions

This software enables the ethernet connection on the M200 power supply, with operating version 4.1 and application version 4.101 software or later, to export weld logs to a network drive. The export weld log function can either be performed through a manual batch process or with an automatic download after each weld.

Weld logs are exported into a comma separated values (.csv) format, which can then be imported into Microsoft® Excel®. An export to a network drive will contain information identical to that which can be exported to a USB drive.

Use these instructions in conjunction with the *M200 Power Supply User's Manual*, MS-13-212.

Network Requirements

Note: Contact your IT department for your network specifications and software compatibility.

- SMB/CFIS version 2.002 to 3.1.1 dialect and other compatible versions are supported (Note: Version 1.0 is not supported by the M200)
- DNS service must be provided if using “host names” in the network mapping name
- DHCP server is required for assigning an IP address to the M200
- NetBIOS is not required

Setup

1. Navigate to the Setup/Ethernet tab from the M200 main menu.
2. Check the “Enabled” box to enable the ethernet connection; uncheck to disable. This will require OWNER privileges.

Note: Unchecking this box will prevent the M200 from accessing a network. This may be required on some sites for security reasons.

Note: Once the “Enabled” box has been checked by a user with OWNER privileges, PROGRAMMER privileges can be used to access the network and export weld logs. The user name and password required are your network credentials.

3. Enter the user-defined network destination in the Weld Log Path field, i.e., \\server name\destination folder. You can use a direct IP address to a server or network drive name as long as the network has DNS services. The domain name may not be required.

Note: The same folder location may be used for weld log exports from all M200 power supplies on your site if permitted by your IT department. For any questions on your network setup specifics, please contact your IT department.

Ethernet Operations

Manual Batch Export to Network Drive

Initiate a batch network export by selecting the “Batch Network Export” button on the Weld/Summary tab. A message box for confirmation will be displayed and show the number of logs being exported. A progress bar will show status with no additional actions required by the user.

- The network file name is auto-generated to include the date, time, and serial number of the M200 that generated the file. The file will include all new weld logs created since the last batch export was sent. It will be sent to the network drive as one combined .csv file.

Note: The last successful batch export transmitted is stored locally on the M200. This does not include any automatic weld log exports.

- In order to send previously transmitted weld logs to a different network location or resend to the same network location, the “Reset Network Weldlog” button must be selected on the SETUP screen. Pressing “Reset Network Weldlog” clears the history of weld logs sent via Main > Weld Summary Tab (Batch Network Export). A confirmation box will then be displayed.

Note: Changes on this screen require PROGRAMMER or OWNER privileges.

Note: This does not delete the weld logs from the M200.

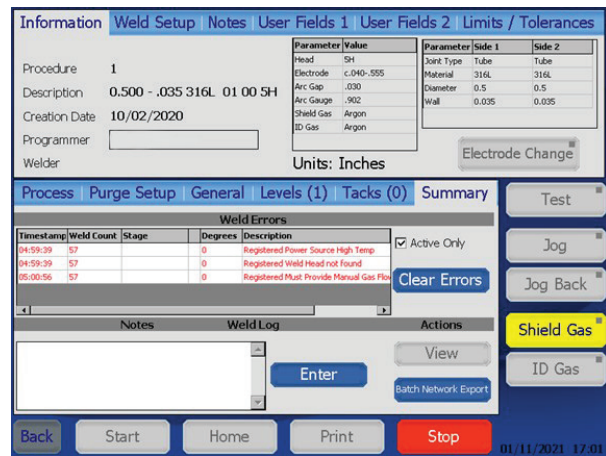

Automatic Weld Log Export to Network Drive

Change “Export To Network” on the drop-down menu to “On” on the SETUP screen to enable automatic weld log exports to the network after each weld. With this option enabled, the network connection is checked during idle conditions and a warning will be displayed if the network is not present.

- A .csv file with the last performed weld log information will be automatically transmitted after each weld to the network drive specified on the SETUP screen.
- If the M200 is unable to send the weld log file to the network, a message box will be displayed and indicate that weld logs are being stored and will be sent once the network is available.

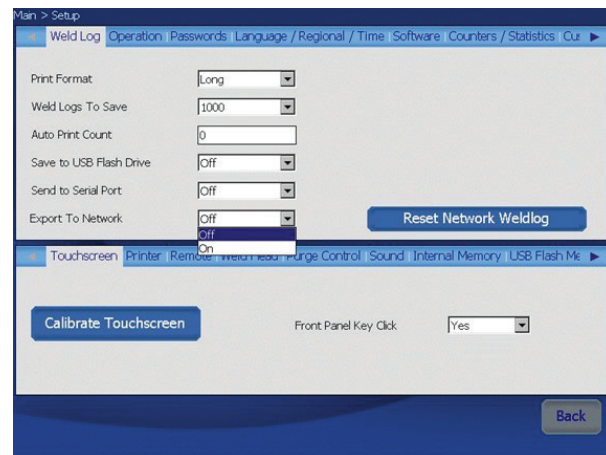

For additional information, contact your authorized Swagelok sales and service center.

Table 14—Setup Upper Section Tabs

<p>Weld Log (Fig. 41)</p>	<p>Specifies the frequency of the Weld Log printout. When set to zero, the printer prints out a Weld Log only when the Print button is pressed. Setting Auto Print Count to any other number defines the interval at which Weld Logs are printed: set to 1, the printer prints after every weld; set to 10, the printer prints after every 10th weld, etc.</p>
<p>Operation (Fig. 42)</p>	<p>Allows the user to set some of the M200 power supply functions:</p> <p>Jog Speed %: Enables the user to set the speed of the weld head when jogging as a percentage of the weld head full speed. See the weld head user's manual for the full speed ratings of individual weld heads.</p> <p>Electrode Touch Volts: This is the voltage setting used to detect if the electrode touches the weld puddle. The factory setting of 4 V should not be adjusted without testing, but may have to be raised when using longer weld head extension cables. Raising the voltage makes the M200 power supply more sensitive and can cause it to record an electrode touch when there was none and generate an error code. Lowering the voltage can allow an electrode touch without generating an error code.</p> <p>Fan Power-On State: The default setting for the fan power-on state is ON. The first time the M200 power supply is powered on, the fan button on the Main screen will blink and the fan will be in the continuous run state. Changing the Fan Power-On state to OFF will make the default for the fan button on the main screen OFF. The user can not disable the fan during the weld cycle. The fan is always on during the weld cycle.</p>

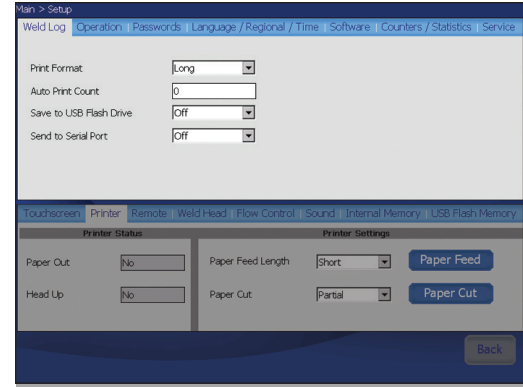

Fig. 41—Weld Log Tab

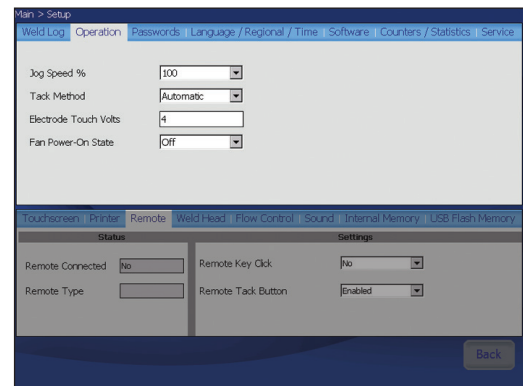

Fig. 42—Operation Tab

Table 14—Setup Upper Section Tabs

<p>Passwords (Fig. 43 , Fig. 44, Fig. 45)</p>	<p>Shows the current privilege level of the user screen and allows passwords to be set or reset.</p> <p>Setting Passwords The owner password is set in the Setup Wizard the first time the M200 power supply is powered on. To set security or programmer passwords:</p> <ul style="list-style-type: none"> ■ Press the Current Privilege Level button (Fig. 43, set by default at the Programmer level). A drop-down menu (Fig. 44) will appear on the right side of the screen that allows you to choose the level of security for the M200 power supply. ■ Select Owner If you choose to set passwords. You can now use the Change Security and Change Programmer buttons to set these passwords (Fig. 45). <p>Resetting Passwords The Current Privilege Level button displays the level of security in effect:</p> <ul style="list-style-type: none"> ■ With owner privilege, you can reset any password. ■ With programmer privilege, you can reset the programmer or security password. ■ With security privilege, you can reset the security password. <p>Press the Change Owner, Change Security, or Change Programmer buttons to reset the passwords.</p> <p>Removing Passwords Programmer and security passwords can be removed by pressing Enter on the prompt screen before entering a new password. The owner password can be reset but not removed. See Passwords, page 48, for more information.</p>
<p>Language / Regional / Time (Fig. 46)</p>	<p>Dimensional units, time and language are set from this tab. These settings will affect most screens.</p>
<p>Software</p>	<p>Displays the current software version and enables software updates. To update software:</p> <ul style="list-style-type: none"> ■ Insert the USB flash drive containing the software update into a USB A port on the M200 power supply and press Update Software. Enter the owner password and carefully follow the onscreen prompts. ■ Do not power off the M200 power supply during the software update. The update will take approximately 5 minutes. ■ Restart the M200 power supply after the software update is complete for the updates to take effect.
<p>Counters / Statistics</p>	<p>The read-only section keeps track of arc starts, welds, and misfires. The User Counters section allows setting the weld counter and gives the option of counting the weld misfires in with the weld counter.</p>
<p>Service</p>	<p>Displays the serial number and the last calibration date of the M200 power supply.</p>

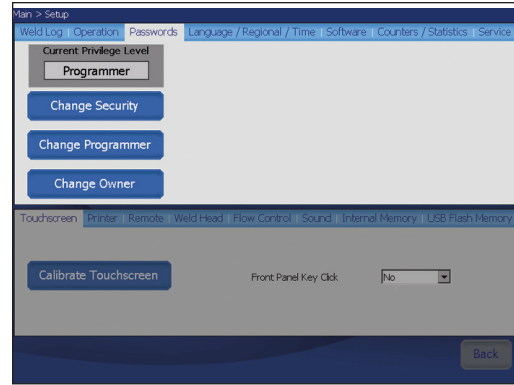

Fig. 43—Current Privilege Level Button

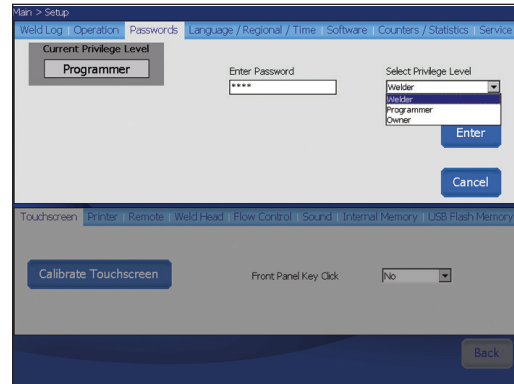

Fig. 44—Privilege Level Dropdown Menu

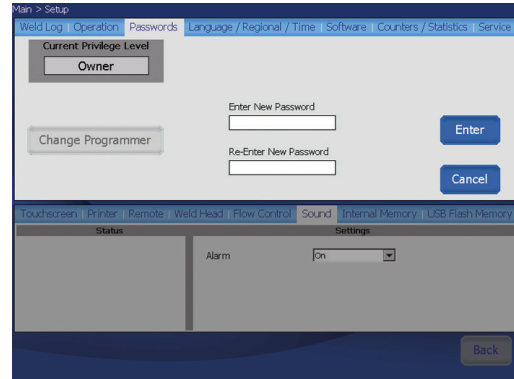

Fig. 45—Setting or Resetting Passwords

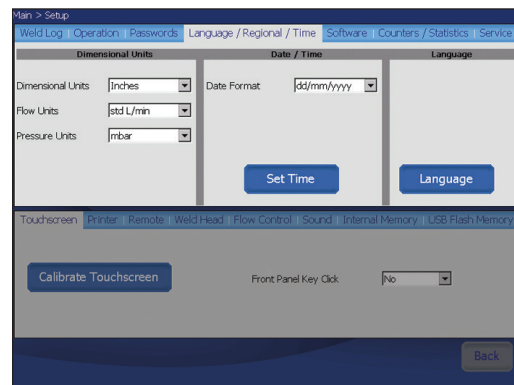

Fig. 46—Language / Regional / Time Tab

Table 15—Setup Lower Section Tabs

Touchscreen	Press Calibrate Touchscreen to recalibrate the cursor position relative to your fingertip. <i>See page 23 for more information about calibrating the touch screen.</i> Press Front Panel Key Click on or off to turn on or off the audible click heard when a button is pressed.
Printer (Fig. 47)	Displays Printer status (paper out, head up) and settings. Use this screen to set the Paper Feed Length (short, medium, long) and Paper Cut (manual, partial, full).
Remote	Displays Remote status (connected, type) and settings. Use this screen to turn the Remote Key Click on or off.
Weld Head	Displays weld head status (head connected, head type).
Flow Control	Allows disabling of the MFC that controls the OD shield gas and turns off disable, operational, and error codes associated with OD shield gas flow.
Sound	Turns the Alarm on or off. When this function is on and a weld error occurs, the audible alarm will sound. The error displays on the Status line and is recorded in the Weld Log.
Internal Memory	Displays the status of the system memory (capacity, used space, free space).
USB Flash Memory	Displays the status of the USB flash drive memory (capacity, used space, free space).

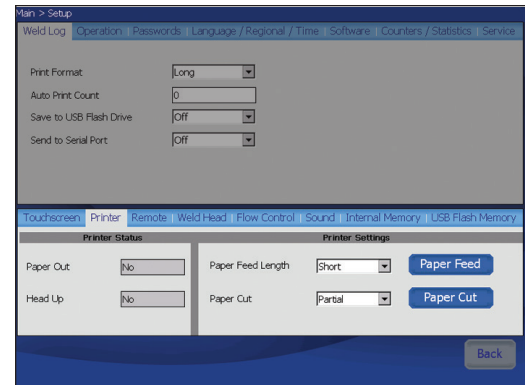

Fig. 47—Printer Tab

NOTICE

Disabling the shield gas flow control allows a weld to be performed without using the M200 power supply internal shield gas flow control. Shield gas is essential to cooling the weld head and shielding the weld zone. Failure to provide an alternative (external) means of shielding can result in weld head and fixture damage.

Passwords

The M200 power supply may be programmed with up to three different password levels to restrict access to different features. One password is available for each level of security. Privileges will be granted based on the password entered at login.

Setting programmer and security passwords is optional. If neither programmer nor security password is set, all users will have programmer rights. All passwords can be set, reset, or removed from their own level or higher.

When all three levels of passwords are set, the following levels of security are enabled:

Security password. The security password gives access to all features and functions of the M200 power supply except:

- Weld parameters cannot be changed outside of the predetermined limits of the weld procedure.
- Software cannot be updated.
- Access to weld procedures is limited to internal memory.
- The programmer and owner passwords cannot be reset.

If a security password is set, but not a programmer password, the security password will allow programmer privileges.

Programmer password. The programmer password gives access to all features and functions of the M200 power supply, except:

- Software cannot be updated.
- The owner password cannot be reset.

If a programmer password is set, but not a security password, either the owner password or the programmer password may be entered to log in to the unit or to use the Lock Out feature.

Owner password. The owner password gives access to all features and functions of the M200 power supply, including software updates.

If any passwords in addition to the owner password are set, the M200 power supply will display a user prompt for a password when it is powered on. Enter and confirm the password and press Privilege Level to view the access granted. Press Enter to use the password and log in to the M200 power supply (Fig. 48).

If you do not set security and programmer passwords:

- The M200 power supply will not prompt for a password when it is powered on.
- Weld procedures can be updated without a password.
- All users will have programmer level rights.
- The Lock Out feature will not function.

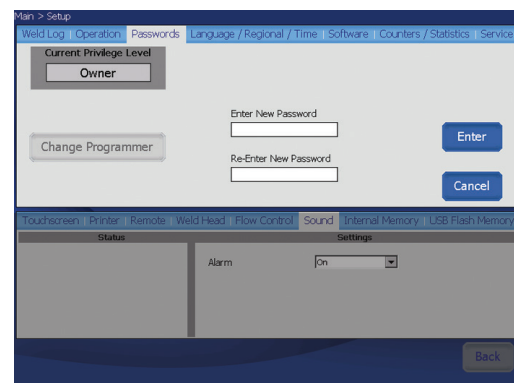

Fig. 48—Login Screen

Remote Pendant

The pendant provides remote operation of the primary power supply controls Start, Stop, Home, and Shield Gas. It also displays power supply status indicators On, Ready, Weld, and Error.

The pendant is attached to the power supply via a cable and the connector labeled Remote on the right side of the power supply (Fig. 49).

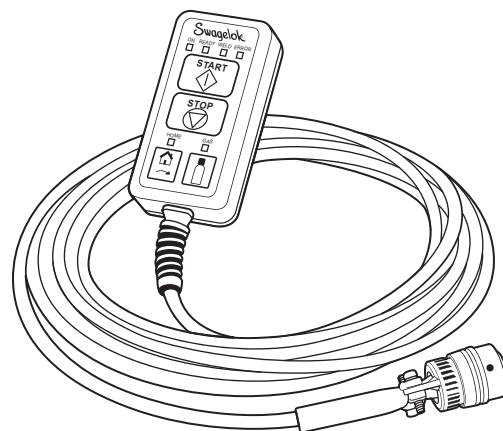

Fig. 49—Remote Pendant

Maintenance

The M200 power supply has no internal serviceable parts and should not be disassembled. The only field-replaceable parts are the printer paper and optional fan filter. Contact your authorized Swagelok representative for any other service needs.



WARNING

Do not attempt to service the M200 power supply. Electrical shock can result.

Printer

Changing Paper

The printer uses thermal paper rolls available from your authorized Swagelok representative. Standard thermal paper rolls available at most office supply stores may also be used.

To change the paper roll:

1. Push down on latch to open printer door (Fig. 50).
2. Remove the old paper roll (Fig. 51).

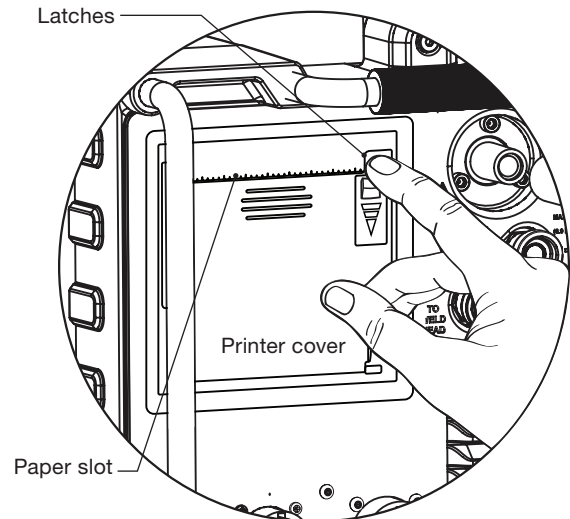

Fig. 50—Opening the Printer Cover

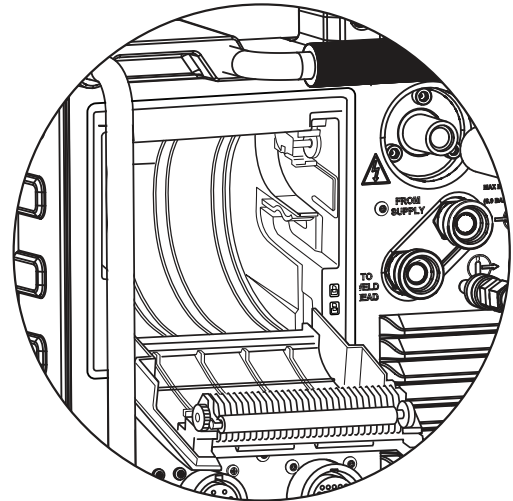

Fig. 51—Remove Paper Roll



CAUTION

The cutting edge is sharp. Do not touch it or injury may result.

3. Place new paper roll into printer as shown (Fig. 52). Ensure paper roll is inserted so that the paper feeds from the top
4. Hold the end of the paper and close the printer cover. The paper needs to be aligned in the center (Fig. 53).
5. When closing the printer door, use two fingers and press the center of the door just below the paper. This insures that the printer door is fully closed (Fig. 54).

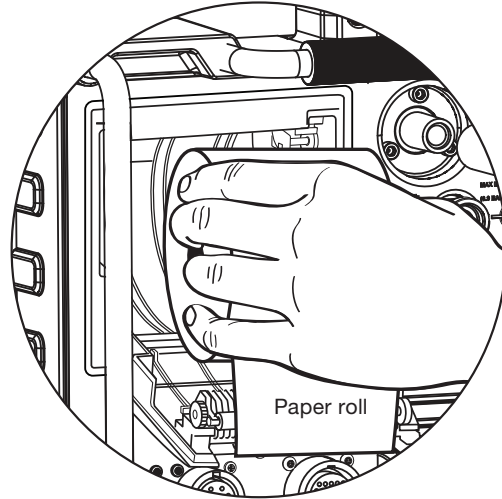

Fig. 52—Loading the Paper Roll

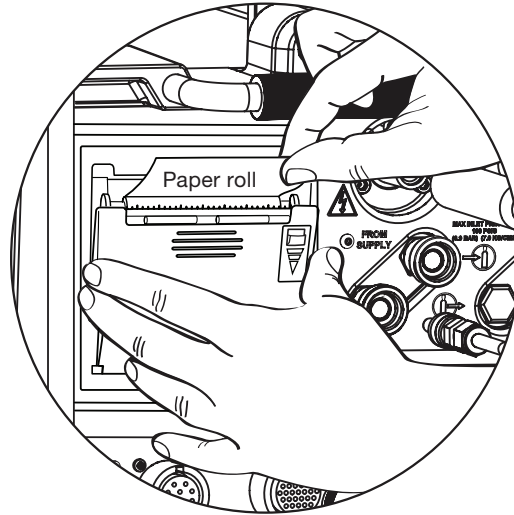

Fig. 53—Aligning the paper in the center

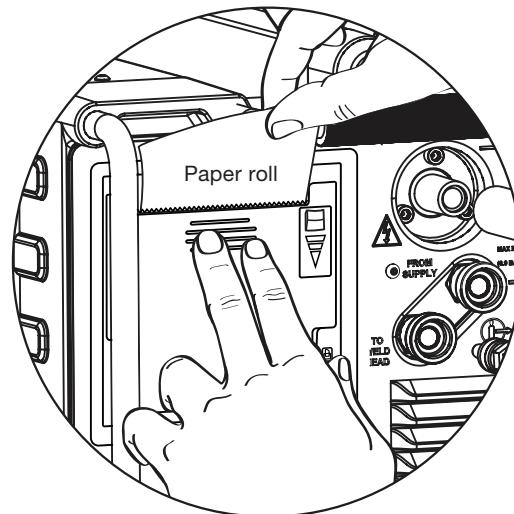

Fig. 54—Closing the printer door

Installing and Replacing the Optional Fan Filter

The filter is not required for normal power supply operation. It can be purchased for use in dusty environments.

To install or replace the optional fan filter in the M200 power supply (Fig. 55):

1. Turn off the power to the M200 power supply.
2. Press the **latch** at the side of the **fan housing door** and pull it open.
3. Remove the old **filter** and press the new filter into the cover.
4. Close the fan housing door.

Failure to clean or replace the fan filter periodically could result in excessive heat buildup. Contact your authorized Swagelok representative for replacement filters.

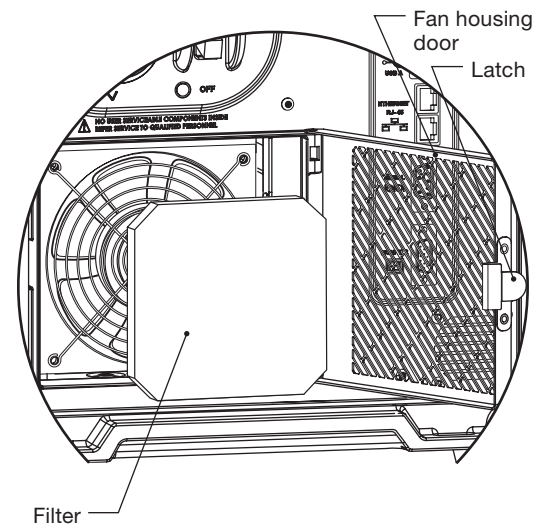

Fig. 55—Installing and Replacing the Optional Fan Filter

Weld Parameter Development

Weld parameters are the values used to create a weld procedure. The shape and duration of the output current waveform—a graphical representation of the weld procedure—is determined by the weld parameter settings. Figure 56 shows the waveform typical parameters generate during the course of a multilevel weld. The weld parameter settings are:

Parameter	1	2	3	4
High Amps, A	71.7	68.1	64.5	60.9
Low Amps, A	21.7	21.7	21.7	21.7
Weld Time, s	5.0	5.0	5.0	5.0
Ramp Time, s	0.0	0.0	0.0	0.0
Pulse Rate, Hz	4.0	4.0	4.0	4.0
High Amps Width, %	28.0	28.0	28.0	28.0
High Amps Speed, rpm	3.5	3.5	3.5	3.5
Low Amps Speed, rpm	3.5	3.5 </td <td>3.5</td> <td>3.5</td>	3.5	3.5
Average Amps, A	35.7	34.7	33.7	32.7

During a typical weld, the M200 power supply pulses between High Amps and Low Amps. In this case, the current pulses between the high and the low levels four times per second. The current is at the high level 28 % of the time and at the low level 72 % of the time.

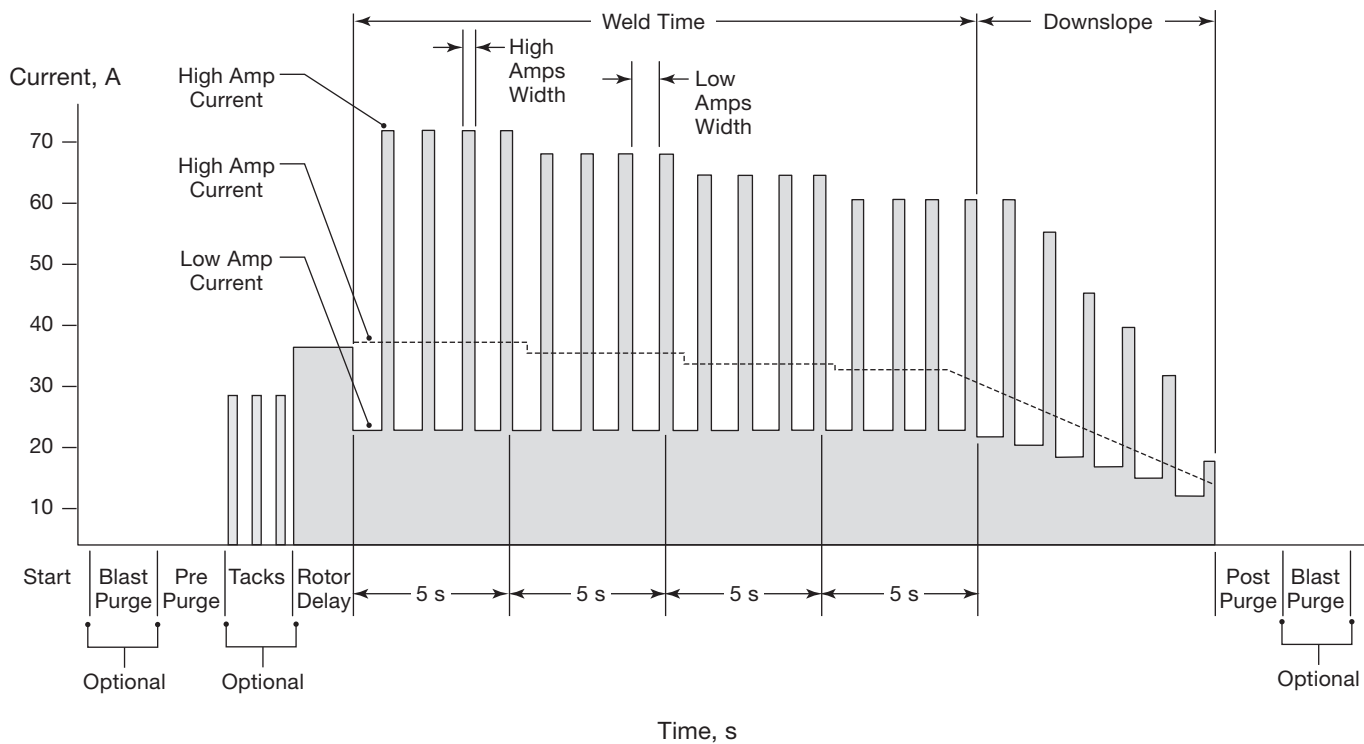

Fig. 56—Multilevel Weld Current Waveform

Weld Parameter Changes

High Amps, High Amps Width, and Rotor Speed affect the depth of penetration of the weld. The control of these parameters allows fine tuning of the weld penetration level.

Creating a Weld Procedure Guideline

A Weld Procedure Guideline is the initial set of weld parameters used to program the M200 power supply for a specific weld job. The M200 power supply Auto Create feature is recommended to generate the weld procedure, but for instances where the work piece dimensions are not available in the M200 power supply dropdown boxes or manual program creation is desired, the *Weld Procedure Guideline Worksheets* starting on page 56 can be used to determine work specifications and calculate weld parameters.

Butt Welds

The *Butt Weld Procedure Guideline Worksheets* can be used to generate procedure guidelines for butt-to-butt tube and pipe welds, as well as other cylindrical butt-to-butt welds.

The worksheets (fractional, page 56; metric, page 60) go through the steps required to create a Weld Procedure Guideline. Alongside each step is an example to show how an actual parameter value would be created. Both examples are based on 316L tube-to-tube fusion butt welds. The example fractional tube size is 1/2 in. OD and 0.049 in. wall thickness. The example metric tube size is 12.0 mm OD and 1.0 mm wall thickness.

Note: Any procedure generated manually using the Weld Procedure Guideline Worksheets or generated automatically by the M200 power supply is only a guideline. The final weld quality depends on the operator's welding experience and on the proper use of welding techniques. Parameter adjustments will need to be made and weld quality verified in accordance with the user's quality standards.

Weld Procedure Guideline Worksheets

Table 16—Fractional Butt Weld Procedure Guideline Worksheet

Step	Parameter	Example Based on 1/2 in. × 0.049 in. Tube-Tube 316LV	Entry Screen
1	Programmer _____	Joe Welder _____	Weld / Information / Programmer box
2	Joint Type <i>Example Tube to tube (Tube–Tube)</i> Side 1 _____ <i>Tube to auto tube weld (Tube–ATW)</i> Side 2 _____ <i>Tube to auto socket weld (Tube–Socket)</i>	Side 1 Tube _____ Side 2 Tube _____	Weld / Weld Setup / Joint field
3	Material Side 1 _____ ; Side 2 _____	Side 1 316LV _____ Side 2 316LV _____	Weld / Weld Setup / Joint field
4	Work piece diameter Diameter (Side 1) = _____ ; Diameter (Side 2) = _____ <i>For future calculations:</i> OD = _____ (<i>use larger of Side 1 and Side 2</i>)	Side 1 0.5 _____ in. Side 2 0.5 _____ in. 0.5 in.	Weld / Weld Setup / Joint field
5	Wall thickness Wall (Side 1) = _____ (<i>use socket wall thickness for socket weld</i>) Wall (Side 2) = _____ <i>For future calculations:</i> Wall = _____ (<i>use larger of side 1 and side 2</i>)	Side 1 0.049 _____ in. Side 2 0.049 _____ in. 0.049 in.	Weld / Weld Setup / Joint field
6	Head (weld head model) _____	5H _____	Weld / Weld Setup / Setup field
7	Electrode (part number) _____ (<i>see weld head user's manual</i>)	CWS-C.040-.555-P _____	Weld / Weld Setup / Setup field
8	Arc Gap (<i>for socket welds, 0.010 in. is suggested</i>) _____ (<i>see Table 25, page 82 for other weld styles</i>)	0.035 _____ in.	Weld / Weld Setup / Setup field
9	Arc Gauge _____ (<i>see weld head user's manual</i>)	0.907 _____ in.	Weld / Weld Setup / Setup field
10	Shield Gas _____ ID Gas _____	Argon _____ Argon _____	Weld / Purge Setup / Gas Type field
11	PrePurge Time _____ <i>Continuous purge suggested for micro weld heads; minimum 20 second purge for all other heads</i> PostPurge Time _____ <i>20 seconds suggested purge time; more than 20 seconds for high Average Amp welds</i>	20 _____ s 20 _____ s	Weld / Purge Setup / Normal Purge field
12	Shield Flow _____ (<i>see Table 26, page 82</i>)	20 _____ std ft ³ /h	Weld / Purge Setup / Normal Purge field
13	ID Flow _____ (<i>see Table 27, page 83</i>) ID Pressure _____ (<i>see Table 27, page 83</i>)	15 _____ std ft ³ /h 1.3 _____ in. water	Weld / Purge Setup / Normal Purge field

Table 16—Fractional Butt Weld Procedure Guideline Worksheet

Step	Parameter	Example Based on 1/2 in. × 0.049 in. Tube-Tube 316LV	Entry Screen
14	For future calculations: High Amp current factors F_1 , F_2 , and F_3 (see Table 29, page 84) $F_1 = \underline{\hspace{1cm}}$; $F_2 = \underline{\hspace{1cm}}$; $F_3 = \underline{\hspace{1cm}}$	$F_1 = 2400$ $F_2 = 0$ $F_3 = 2.3$	
15	For future calculations: Width = $(320 \times \text{Wall [step 5]} + 12) \div 100 = \underline{\hspace{1cm}}$ $(320 \times \underline{\hspace{1cm}} + 12) \div 100 = \underline{\hspace{1cm}}$	$(320 \times 0.049 + 12) \div 100$ $= 0.28$	
16	High Amps for Level 1 = $(F_1 [\text{step 14}] \times \text{Wall [step 5]} + F_2) \div (F_3 \times \text{Width [step 15]} + 1) = \underline{\hspace{1cm}}$ $(\underline{\hspace{1cm}} \times \underline{\hspace{1cm}} + \underline{\hspace{1cm}}) \div (\underline{\hspace{1cm}} \times \underline{\hspace{1cm}} + 1) = \underline{\hspace{1cm}}$	$(2400 \times 0.049 + 0) \div (2.3 \times 0.28 + 1) = 71.5$ A	Weld / Levels (1)
17	Low Amps for all levels = High Amps _{Level 1} (step 16) $\div (F_3 [\text{step 14}] + 1) = \underline{\hspace{1cm}}$ $\underline{\hspace{1cm}} \div (\underline{\hspace{1cm}} + 1) = \underline{\hspace{1cm}}$	$71.5 \div (2.3 + 1) = 21.7$ A	Weld / Levels (1)
18	For future calculations (do not add columns on screen at this time): Number of levels for multiple level schedule $N_{\text{Levels}} = \underline{\hspace{1cm}}$ (typically 4, allowed range is 1 to 99)	4	
19	For future calculations: Travel speed calculation: Travel speed based on wall thickness $\text{Speed}_{\text{Wall}} = \underline{\hspace{1cm}}$ (See Table 29, page 84) Travel speed based on OD $\text{Speed}_{\text{OD}} = \underline{\hspace{1cm}}$ (See Table 29, page 84) Total travel speed = $(\text{Speed}_{\text{Wall}} + \text{Speed}_{\text{OD}}) \div 2 = \underline{\hspace{1cm}}$ $(\underline{\hspace{1cm}} + \underline{\hspace{1cm}}) \div 2 = \underline{\hspace{1cm}}$	$\text{Speed}_{\text{Wall}} = 6$ in./min $\text{Speed}_{\text{OD}} = 5$ in./min $(6 + 5) \div 2 = 5.5$ in./min	
20	For future calculations: Work piece circumference = OD (step 4) $\times \pi = \underline{\hspace{1cm}}$ $\underline{\hspace{1cm}} \times 3.1416 = \underline{\hspace{1cm}}$	$0.50 \times 3.1416 = 1.571$ in.	
21	High Amps Speed (rpm) for all levels = Total travel speed (step 19) \div Circumference (step 20) $= \underline{\hspace{1cm}}$ $\underline{\hspace{1cm}} \div \underline{\hspace{1cm}} = \underline{\hspace{1cm}}$	$5.5 \div 1.571 = 3.5$ rpm	Weld / Levels (1)
22	Low Amps Speed (rpm) for all levels = Total travel speed (step 19) \div Circumference (step 20) $= \underline{\hspace{1cm}}$ $\underline{\hspace{1cm}} \div \underline{\hspace{1cm}} = \underline{\hspace{1cm}}$	$5.5 \div 1.571 = 3.5$ rpm	Weld / Levels (1)
23	For future calculations: Weld Time total for single pass: Seconds per revolution (spr) = $60 \div$ High/Low Amps speed $= \underline{\hspace{1cm}}$ $60 \div \underline{\hspace{1cm}} = \underline{\hspace{1cm}}$ Additional Weld Time to overlap Level 1 Overlap = $(\text{Wall [step 5]} \times 2) \div (\text{Total travel speed [step 19]} \div 60) = \underline{\hspace{1cm}}$ $(\underline{\hspace{1cm}} \times 2) \div (\underline{\hspace{1cm}} \div 60) = \underline{\hspace{1cm}}$ $\text{Time}_{\text{Total}} = \text{spr} + \text{Overlap} = \underline{\hspace{1cm}}$ $\underline{\hspace{1cm}} + \underline{\hspace{1cm}} = \underline{\hspace{1cm}}$	$60 \div 3.5 = 17.1$ spr $(0.049 \times 2) \div (5.5 \div 60) = 1.1$ s $17.1 + 1.1 = 18.2$ s	

Table 16—Fractional Butt Weld Procedure Guideline Worksheet

Step	Parameter	Example Based on 1/2 in. × 0.049 in. Tube-Tube 316LV	Entry Screen
24	<p>Weld Time for all levels = $\text{Time}_{\text{Total}}$ (step 23) ÷ N_{Levels} (step 18)</p> <p>= _____</p> <p>_____ ÷ _____ = _____</p> <p>Note: Round up to the nearest 0.5 second or whole number, whichever is smaller.</p>	<p>18.2 ÷ 4 = 5.0</p> <p>Note: Weld Time number must always end in ".5" or ".0"</p>	Weld / Levels (1)
25	<p>Pulse Rate for all levels = Total travel speed (step 19) ÷ (30 × Wall [step 5]) = _____</p> <p>_____ ÷ (30 × _____) = _____</p> <p>Note: Round up to nearest whole number.</p> <p>If Weld Time ends in ".5" and Pulse Rate is odd number^①</p> <p>Pulse Rate for all levels = Pulse Rate + 1 (forces Pulse Rate × Weld Time to be a whole number)</p> <p>_____ + 1 = _____</p>	<p>5.5 ÷ (30 × 0.049) = 4</p> <p>Note: If Weld Time ends in ".5," Pulse Rate must be even to prevent a skip between levels (Weld Time ends in ".0")</p>	Weld / Levels (1)
26	<p>High Amps Width = 320 × Wall (step 5) + 12 = _____</p> <p>320 × _____ + 12 = _____</p> <p>Note: Round up to nearest whole number.</p>	<p>320 × 0.049 + 12 = 28</p>	Weld / Levels (1)
27	<p>Add additional level columns now (step 18)</p> <p>Multiple level current factor</p> <p>$F_{\text{Level}} = (\text{High Amps}_{\text{Level 1}}$ [step 16] × 0.2) ÷ N_{Levels} (step 18)</p> <p>= _____</p> <p>(_____ × 0.2) ÷ _____ = _____</p> <p>High Amps for Level 2 = High Amps_{Level 1} (step 16) - F_{Level}</p> <p>= _____</p> <p>_____ - _____ = _____</p>	<p>(71.5 × 0.2) ÷ 4 = 3.6</p> <p>71.5 - 3.6 = 67.9 A</p>	Weld / Levels (4)
28	<p>High Amps for Level 3 = High Amps_{Level 2} (step 27) - F_{Level} (step 27) = _____</p> <p>_____ - _____ = _____</p>	<p>67.9 - 3.6 = 64.3 A</p>	Weld / Levels (4)
29	<p>High Amps for Level 4 = High Amps_{Level 3} (step 28) - F_{Level} (step 27) = _____</p> <p>_____ - _____ = _____</p>	<p>64.3 - 3.6 = 60.7 A</p>	Weld / Levels (4)
30	<p>Delay Current = (High Amps_{Level 1} [step 16] × Width [step 15]) + (Low Amps [step 17] × [1 - Width]) = _____</p> <p>(_____ × _____) + (_____ × [1 - _____]) = _____</p>	<p>(71.5 × 0.28) + (21.7 × [1 - 0.28]) = 35.6 A</p>	Weld / General / Start field
31	<p>For Wall ≤ 0.083 in.</p> <p>Rotor Delay Time = Wall (step 5) × 40 = _____</p> <p>_____ × 40 = _____</p> <p>For Wall > 0.083 in.</p> <p>Rotor Delay Time = Overlap (step 23)</p> <p>= _____</p>	<p>0.049 × 40 = 2.0 s</p> <p>(Wall < 0.083 in.)</p>	Weld / General / Start field

① This step, in conjunction with rounding the Weld Time to the nearest 0.5 second, prevents consecutive periods of low amperage output during the transition from one level to the next. This would be observed as skipping between weld levels. Note from Fig. 56, page 54, each level begins with the Low Amps period of the pulse cycle. The Weld Time multiplied by the Pulse Rate:

Weld Time × Pulse Rate, that is, the number of seconds per level × cycles per second must equal a whole number of cycles per level to ensure each level ends with a complete Low to High Amps cycle before beginning the next level.

Table 16—Fractional Butt Weld Procedure Guideline Worksheet

Step	Parameter	Example Based on 1/2 in. × 0.049 in. Tube-Tube 316LV	Entry Screen
32	<p>Downslope = Time_{Total} (step 23) ÷ constant = _____</p> <p>Constant: OD < 0.5 in. = 1.25 0.5 < OD < 1.0 in. = 2.5 1.0 in. ≤ OD = 15</p> <p>_____ ÷ = _____</p> <p>If Downslope < 10 ÷ Pulse Rate (step 25) then Downslope = 10 ÷ Pulse Rate = _____</p> <p>(forces a minimum of 10 pulses for Downslope)</p>	<p>18.2 ÷ 2.5 = 7.3 s (0.50 in. ≤ OD < 1.0 in.)</p> <p>10 ÷ 4 = 2.5 (7.3 > 2.5)</p>	Weld / General / Finish field

NOTICE
When welding 1/2 in. outside diameter with the 8 MRH weld head, use a single-pass (one revolution) weld procedure only.

Table 17— Metric Butt Weld Procedure Guideline Worksheet

Step	Parameter	Example Based on 12.0 × 1.0 mm Tube-Tube 316LV	Entry Screen
1	Programmer [redacted]	Joe Welder [redacted]	Weld / Information / Programmer box
2	Joint Type Example Tube to tube (Tube-Tube) Side 1 [redacted] Tube to auto tube weld (Tube-ATW) Side 2 [redacted] Tube to auto socket weld (Tube-Socket)	Side 1 Tube [redacted] Side 2 Tube [redacted]	Weld / Weld Setup / Joint field
3	Material Side 1 [redacted] ; Side 2 [redacted]	Side 1 316LV [redacted] Side 2 316LV [redacted]	Weld / Weld Setup / Joint field
4	Work piece diameter Diameter (Side 1) = [redacted] ; Diameter (Side 2) = [redacted] For future calculations: OD = _____ (use larger of Side 1 and Side 2)	Side 1 12.0 [redacted] mm Side 2 12.0 [redacted] mm 12.0 mm	Weld / Weld Setup / Joint field
5	Wall thickness Wall (Side 1) = [redacted] (use socket wall thickness for socket weld) Wall (Side 2) = [redacted] For future calculations: Wall = _____ (use larger of side 1 and side 2)	1.0 [redacted] mm 1.0 [redacted] mm 1.0 mm	Weld / Weld Setup / Joint field
6	Head (weld head model) [redacted]	5H [redacted]	Weld / Weld Setup / Setup field
7	Electrode (part number) [redacted] (see weld head user's manual)	CWS-C.040-.555-P [redacted]	Weld / Weld Setup / Setup field
8	Arc Gap (for socket welds, 0.25 mm is suggested) [redacted] (see Table 25, page 82 for other weld styles)	0.76 [redacted] mm	Weld / Weld Setup / Setup field
9	Arc Gauge [redacted] (see weld head user's manual)	22.56 [redacted] mm	Weld / Weld Setup / Setup field
10	Shield Gas [redacted] ID Gas [redacted]	Argon [redacted] Argon [redacted]	Weld / Purge Setup / Gas Type field
11	PrePurge Time Continuous purge suggested for micro weld heads; minimum 20 second purge for all other heads [redacted] PostPurge Time 20 seconds suggested purge time; more than 20 seconds for high average amp welds [redacted]	20 [redacted] s 20 [redacted] s	Weld / Purge Setup / Normal Purge field
12	Shield Flow [redacted] (see Table 26, page 82)	10.0 [redacted] std L/min	Weld / Purge Setup / Normal Purge field
13	ID Flow [redacted] (see Table 28, page 83) ID Pressure [redacted] (see Table 28, page 83)	7.0 [redacted] std L/min 3.2 [redacted] mbar	Weld / Purge Setup / Normal Purge field

Table 17— Metric Butt Weld Procedure Guideline Worksheet

Step	Parameter	Example Based on 12.0 × 1.0 mm Tube-Tube 316LV	Entry Screen
14	For future calculations: High Amp current factors F ₁ , F ₂ , and F ₃ (see Table 30, page 84) F ₁ = ____ ; F ₂ = ____ ; F ₃ = ____	F ₁ = 84 F ₂ = 0 F ₃ = 2.3	
15	For future calculations: Width = (12.8 × Wall [step 5] + 12) ÷ 100 = ____ (12.8 × ____ + 12) ÷ 100 = ____	(12.8 × 1.0 + 12) ÷ 100 = 0.25	
16	High Amps for Level 1 = (F ₁ [step 14] × Wall [step 5] + F ₂) ÷ (F ₃ × Width [step 15] + 1) = ____ (____ × ____ + ____) ÷ (____ × ____ + 1) = ____	(84 × 1.0 + 0) ÷ (2.3 × 0.25 + 1) = 53.3 A	Weld / Levels (1)
17	Low Amps for all levels = High Amps _{Level 1} (step 16) ÷ (F ₃ (step 14) + 1) = ____ ____ ÷ (____ + 1) = ____	53.3 ÷ (2.3 + 1) = 16.2 A	Weld / Levels (1)
18	For future calculations (do not add columns on screen at this time): Number of levels for multiple level schedule N _{Levels} = ____ (typically 4, allowed range is 1 to 99)	4	
19	For future calculations Travel speed calculation: Travel speed based on wall thickness Speed _{Wall} = ____ (See Table 30, page 84) Travel speed based on OD Speed _{OD} = ____ (See Table 30, page 84) Total travel speed = (Speed _{Wall} + Speed _{OD}) ÷ 2 = ____ (____ + ____) ÷ 2 = ____	Speed _{Wall} = 178 mm/min Speed _{OD} = 152 mm/min (178 + 152) ÷ 2 = 165 mm/min	
20	For future calculations: Work piece circumference = OD (step 4) × π = ____ ____ × 3.1416 = ____	12.0 × 3.1416 = 37.7 mm	
21	High Amps Speed (rpm) for all levels = Total travel speed (step 19) ÷ Circumference (step 20) = ____ ____ ÷ ____ = ____	165 ÷ 37.7 = 4.38 rpm	Weld / Levels (1)
22	Low Amps Speed (rpm) for all levels = Total travel speed (step 19) ÷ Circumference (step 20) = ____ ____ ÷ ____ = ____	165 ÷ 37.7 = 4.38 rpm	Weld / Levels (1)
23	For future calculations: Weld Time total for single pass: Seconds per revolution (spr) = 60 ÷ High/Low Amps speed = ____ 60 ÷ ____ = ____ Additional Weld Time to overlap Level 1 Overlap = (Wall [step 5]) × 2 ÷ (Total travel speed [step 19] ÷ 60) = ____ (____ × 2) ÷ (____ ÷ 60) = ____ Time _{Total} = spr + Overlap = ____ ____ + ____ = ____	60 ÷ 4.38 = 13.7 spr (1.0 × 2) ÷ (165 ÷ 60) = 0.73 s 13.7 + 0.73 = 14.4 s	
24	Weld Time for all levels = Time _{Total} (step 23) ÷ N _{Levels} (step 18) = ____ ____ ÷ ____ = ____ Note: Round up to the nearest 0.5 second or whole number, whichever is smaller.	14.4 ÷ 4 = 4.0 Note: Weld Time number must always end in ".5" or ".0"	Weld / Levels (1)

Table 17— Metric Butt Weld Procedure Guideline Worksheet

Step	Parameter	Example Based on 12.0 × 1.0 mm Tube-Tube 316LV	Entry Screen
25	<p>Pulse Rate for all levels = Total travel speed (step 19) ÷ (30 × Wall [step 5]) = _____</p> <p>_____ ÷ (30 × _____) = _____</p> <p>Note: Round up to nearest whole number.</p> <p>If Weld Time ends in “.5” and Pulse Rate is odd number^①</p> <p>Pulse Rate for all levels = Pulse Rate + 1 (forces Pulse Rate × Weld Time to be a whole number)</p> <p>_____ + 1 = _____</p>	<p>165 ÷ (30 × 1.0) = 6 _____</p> <p>Note: If Weld Time ends in “.5,” Pulse Rate must be even to prevent a skip between levels</p> <p>(Weld Time ends in “.0”)</p>	Weld / Levels (1)
26	<p>High Amps Width = 12.8 × Wall (step 5) + 12 = _____</p> <p>12.8 × _____ + 12 = _____</p> <p>Note: Round up to nearest whole number.</p>	12.8 × 1.0 + 12 = 25 _____	Weld / Levels (1)
27	<p>Add additional level columns now (step 18)</p> <p>Multiple level current factor</p> $F_{\text{Level}} = (\text{High Amps}_{\text{Level 1}} [\text{step 16}] \times 0.2) \div N_{\text{Levels}} (\text{step 18})$ <p>= _____</p> <p>(_____ × 0.2) ÷ _____ = _____</p> <p>High Amps for Level 2 = High Amps_{Level 1} (step 16) - F_{Level}</p> <p>_____ - _____ = _____</p>	<p>(53.3 × 0.2) ÷ 4 = 2.7</p> <p>53.3 - 2.7 = 50.6 _____ A</p>	Weld / Levels (4)
28	<p>High Amps for Level 3 = High Amps_{Level 2} (step 27) - F_{Level} (step 27) = _____</p> <p>_____ - _____ = _____</p>	50.6 - 2.7 = 47.9 _____ A	Weld / Levels (4)
29	<p>High Amps for Level 4 = High Amps_{Level 3} (step 28) - F_{Level} (step 27) = _____</p> <p>_____ - _____ = _____</p>	47.9 - 2.7 = 45.2 _____ A	Weld / Levels (4)
30	<p>Delay Current = (High Amps_{Level 1} [step 16] × Width [step 15]) + (Low Amps [step 17] × [1 - Width]) = _____</p> <p>(_____ × _____) + (_____ × [1 - _____]) = _____</p>	<p>(53.3 × 0.25) + (16.0 × [1 - 0.25]) = 25.3 _____ A</p>	Weld / General / Start field
31	<p>For Wall ≤ 2.1 mm</p> <p>Rotor Delay Time = Wall (step 5) × 1.6 = _____</p> <p>_____ × 1.6 = _____</p> <p>For Wall > 2.1 mm</p> <p>Rotor Delay Time = Overlap (step 23)</p> <p>= _____</p>	<p>1.0 × 1.6 = 1.6 _____ s</p> <p>(Wall < 2.1 mm)</p>	Weld / General / Start field

① This step, in conjunction with rounding the Weld Time to the nearest 0.5 second, prevents consecutive periods of low amperage output during the transition from one level to the next. This would be observed as skipping between weld levels. Note from Fig. 56, page 54, each level begins with the Low Amps period of the pulse cycle. The Weld Time multiplied by the Pulse Rate:

Weld Time × Pulse Rate, that is, the number of seconds per level × cycles per second must equal a whole number of cycles per level to ensure each level ends with a complete Low to High Amps cycle before beginning the next level.

Table 17— Metric Butt Weld Procedure Guideline Worksheet

Step	Parameter	Example Based on 12.0 × 1.0 mm Tube-Tube 316LV	Entry Screen
32	<p>Downslope = Time_{Total} (step 23) ÷ constant = _____</p> <p>Constant: OD < 12.7 mm = 1.25 12.7 < OD < 25.4 mm = 2.5 25.4 mm ≤ OD = 15</p> <p>_____ ÷ = _____</p> <p>If Downslope < 10 ÷ Pulse Rate (step 25) then Downslope = 10 ÷ Pulse Rate = _____</p> <p>(forces a minimum of 10 pulses for Downslope)</p>	<p>14.4 ÷ 1.25 = 11.5 s (OD < 12.7 mm)</p> <p>10 ÷ 6 = 1.7 (11.5 > 1.7)</p>	<p>Weld / General / Finish field</p>

NOTICE

When welding 12.0 mm. outside diameter with the 8 MRH weld head, use a single-pass (one revolution) weld procedure only.

Automatic Tube (ATW) and Socket Welds

In addition to tube butt welds, the *Weld Procedure Guideline Worksheets* can be used to generate procedure guidelines for automatic tube welds (ATW) and socket welds. These weld joints have features that require some weld parameter values to be different from tube-to-tube butt welds.

ATW Welds

Because the ATW cuff adds material to the weld joint, the wall thickness used for current calculations must be increased to compensate for the additional heat needed. In these cases it is common to add 40 % of the ATW cuff thickness to the fitting wall thickness (Fig. 57).

The M200 power supply Auto Create feature calculates this automatically. The worksheets include this step.

Note: To fixture, center and clamp tube in block first, then push ATW firmly against tube and then clamp

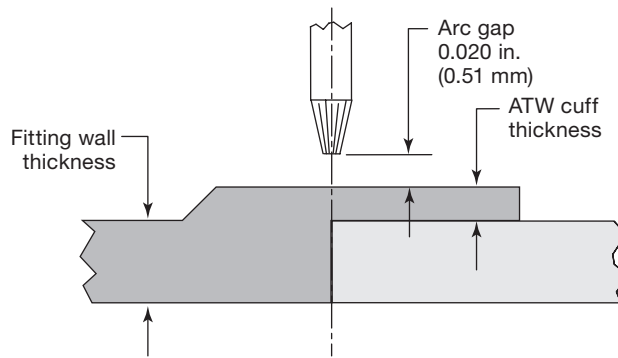

Fig. 57—Automatic Tube Weld Joint

Table 18— Automatic Tube Weld (ATW) Guideline Worksheet

Table 16 (Fractional) or Table 17 (Metric) Step	Parameter	Example Based on 1/2 in. × 0.049 in. (Fractional) or 12.0 × 1.0 mm (Metric) TB-TB 316LV	Entry Screen
	For future calculations: ATW cuff thickness ATW _{Cuff} = _____ (see part drawing)	Fractional tubing: ATW _{Cuff} = 0.025 in. Metric tubing: ATW _{Cuff} = 0.6 mm	
4	For future calculations: ATW adjusted OD = (ATW _{Cuff} × 2) + OD = _____ (_____ × 2) + _____ = _____	Fractional tubing: (0.025 × 2) + 0.5 = 0.55 in. Metric tubing: (0.6 × 2) + 12.0 = 13.2 mm	
5	For future calculations: ATW cuff thickness ATW _{Cuff} = _____ (see Fig. 57) ATW adjusted wall thickness = ATW _{Cuff} × 0.40 + Wall = _____ _____ × 0.40 + _____ = _____	Fractional tubing: ATW _{Cuff} = 0.025 in. 0.025 × 0.40 + 0.049 = 0.059 in. Metric tubing: ATW _{Cuff} = 0.6 mm 0.6 × 0.40 + 1.0 = 1.24 mm	

Socket Welds

All socket welds use a single-pass technique. The arc gap and electrode offset parameters are referenced from the socket. The arc gap is 0.010 in. (0.25 mm) from the socket OD for all sizes, and the offset is 0.015 in. (0.38 mm) from the socket face (Fig. 58). Adjustments may be necessary.

Note: To fixture, push socket face against centering gauge and a 0.015 in. (0.38 mm) offset spacer (e.g. feeler gauge). Clamp socket in collets. Push tube to the bottom of the socket then pull it back 1/16 in. (1.5 mm) minimum. Clamp tube.

Note: Start all socket welds between the 11 and 12 o'clock positions to assist the formation of a weld pool.

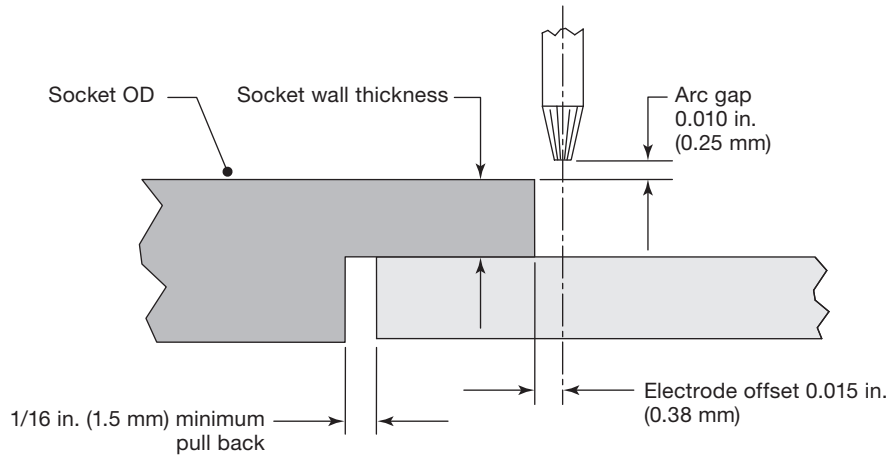

Fig. 58—Socket Weld Joint

Table 19— Socket Weld Guideline Worksheet

Table 16 (Fractional) or Table 17 (Metric) Step	Parameter	Example Based on 1/2 in. × 0.049 in. (Fractional) or 12.0 × 1.0 mm (Metric) TB-TB 316LV	Entry Screen
4	For future calculations: Side 1 diameter = Socket OD OD = _____ (see part drawing)	Fractional tubing 0.73 in. Metric tubing 18.5 mm	
16	High Amps for Level 1 = 1200 × Socket wall thickness = _____ Fractional tubing 1200 × _____ = _____ Metric tubing 47.2 × _____ = _____	Fractional tubing 1200 × 0.115 = 138.0 A Metric tubing 47.2 × 3.2 = 151.0 A	Weld / Levels (1)
17	Low Amps = 0.33 × High Amps _{Level 1 (step 16)} = _____ 0.33 × _____ = _____	Fractional tubing 0.33 × 138.0 = 45.5 A Metric tubing 0.33 × 151.0 = 49.8 A	Weld / Levels (1)
26	High Amps Width = _____ (50 % width suggested)	Fractional tubing 50 % Metric tubing 50 %	Weld / Levels (1)

Advanced Weld Procedure Techniques

The M200 power supply incorporates features that allow adjustments to weld procedures created with using Auto Create, Manual Create, and Single Level Mode programming. These features allow the programmer or owner to adjust the heat input by varying different weld procedure parameters. They also enable optimization with advanced features such as tacking and ramping.

Tacks

Tacks are small welding points that do not penetrate the wall completely. They are used to hold the joint alignment and joint gap during welding.

The M200 power supply will allow up to 20 tacks in Auto Create or Manual Create (Fig. 59). See the *Tack Parameter Guideline Worksheet* below, for use in conjunction with the *Weld Procedure Guideline Worksheets*. Where the two worksheets have common parameters, use the *Tack Parameter Guideline Worksheet* values.

- If tacks break during welding:
 - Increase the time by 0.5 seconds for each tack. This will increase the tack size.
 - Increase the number of tacks.
- If tacks are not fully consumed by the weld, decrease the time by 0.5 seconds for each tack.
- If the weld is to be completed at a later time, tacks must be brushed to remove oxidation before welding. Oxidation can cause weld bead meander if it is not removed. Brushing is not required if the weld is made immediately after tacking.

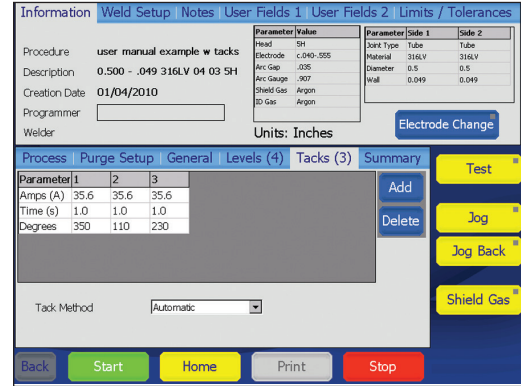

Fig. 59—Tacks Tab

Note: Do not start a weld at a tack position.

NOTICE
Tack programs or programs that include tacks should not be used with Swagelok micro weld heads.

Table 20—Tack Parameter Guideline Worksheet

Step	Parameter	Example Based on 1/2 in. × 0.049 in. (Fractional) or 12.0 × 1.0 mm (Metric) TB-TB 316LV	Entry Screen
1	Number of tacks (<i>up to 20</i>) N_{Tacks} = _____	3	
2	Amps = Delay current (<i>Weld Procedure Guideline Worksheet, step 30</i>)	35.6 A	Weld / Tacks (3)
3	Time <i>Fractional tubing</i> Time = Wall (<i>Weld Procedure Guideline Worksheet, step 5</i>) × 30 = _____ _____ × 30 = _____ <i>Metric tubing</i> Time = Wall (<i>Weld Procedure Guideline Worksheet, step 5</i>) × 1.1 = _____ _____ × 1.1 = _____ <i>If Tack time < Overlap (Weld Procedure Guideline Worksheet, step 23)</i> Time = Overlap = _____	<i>Fractional tubing</i> 0.049 × 30 = 1.5 _____ s <i>Metric tubing</i> 1.0 × 1.1 = 1.1 _____ s — (1.5 > 1.1)	Weld / Tacks (3)
4	Number of degrees between tacks Degrees = 360° ÷ N _{Tacks} = _____ 360° ÷ _____ = _____	360° ÷ 3 = 120 _____ °	Weld / Tacks (3)

Ramp Time

Ramp time is time taken at the beginning of a level to allow a gradual amperage change from the arc start current (for the first level) or the previous level's Low and High Amps settings (for all other levels).

The heat input effect of ramping depends on the levels' current settings directly before and after the ramp (see Fig. 60):

- Ramping from higher current to lower will input more heat into the level by gradually decreasing the current until the Low Amps for the level has been attained.
- Ramping from lower current to higher will slow the heat input into the level by gradually increasing the current until the High Amps for the level has been attained.

Ramp time may be from 0.1 seconds up to taking the entire Weld Time for the level.

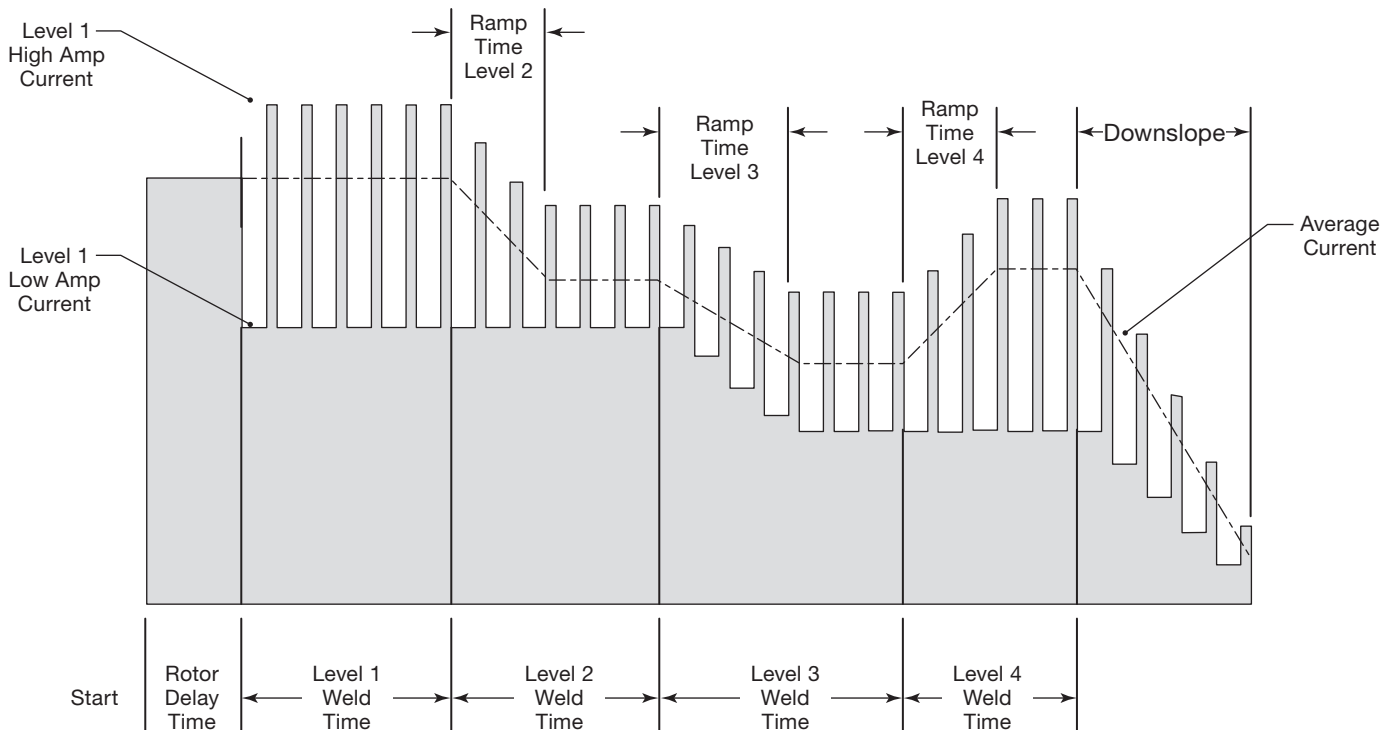

Fig. 60—Ramp Between Levels

Ramping Up in Level 1

Ramping in the first level may be used to slow the startup of the weld to allow controlled heat application, which is required for some materials.

Two methods for gradually adding heat to the material in Level 1 are postponed penetration while welding and added rotor delay time before welding.

Postponed Penetration While Welding

This method adds heat while the rotor advances. This weld most likely will not penetrate until some point during this first level. The overlap time must be increased to ensure an even ID bead width through the whole first level.

See Fig. 61 and the *Level 1 Ramp—Postponed Penetration Guideline Worksheet* below for use in conjunction with the *Weld Procedure Guideline Worksheets*. Where the two worksheets have common parameters, use the *Level 1 Ramp—Postponed Penetration Guideline Worksheet* values/

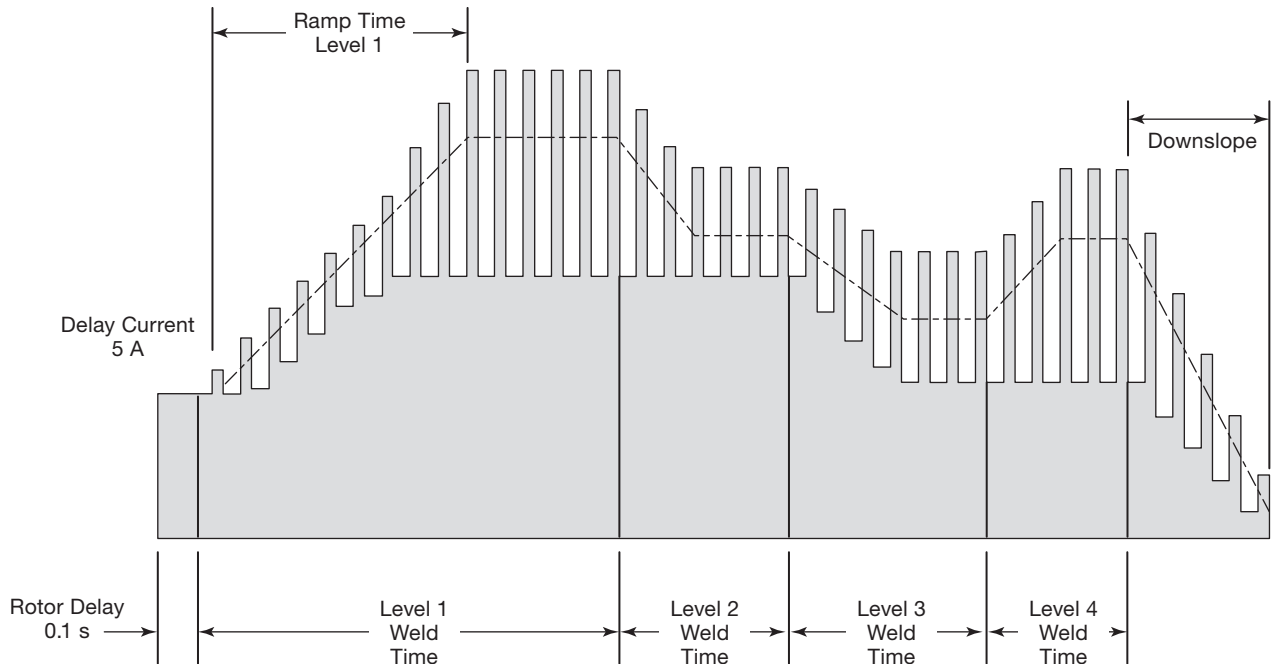

Fig. 61—Postponed Penetration While Welding

Table 21—Level 1 Ramp—Postponed Penetration Guideline Worksheet

Table 16 (Fractional) or Table 17 (Metric) Step	Parameter	Example Based on 1/2 in. × 0.049 in. (Fractional) or 12 mm × 1.0 mm (Metric) Tube-Tube 316LV Increase Level 1 Time with Ramp	Entry Screen
	Ramp Time for Level 1 = _____ <i>Note: Choose a value that is either a whole number or 0.5 second.</i>	3.0 _____ s	Weld / Levels (1)
24	Weld Time for Level 1 Weld Time _{Level 1} = Weld Time (<i>Weld Procedure Guideline Worksheet, step 24</i>) + Ramp Time = _____ = _____ + _____ = _____	<i>Fractional tubing</i> 5.0 + 3.0 = 8.0 _____ s <i>Metric tubing</i> 4.0 + 3.0 = 7.0 _____ s	Weld / Levels (1)
	<i>For future calculations:</i> Percent of Level 1 to overlap for proper ID bead width (range is 0 to 100) Ramp _{Overlap} = _____ Ramp _{Overlap decimal} = Ramp _{Overlap} ÷ 100 = _____ _____ ÷ 100 = _____	40 % 40 ÷ 100 = 0.40	
24b	Weld Time for remaining levels + Ramp overlap Weld Time _{Level 2-4} = {Seconds per revolution (spr) (<i>Weld Procedure Guideline Worksheet, step 23</i>) - (Weld time _{Level 1} [<i>step 24</i>] × [1 - Ramp _{Overlap decimal}])} ÷ (N _{Levels} [<i>Weld Procedure Guideline Worksheet, step 18</i>] - 1) = _____ = { _____ - (_____ × [1 - _____])} ÷ (_____ - 1) = _____ <i>Note: Round up to nearest 0.5 second or whole number, whichever is smaller.</i>	<i>Fractional tubing</i> {17.1 - (8.0 × [1 - 0.40])} ÷ (4 - 1) = 4.1 _____ s <i>Metric tubing</i> {13.7 - (7.0 × [1 - 0.40])} ÷ (4 - 1) = 3.2 _____ s	Weld / Levels (4)
25	If Pulse Rate is an odd number and Weld Time is rounded to nearest 0.5 second Pulse Rate for Level 1 Pulse Rate _{Level 1} = Pulse Rate (<i>Weld Procedure Guideline Worksheet, step 25</i>) + 1 = _____ (<i>forces Pulse Rate × Weld Time to be a whole number</i>) _____ + 1 = _____ If Pulse Rate is an odd number and Weld Time_{Level 2-4} is rounded to nearest 0.5 second Pulse Rate for remaining levels Pulse Rate _{Levels 2 to 4} = Pulse Rate (<i>Weld Procedure Guideline Worksheet, step 22</i>) + 1 = _____ (<i>forces Pulse Rate × Weld Time to be a whole number</i>) _____ + 1 = _____	— (<i>Weld Time for Level 1 is rounded to a whole number</i>) — (<i>Pulse rate from previous calculation is even</i>)	Weld / Levels (4)
30	Delay Current = _____ (5 A or greater)	5 _____ A	Weld / General / Start field
31	Rotor Delay Time = _____ (0.1 second or greater)	0.1 _____ s	Weld / General / Start field

Added Rotor Delay Time Before Welding

This method adds heat before the rotor begins advancing. In this case, full penetration is required before the rotor can advance, but the heat input must be incremental.

See Fig. 62 and the *Level 1 Ramp Added Rotor Delay Time Guideline Worksheet* below, for use in conjunction with the *Weld Procedure Guideline Worksheets*. Where the two worksheets have common parameters, use the *Level 1 Ramp Added Rotor Delay Time Guideline Worksheet* values.

Level 1 becomes a Ramp-up time and Rotor Delay Level. The first weld level will be Level 2. To adjust the penetration:

- Increase the start penetration by increasing the Weld Time of Level 1 or by increasing the weld input current using Adjust from the Weld screen.
- Decrease the start penetration by decreasing the weld input amperage using Adjust from the Weld screen.

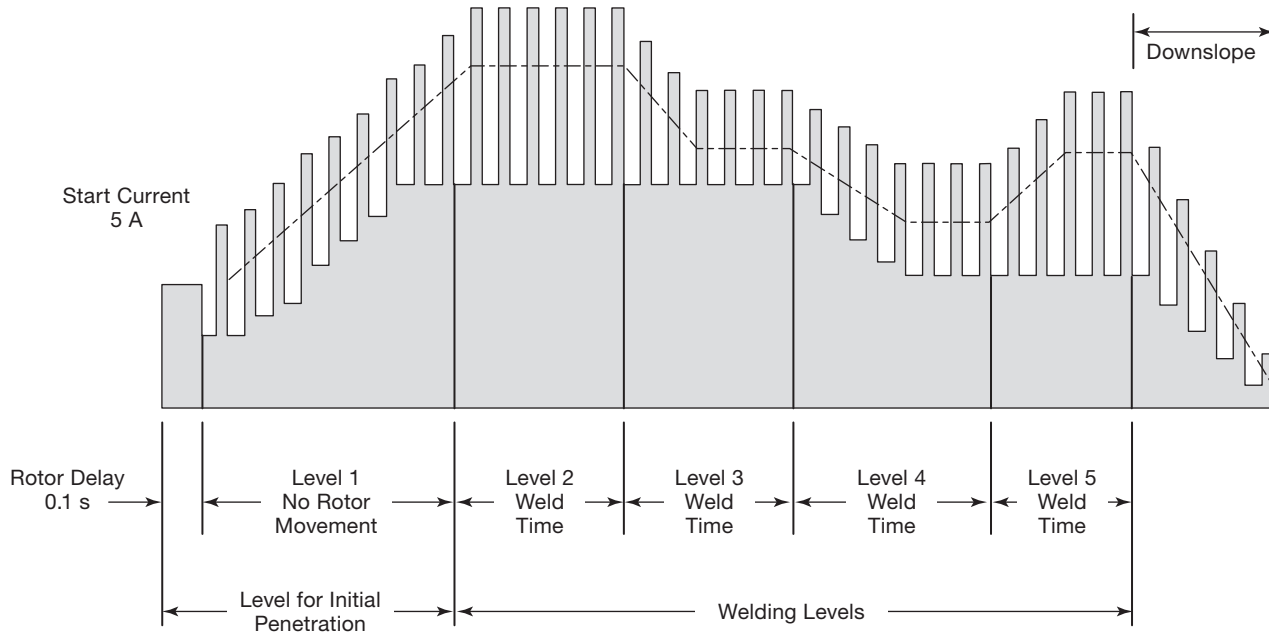

Fig. 62—Added Rotor Delay Time Before Welding

Table 22—Level 1 Ramp Added Rotor Delay Time Guideline Worksheet

Table 16 (Fractional) or Table 17 (Metric) Step	Parameter	Example Based on 1/2 in. × 0.049 in. (Fractional) or 12 mm × 1.0 mm (Metric) Tube-Tube 316LV Hold Rotor Through Level 1	Entry Screen
	Ramp Time for Level 1 = <input type="text"/>	3.0 <input type="text"/> s	Weld / Levels (1)
	For future calculations: Added Rotor Delay Time for full penetration Delay = <input type="text"/> (0.1 second or greater)	1.5 s	
24	Weld Time for Level 1 Weld Time _{Level 1} = Weld Time (Weld Procedure Guideline Worksheet, step 24) + Delay + Ramp Time = <input type="text"/> <input type="text"/> + <input type="text"/> + <input type="text"/> = <input type="text"/> Note: Round up to nearest 0.5 second or whole number, whichever is smaller.	Fractional tubing 5.0 + 1.5 + 3.0 = 9.5 <input type="text"/> s Metric tubing 4.0 + 1.5 + 3.0 = 8.5 <input type="text"/> s	Weld / Levels (1)
25	If Pulse Rate is an odd number and Weld Time is rounded to nearest 0.5 second Pulse Rate for Level 1 only Pulse Rate = Pulse Rate (Weld Procedure Guideline Worksheet, step 25) + 1 = <input type="text"/> (forces Pulse Rate × Weld Time to be a whole number) <input type="text"/> + 1 = <input type="text"/>	— (Pulse Rate from previous calculation is even)	Weld / Levels (1)
21	High Amps Speed in rpm for Level 1 = 0	0 <input type="text"/>	Weld / Levels (1)
22	Low Amps Speed in rpm for Level 1 = 0	0 <input type="text"/>	Weld / Levels (1)
30	Delay Current = <input type="text"/> (5 A or greater)	5 <input type="text"/> A	Weld / General / Start Field
31	Rotor Delay Time = <input type="text"/> (0.1 second or greater)	0.1 <input type="text"/> s	Weld / General / Start field

Step Programs for Multilevel Weld Procedures

A Step Program can be used to refine the control of the weld heat input. A step program is most commonly used when welding thick-walled or larger-diameter tubing to obtain more control over the current or decrease rotor speed.

In a Step Program, the rotor speed is different between the High and Low Amps periods. Decreasing rotor speed increases heat input; increasing rotor speed decreases heat input. The rotor speed may vary from zero to the maximum rotor speed of the weld head being used.

Calculations for Weld Time change significantly for a Step Program. Use the following *Step Program Parameter Guideline Worksheets* to generate the necessary M200 power supply plug-in values.

- The example fractional tube size is 2.0 in. OD and 0.109 in. wall thickness.
- The example metric tube size is 54.0 mm OD and 2.6 mm wall thickness.

Table 23—Fractional Step Program Parameter Guideline Worksheet

Step	Parameter	Example Based on 2.0 in. × 0.109 in. Tube-Tube 316LV	Entry Screen
1	Programmer []	Joe Welder []	Weld / Information / Programmer box
2	Joint Type Example Tube to tube (Tube-Tube) Side 1 [] Tube to auto tube weld (Tube-ATW) Side 2 [] Tube to auto socket weld (Tube-Socket)	Side 1 Tube [] Side 2 Tube []	Weld / Weld Setup / Joint field
3	Material Side 1 [] ; Side 2 []	Side 1 316LV [] Side 2 316LV []	Weld / Weld Setup / Joint field
4	Work piece diameter Diameter (Side 1) = [] ; Diameter (Side 2) = [] For future calculations: OD = _____ (use larger of Side 1 and Side 2)	Side 1 2.0 [] in. Side 2 2.0 [] in. 2.0 in.	Weld / Weld Setup / Joint field
5	Wall thickness Wall (Side 1) = [] (use socket wall thickness for socket weld) Wall (Side 2) = [] For future calculations: Wall = _____ (use larger of side 1 and side 2)	0.109 [] in. 0.109 [] in. 0.109 in.	Weld / Weld Setup / Joint field
6	Head (weld head model) []	40H []	Weld / Weld Setup / Setup field
7	Electrode (part number) [] (see weld head user's manual)	SWS-C.094-2.365 []	Weld / Weld Setup / Setup field
8	Arc Gap (for socket welds, 0.010 in. is suggested) [] (see Table 25, page 82 for other weld styles)	0.060 [] in.	Weld / Weld Setup / Setup field
9	Arc Gauge [] (see weld head user's manual)	0.00 [] in.	Weld / Weld Setup / Setup field
10	Shield Gas [] ID Gas []	Argon [] Argon []	Weld / Purge Setup / Gas Type field
11	PrePurge Time Continuous purge suggested for micro weld heads; minimum 20 second purge for all other heads [] PostPurge Time 20 seconds suggested purge time; more than 20 seconds for high average amp welds []	45 [] s 45 [] s	Weld / Purge Setup / Normal Purge field
12	Shield Flow [] (see Table 26, page 80)	50 [] std ft ³ /h	Weld / Purge Setup / Normal Purge field
13	ID Flow [] (see Table 27, page 83) ID Pressure [] (see Table 27, page 83)	170 [] std ft ³ /h 0.7 [] in. water	Weld / Purge Setup / Normal Purge field

Table 23—Fractional Step Program Parameter Guideline Worksheet

Step	Parameter	Example Based on 2.0 in. × 0.109 in. Tube-Tube 316LV	Entry Screen
14	For future calculations: High Amp current factors F_1 , F_2 , and F_3 (see Table 29, page 84) $F_1 = \underline{\hspace{1cm}}$; $F_2 = \underline{\hspace{1cm}}$; $F_3 = \underline{\hspace{1cm}}$	$F_1 = 460$ $F_2 = 110$ $F_3 = 1.3$	
15	For future calculations: Width = $(320 \times \text{Wall [step 5]} + 12) \div 100 = \underline{\hspace{1cm}}$ $(320 \times \underline{\hspace{1cm}} + 12) \div 100 = \underline{\hspace{1cm}}$	$(320 \times 0.109 + 12) \div 100 = 0.47$	
16	High Amps for Level 1 = $(F_1 \text{ [step 14]} \times \text{Wall [step 5]} + F_2) \div (F_3 \times \text{Width [step 15]} + 1) = \underline{\hspace{1cm}}$ $(\underline{\hspace{1cm}} \times \underline{\hspace{1cm}} + \underline{\hspace{1cm}}) \div (\underline{\hspace{1cm}} \times \underline{\hspace{1cm}} + 1) = \underline{\hspace{1cm}}$	$(460 \times 0.109 + 110) \div (1.3 \times 0.47 + 1) = 99.4$ A	Weld / Levels (1)
17	Low Amps for all levels = High Amps _{Level 1} [step 16] $\div (F_3 \text{ [step 14]} + 1) = \underline{\hspace{1cm}}$ $\underline{\hspace{1cm}} \div (\underline{\hspace{1cm}} + 1) = \underline{\hspace{1cm}}$	$99.4 \div (1.3 + 1) = 43.2$ A	Weld / Levels (1)
18	For future calculations (do not add columns on screen at this time): Number of levels for multiple level schedule $N_{\text{Levels}} = \underline{\hspace{1cm}}$ (typically 4, allowed range is 1 to 99)	4	
19	For future calculations Travel speed calculation: Travel speed based on wall thickness $\text{Speed}_{\text{Wall}} = \underline{\hspace{1cm}}$ (See Table 29, page 84) Travel speed based on OD $\text{Speed}_{\text{OD}} = \underline{\hspace{1cm}}$ (See Table 29, page 84) Total travel speed = $(\text{Speed}_{\text{Wall}} + \text{Speed}_{\text{OD}}) \div 2 = \underline{\hspace{1cm}}$ $(\underline{\hspace{1cm}} + \underline{\hspace{1cm}}) \div 2 = \underline{\hspace{1cm}}$	$\text{Speed}_{\text{Wall}} = 2.3$ in./min $\text{Speed}_{\text{OD}} = 2$ in./min $(2.3 + 2) \div 2 = 2.15$ in./min	
20	For future calculations: Work piece circumference = OD (step 4) $\times \pi = \underline{\hspace{1cm}}$ $\underline{\hspace{1cm}} \times 3.1416 = \underline{\hspace{1cm}}$	$2.0 \times 3.1416 = 6.283$ in.	
21	High Amps Speed (rpm) for all levels = Total travel speed (step 19) \div Circumference (step 20) = $\underline{\hspace{1cm}}$ $\underline{\hspace{1cm}} \div \underline{\hspace{1cm}} = \underline{\hspace{1cm}}$	$2.15 \div 6.283 = 0.34$ rpm	Weld / Levels (1)
22	Low Amps Speed (rpm) for all levels = Total travel speed (step 19) \div Circumference (step 20) = $\underline{\hspace{1cm}}$ $\underline{\hspace{1cm}} \div \underline{\hspace{1cm}} = \underline{\hspace{1cm}}$	$2.15 \div 6.283 = 0.34$ rpm	Weld / Levels (1)
23	Percentage of standard High and Low Amps speed used for Step program (Range is 0 to 100 %. Both cannot be 0.) High Amps % = $\underline{\hspace{1cm}}$ Low Amps % = $\underline{\hspace{1cm}}$ High Amps Speed = $(\text{High Amps \%} \times \text{High Amps Speed [step 21]}) \div 100 = \underline{\hspace{1cm}}$ $(\underline{\hspace{1cm}} \times \underline{\hspace{1cm}}) \div 100 = \underline{\hspace{1cm}}$ Low Amps Speed = $(\text{Low Amps \%} \times \text{Low Amps Speed [step 22]}) \div 100 = \underline{\hspace{1cm}}$ $(\underline{\hspace{1cm}} \times \underline{\hspace{1cm}}) \div 100 = \underline{\hspace{1cm}}$ Note: Round speed to 2 decimal places.	75 % 100 % $(75 \times 0.34) \div 100 = 0.26$ rpm $(100 \times 0.34) \div 100 = 0.34$ rpm	Weld / Levels (1)

Table 23—Fractional Step Program Parameter Guideline Worksheet

Step	Parameter	Example Based on 2.0 in. × 0.109 in. Tube-Tube 316LV	Entry Screen
24	<p>For future calculations: Weld Time total for single pass: Average speed = (High Amp Speed [step 23] × Width [step 15]) + [Low Amps Speed [step 23] × (1 - Width)] = ____ rpm Seconds per revolution (spr) = 60 ÷ Average speed = ____ 60 ÷ ____ = ____ Average Speed = Average speed (rpm) × Circumference (step 20) = ____ in./min Additional Weld Time to overlap Level 1 Overlap = (Wall (step 5) × 2) ÷ (Average speed (in./min) ÷ 60) = ____ (____ × 2) ÷ (____ ÷ 60) = ____ Time_{Total} = spr + Overlap = ____ ____ + ____ = ____</p>	<p>(0.26 × 0.47) + [0.34 × (1 - 0.47)] = 0.30 60 ÷ 0.30 = 200.0 spr 0.30 × 6.283 = 1.88 in. / min (0.109 × 2) ÷ (1.88 ÷ 60) = 7.0 s 200.0 + 7.0 = 207.0 s</p>	
25	<p>Weld Time for all levels = Time_{Total} (step 24) ÷ N_{Levels} (step 18) = ____ ____ ÷ ____ = ____ Note: Round up to the nearest 0.5 second or whole number, whichever is smaller.</p>	<p>207.0 ÷ 4 = 52.0 Note: Weld Time number must always end in ".5" or ".0"</p>	Weld / Levels (1)
26	<p>Pulse Rate for all levels = Total travel speed (step 19) ÷ (30 × Wall [step 5]) = ____ ____ ÷ (30 × ____) = ____ Note: Round up to nearest whole number. If Weld Time ends in ".5" and Pulse Rate is an odd number^① Pulse Rate for all levels = Pulse Rate + 1 (forces Pulse Rate × Weld Time to be a whole number) ____ + 1 = ____</p>	<p>2.15 ÷ (30 × 0.109) = 1 Note: If Weld Time ends in ".5," Pulse Rate must be even to prevent a skip between levels (Weld Time ends in ".0")</p>	Weld / Levels (1)
27	<p>High Amps Width = 320 × Wall (step 5) + 12 = ____ 320 × ____ + 12 = ____ Note: Round up to nearest whole number.</p>	<p>320 × 0.109 + 12 = 47</p>	Weld / Levels (1)
28	<p>Add additional level columns now (step 18) Multiple level current factor F_{Level} = (High Amps_{Level 1} [step 16] × 0.2) ÷ N_{Levels} [step 18] = ____ (____ × 0.2) ÷ ____ = ____ High Amps for Level 2 = High Amps_{Level 1} (step 16) - F_{Level} = ____ ____ - ____ = ____</p>	<p>(99.4 × 0.2) ÷ 4 = 5.0 99.4 - 5.0 = 94.4 A</p>	Weld / Levels (4)
29	<p>High Amps for Level 3 = High Amps_{Level 2} (step 28) - F_{Level} (step 28) = ____ ____ - ____ = ____</p>	<p>94.4 - 5.0 = 89.4 A</p>	Weld / Levels (4)
30	<p>High Amps for Level 4 = High Amps_{Level 3} (step 29) - F_{Level} (step 29) = ____ ____ - ____ = ____</p>	<p>89.4 - 5.0 = 84.4 A</p>	Weld / Levels (4)
31	<p>Delay Current = (High Amps_{Level 1} [step 16] × Width [step 15]) + [Low Amps [step 17] × (1 - Width)] = ____ (____ × ____) + [____ × (1 - ____)] = ____</p>	<p>(99.4 × 0.47) + [43.2 × (1 - 0.47)] = 69.6 A</p>	Weld / General / Start field

Table 23—Fractional Step Program Parameter Guideline Worksheet

Step	Parameter	Example Based on 2.0 in. × 0.109 in. Tube-Tube 316LV	Entry Screen
32	<p>For Wall ≤ 0.083 in. Rotor Delay Time = Wall (step 5) × 40 = _____ _____ × 40 = _____</p> <p>For Wall > 0.083 in. Rotor Delay Time = Overlap (step 24) × [Average speed (rpm, step 24)] ÷ High Amps Speed [step 21]) = _____ (_____ × _____) ÷ _____ = _____</p>	<p>7.0 × (0.30 ÷ 0.34) = 6.2 _____ s</p> <p>(Wall > 0.083 in.)</p>	<p>Weld / General / Start field</p>
33	<p>Downslope = Time_{Total} (step 24) ÷ constant = _____</p> <p>Constant: OD < 0.5 in. = 1.25 0.5 < OD < 1.0 in. = 2.5 1.0 in. ≤ OD = 15</p> <p>_____ ÷ _____ = _____</p> <p>If Downslope < 10 ÷ Pulse Rate (step 26) then Downslope = 10 ÷ Pulse Rate = _____</p> <p>(forces a minimum of 10 pulses for Downslope)</p>	<p>207.0 ÷ 15 = 13.8 _____ s (OD > 1.0 in.)</p> <p>10 ÷ 1 = 10 (13.3 > 10)</p>	<p>Weld / General / Finish field</p>

① This step, in conjunction with rounding the Weld Time to the nearest 0.5 second, prevents consecutive periods of low amperage output during the transition from one level to the next. This would be observed as skipping between weld levels. Note from Fig. 56, page 54, each level begins with the Low Amps period of the pulse cycle. The Weld Time multiplied by the Pulse Rate:

Weld Time × Pulse Rate, that is, the number of seconds per level × cycles per second must equal a whole number of cycles per level to ensure each level ends with a complete Low to High Amps cycle before beginning the next level.

Table 24—Metric Step Program Parameter Guideline Worksheet

Step	Parameter	Example Based on 54.0 mm × 2.6 mm Tube-Tube 316LV	Entry Screen
1	Programmer [redacted]	Joe Welder [redacted]	Weld / Information / Programmer box
2	Joint Type Example Tube to tube (Tube–Tube) Side 1 [redacted] Tube to auto tube weld (Tube–ATW) Side 2 [redacted] Tube to auto socket weld (Tube–Socket)	Side 1 Tube [redacted] Side 2 Tube [redacted]	Weld / Weld Setup / Joint field
3	Material Side 1 [redacted] ; Side 2 [redacted]	Side 1 316LV [redacted] Side 2 316LV [redacted]	Weld / Weld Setup / Joint field
4	Work piece diameter Diameter (Side 1) = [redacted] ; Diameter (Side 2) = [redacted] For future calculations: OD = _____ (use larger of Side 1 and Side 2)	Side 1 54.0 [redacted] mm Side 2 54.0 [redacted] mm 54.0 mm	Weld / Weld Setup / Joint field
5	Wall thickness Wall (Side 1) = [redacted] (use socket wall thickness for socket weld) Wall (Side 2) = [redacted] For future calculations: Wall = _____ (use larger of side 1 and side 2)	2.6 [redacted] mm 2.6 [redacted] mm 2.6 mm	Weld / Weld Setup / Joint field
6	Head (weld head model) [redacted]	40H [redacted]	Weld / Weld Setup / Setup field
7	Electrode (part number) [redacted] (see weld head user's manual)	SWS-C.094-2.302 [redacted]	Weld / Weld Setup / Setup field
8	Arc Gap (for socket welds, 0.25 mm is suggested) [redacted] (see Table 25, page 82 for other weld styles)	1.52 [redacted] mm	Weld / Weld Setup / Setup field
9	Arc Gauge [redacted] (see weld head user's manual)	0.00 [redacted] mm	Weld / Weld Setup / Setup field
10	Shield Gas [redacted] ID Gas [redacted]	Argon [redacted] Argon [redacted]	Weld / Purge Setup / Gas Type field
11	PrePurge Time Continuous purge suggested for micro weld heads; minimum 20 second purge for all other heads [redacted] PostPurge Time 20 seconds suggested purge time; more than 20 seconds for high average amp welds [redacted]	45 [redacted] s 45 [redacted] s	Weld / Purge Setup / Normal Purge field
12	Shield Flow [redacted] (see Table 26, page 82)	24 [redacted] std L/min	Weld / Purge Setup / Normal Purge field
13	ID Flow [redacted] (see Table 28, page 83) ID Pressure [redacted] (see Table 28, page 83)	80 [redacted] std L/min 2.5 [redacted] mbar	Weld / Purge Setup / Normal Purge field

Table 24—Metric Step Program Parameter Guideline Worksheet

Step	Parameter	Example Based on 54.0 mm × 2.6 mm Tube-Tube 316LV	Entry Screen
14	For future calculations: High Amp current factors F ₁ , F ₂ , and F ₃ (see Table 30, page 84) F ₁ = ____ ; F ₂ = ____ ; F ₃ = ____	F ₁ = 18 F ₂ = 110 F ₃ = 1.3	
15	For future calculations: Width = (12.8 × Wall [step 5] + 12 ÷ 100) = ____ (12.8 × ____ + 12) ÷ 100 = ____	(12.8 × 2.6 + 12) ÷ 100 = 0.45	
16	High Amps for Level 1 = (F ₁ [step 14] × Wall [step 5] + F ₂) ÷ (F ₃ × Width [step 15] + 1) = ____ (____ × ____ + ____) ÷ (____ × ____ + 1) = ____	(18 × 2.6 + 110) ÷ (1.3 × 0.45 + 1) = 98.9 A	Weld / Levels (1)
17	Low Amps for all levels = High Amps _{Level 1} (step 16) ÷ (F ₃ [step 14] + 1) = ____ ____ ÷ (____ + 1) = ____	98.9 ÷ (1.3 + 1) = 43.0 A	Weld / Levels (1)
18	For future calculations (do not add columns on screen at this time): Number of levels for multiple level schedule N _{Levels} = ____ (typically 4, allowed range is 1 to 99)	4	
19	For future calculations Travel speed calculation: Travel speed based on wall thickness Speed _{Wall} = ____ (See Table 30, page 84) Travel speed based on OD Speed _{OD} = ____ (See Table 30, page 84) Total travel speed = (Speed _{Wall} + Speed _{OD}) ÷ 2 = ____ (____ + ____) ÷ 2 = ____	Speed _{Wall} = 58 mm/min Speed _{OD} = 51 mm/min (58 + 51) ÷ 2 = 54.5 mm/min	
20	For future calculations: Work piece circumference = OD (step 4) × π = ____ ____ × 3.1416 = ____	54.0 × 3.1416 = 169.6 mm	
21	High Amps Speed (rpm) for all levels = Total travel speed (step 19) ÷ Circumference (step 20) = ____ ____ ÷ ____ = ____	54.5 ÷ 169.6 = 0.32 rpm	Weld / Levels (1)
22	Low Amps Speed (rpm) for all levels = Total travel speed (step 19) ÷ Circumference (step 20) = ____ ____ ÷ ____ = ____	54.5 ÷ 169.6 = 0.32 rpm	Weld / Levels (1)
23	Percentage of standard High and Low Amps Speed used for Step program (Range is 0 to 100 %. Both cannot be 0.) High Amps % = ____ Low Amps % = ____ High Amps Speed = (High Amps % × High Amps Speed [step 21]) ÷ 100 = ____ (____ × ____) ÷ 100 = ____ Low Amps Speed = (Low Amps % × Low Amps Speed [step 22]) ÷ 100 = ____ (____ × ____) ÷ 100 = ____ Note: Round speed to 2 decimal places.	75 % 100 % (75 × 0.32) ÷ 100 = 0.24 rpm (100 × 0.32) ÷ 100 = 0.32 rpm	Weld / Levels (1)

Table 24—Metric Step Program Parameter Guideline Worksheet

Step	Parameter	Example Based on 54.0 mm × 2.6 mm Tube-Tube 316LV	Entry Screen
24	<p>For future calculations: Weld Time total for single pass: Average speed = (High Amp Speed [step 23] × Width [step 15]) + [Low Amps Speed [step 23] × (1 - Width)] = ____ rpm Seconds per revolution (spr) = 60 ÷ Average speed = ____ 60 ÷ ____ = ____ Average Speed = Average speed (rpm) × Circumference (step 20) = ____ mm/min Additional Weld Time to overlap Level 1 Overlap = (Wall (step 5) × 2) ÷ (Average speed (mm/min) ÷ 60) = ____ (____ × 2) ÷ (____ ÷ 60) = ____ Time_{Total} = spr + Overlap = ____ ____ + ____ = ____</p>	<p>(0.24 × 0.45) + [0.32 × (1 - 0.45)] = 0.284 60 ÷ 0.284 = 211.3 spr 0.284 × 169.6 = 48.2 mm/min (2.6 × 2) ÷ (48.2 ÷ 60) = 6.5 s 211.3 + 6.5 = 217.8 s</p>	
25	<p>Weld Time for all levels = Time_{Total} (step 24) ÷ N_{Levels} (step 18) = ____ ____ ÷ ____ = ____ Note: Round up to the nearest 0.5 second or whole number, whichever is smaller.</p>	<p>217.8 ÷ 4 = 54.5 Note: Weld Time number must always end in ".5" or ".0"</p>	Weld / Levels (1)
26	<p>Pulse Rate for all levels = Total travel speed (step 19) ÷ (30 × Wall (step 5)) = ____ ____ ÷ (30 × ____) = ____ Note: Round up to nearest whole number. If Weld Time ends in ".5" and Pulse Rate is an odd number^① Pulse Rate for all levels = Pulse Rate + 1 (forces Pulse Rate × Weld Time to be a whole number) ____ + 1 = ____</p>	<p>54.5 ÷ (30 × 2.6) = 1 Note: If Weld Time ends in ".5," Pulse Rate must be even to prevent a skip between levels 1 + 1 = 2</p>	Weld / Levels (1)
27	<p>High Amps Width = 12.8 × Wall (step 5) + 12 = ____ 12.8 × ____ + 12 = ____ Note: Round up to nearest whole number.</p>	<p>12.8 × 2.6 + 12 = 45</p>	Weld / Levels (1)
28	<p>Add additional level columns now (step 18) Multiple level current factor F_{Level} = (High Amps_{Level 1} [step 16] × 0.2) ÷ N_{Levels} (step 18) = ____ (____ × 0.2) ÷ ____ = ____ High Amps for Level 2 = High Amps_{Level 1} (step 16) - F_{Level} = ____ ____ - ____ = ____</p>	<p>(98.9 × 0.2) ÷ 4 = 5.0 98.9 - 5.0 = 93.9 A</p>	Weld / Levels (4)
29	<p>High Amps for Level 3 = High Amps_{Level 2} (step 28) - F_{Level} (step 28) = ____ ____ - ____ = ____</p>	<p>93.9 - 5.0 = 88.9 A</p>	Weld / Levels (4)
30	<p>High Amps for Level 4 = High Amps_{Level 3} (step 29) - F_{Level} (step 28) = ____ ____ - ____ = ____</p>	<p>88.9 - 5.0 = 83.9 A</p>	Weld / Levels (4)
31	<p>Delay Current = (High Amps_{Level 1} [step 16] × Width [step 15]) + [Low Amps [step 17] × (1 - Width)] = ____ (____ × ____) + [____ × (1 - ____)] = ____</p>	<p>(98.9 × 0.45) + [43.0 × (1 - 0.45)] = 68.2 A</p>	Weld / General / Start field

Table 24—Metric Step Program Parameter Guideline Worksheet

Step	Parameter	Example Based on 54.0 mm × 2.6 mm Tube-Tube 316LV	Entry Screen
32	<p>For Wall ≤ 2.1 mm Rotor Delay Time = Wall (step 5) × 1.6 = _____ _____ × 40 = _____</p> <p>For Wall > 2.1 mm Rotor Delay Time = Overlap (step 24) × [Average speed (rpm, step 24) ÷ High Amps Speed (step 21)] = _____ (_____ × _____) ÷ _____ = _____</p>	<p>6.5 × (0.284 ÷ 0.32) = 5.8 s (Wall > 2.1 mm)</p>	Weld / General / Finish field
33	<p>Downslope = Time_{Total} (step 24) ÷ constant = _____ Constant: OD < 12.7 mm = 1.25 12.7 < OD < 25.4 mm = 2.5 25.4 mm ≤ OD = 15 _____ ÷ _____ = _____</p> <p>If Downslope < 10 ÷ Pulse Rate (step 26) then Downslope = 10 ÷ Pulse Rate = _____ (forces a minimum of 10 pulses for Downslope)</p>	<p>217.8 ÷ 15 = 14.5 s (OD > 25.4 mm)</p> <p>10 ÷ 2 = 5 (14.5 > 5)</p>	Weld / General / Finish field

① This step, in conjunction with rounding the Weld Time to the nearest 0.5 second, prevents consecutive periods of low amperage output during the transition from one level to the next. This would be observed as skipping between weld levels. Note from Fig. 56, page 54, each level begins with the Low Amps period of the pulse cycle. The Weld Time multiplied by the Pulse Rate:

Weld Time × Pulse Rate, that is, the number of seconds per level × cycles per second must equal a whole number of cycles per level to ensure each level ends with a complete Low to High Amps cycle before beginning the next level.

Weld Parameter Guideline Worksheet Reference Data

Table 25 —Wall Thickness and Arc Gap

Material Thickness		Arc Gap	
in.	mm	in.	mm
0.010 to 0.020	0,03 to 0,51	0.020	0,51
0.021 to 0.030	0,52 to 0,86	0.025	0,64
0 031 to 0.045	0,87 to 1,17	0.030	0,76
0.046 to 0.055	1,18 to 1,40	0.035	0,89
0.056 to 0.064	1,41 to 1,60	0.045	1,14
0.065 to 0.082	1,61 to 2,03	0.050	1,27
0.083 to 0.154	2,04 to 3,91	0.055	1,40

Table 26—OD Shield Gas Flow Rates (Argon)

Swagelok Weld Head Series	Flow Rate	
	std ft ³ /h	std L/min
4MH	8 to 15	4.0 to 7.1
8HPH	10 to 15	4.7 to 7.1
8MH	15 to 20	7.1 to 9.4
5H	15 to 25	7.1 to 11.8
10H	15 to 25 ^①	7.1 to 11.8 ^①
20H	20 to 40 ^①	9.4 to 18.8 ^①
40H	25 to 50 ^①	12 to 24 ^①

① Set the flow to the higher rate when welding at high current levels.

Table 27—ID Purge Gas Flow Rate and Pressure, Fractional Dimensions

Tube Size in.	Wall Thickness in.	Minimum ID Purge Flow Rate ^① std ft ³ /h	Pressure ^{②③}		Restrictor Size ^④ in.
			inches of water	torr	
1/16	0.015	0.2	7 to 9	13 to 16.8	—
1/8	0.028	1.0	5 to 9	9.3 to 16.8	1/16
1/4	0.035	6.0	2.8 to 3.4	5.2 to 6.3	1/8
3/8	0.035	10	1.5 to 2.5	2.8 to 4.7	1/8
1/2	0.049	15	1.0 to 1.5	1.9 to 2.8	1/4
3/4	0.065	20	0.5 to 1.1	1 to 2	1/4
1	0.065	40	0.5 to 0.7	1 to 1.3	1/4
1 1/2	0.065	90	0.5 to 0.7	1 to 1.3	1/4
2	0.065	170	0.4 to 0.7	0.7 to 1.3	3/8
3	0.065	400	0.2 to 0.5	0.4 to 0.9	1/2
4	0.083	720	0.2 to 0.4	0.4 to 0.7	3/4

① Indicated purge rates are for minimum color line.

② ATW welds and weld ring welds typically require approximately 15 % more purge pressure.

③ Pressures must be adjusted for ID encroachment of 0 to + 10 % of wall thickness at the bottom of the weld.

④ Restrictor sizes are approximate; purge rate and pressure are critical parameters.

Table 28—ID Purge Gas Flow Rate and Pressure, Metric Dimensions

Tube Size mm	Wall Thickness mm	Minimum ID Purge Flow Rate ^① std L/min	Pressure ^{②③}		Restrictor Size ^④ mm
			millimeters of water	mbar	
3	0.8	0.5	130 to 230	12.4 to 22.4	1.5
6	1.0	3.0	71 to 86	7.0 to 8.5	3
10	1.0	5.0	38 to 64	3.7 to 6.2	3
12	1.0	7.0	25 to 38	2.5 to 3.7	6
20	1.5	10	13 to 28	1.2 to 2.7	6
25	1.5	20	13 to 18	1.2 to 2.5	6
38	1.5	43	13 to 18	1.2 to 1.7	6
50	1.5	80	13 to 18	1.0 to 1.7	10
75	1.5	190	5 to 13	0.5 to 1.2	12
100	2.0	340	5 to 13	0.5 to 1.0	20

① Indicated purge rates are for minimum color line.

② ATW welds and weld ring welds typically require approximately 15 % more purge pressure.

③ Pressures must be adjusted for ID encroachment of 0 to + 10 % of wall thickness at the bottom of the weld.

④ Restrictor sizes are approximate; purge rate and pressure are critical parameters.

Note: These tables are for use on butt welds only. If weld head purge rates exceed Swagelok recommendations, the weld bead may meander. For best results, use constant weld head purge between welding cycles.

Table 29—Fractional High Amps Current Factors and Travel Speeds

Wall in.	High Amps Current Factors			Travel Speed in./min	Outside Diameter, in.		
	F1	F2	F3		Nominal Tube Size	Actual in.	Nominal Pipe Size
0.010 to 0.020	1400	0	5.7	10	1/16	0.063 to 0.124	—
0.021 to 0.034	5450	-91	3.3	8	1/8	0.125 to 0.249	—
0.035 to 0.046	2200	0	2.3	7	1/4	0.250 to 0.374	—
0.047 to 0.055	2400	0	2.3	6	3/8	0.375 to 0.499	1/8
0.056 to 0.065	2500	0	2.3	5	1/2	0.500 to 0.624	1/4
0.066 to 0.070	2500	0	2.2	4.5	5/8	0.625 to 0.749	3/8
0.071 to 0.075	900	110	2.2	4	3/4	0.750 to 0.874	—
0.076 to 0.080	900	100	2.0	3.6	7/8	0.875 to 0.999	1/2
0.081 to 0.085	2000	0	1.8	3.3	1	1.0 to 1.249	3/4
0.086 to 0.090	1800	0	1.6	3	1 1/4	1.250 to 1.499	1
0.091 to 0.095	1800	0	1.6	2.6	1 1/2	1.500 to 1.749	1 1/4
0.096 to 0.109	460	110	1.3	2.3	1 3/4	1.750 to 1.999	1 1/2
0.110 to 0.120	460	110	1.3	2	2	2.000 to 2.999	—

Table 30—Metric High Amps Current Factors and Travel Speeds

Wall mm	High Amps Current Factors			Travel Speed mm/min	Outside Diameter, mm		
	F1	F2	F3		Nominal Tube Size	Actual mm	Nominal Pipe Size (ISO Metric)
0.40 to 0.51	55	0	5.7	254	2.0 to 3.0	1.60 to 3.15	—
0.52 to 0.88	215	-91	3.3	203	3.5 to 6.0	3.16 to 6.34	—
0.89 to 1.17	84	0	2.3	178	6.5 to 9.5	6.35 to 9.51	—
1.18 to 1.40	94	0	2.3	152	10.0 to 12.5	9.52 to 12.6	—
1.41 to 1.65	98	0	2.3	127	13.0 to 15.5	12.7 to 15.7	—
1.66 to 1.78	98	0	2.2	114	16.0 to 18.5	15.8 to 18.9	16
1.79 to 1.91	35	110	2.2	102	19.0 to 22.0	19.0 to 22.1	20
1.92 to 2.00	35	100	2.0	91	22.5 to 25.0	22.2 to 25.3	25
2.01 to 2.16	79	0	1.8	84	25.5 to 31.5	25.4 to 31.6	—
2.17 to 2.29	71	0	1.6	76	32.0 to 38.0	31.7 to 38.0	32
2.30 to 2.41	71	0	1.6	66	38.5 to 44.0	38.1 to 44.3	40
2.42 to 2.77	18	110	1.3	58	44.5 to 50.5	44.4 to 50.7	50
2.78 to 3.00	18	110	1.3	51	60.0 to 76.0	50.8 to 76.1	63

Single Level Mode Operation

In Single Level Mode, single level weld procedure guidelines developed on previous power supplies can be entered using the M200 power supply touch screen. Single Level Mode operation enables the user to enter either single pass or multiple pass weld procedure guidelines. Single Level procedures can be entered manually or by using the Program > Auto Create screen and choosing Levels Only in the Levels/Tacks field, 1-Level in the Procedure Levels Type field, and Active (No-Save) in the Save Procedure field.

Single Level Mode incorporates features of the M200 power supply including the internal mass flow controller, electrode position indicator, Electrode Change button, and the Weld Log.

The touch screen displays the welding process and message information. Messages indicate weld parameter setup errors, power supply status, etc. The status indicator lights on the touch screen show the welding process sequence.

The status indicator lights on the touch screen show the welding process sequence or flash if the power supply detects that a weld parameter is set incorrectly.

Single Level Current-Control Group

The current-control group determines the characteristics of the current output of the power supply during the weld process. The controls (Fig. 63) function as follows:

- **High Amps** sets the maximum current output used during the weld process. This setting affects the depth of penetration of the weld.
- **Low Amps** sets the minimum current output used during the weld process. This is the current level required to maintain the arc and provide enough background heat to maintain the weld puddle.
- **Pulse Rate** sets the number of pulses per second between the High Amps and Low Amps current levels during the weld process.
- **Amps Width** sets the percentage of time the current is at the High Amps level for each High Amps / Low Amps cycle.
- **Delay Current** sets the current during the Delay Time. This current level helps stabilize the initiated arc and develops the weld puddle.



Fig. 63—Single Level Current-Control Group

Single Level Timing-Control Group

The timing-control group determines the weld process timing. The controls (Fig. 64) function as follows:

- **Delay Time** is the time in seconds between the arc start period and rotor movement.

The current specified for the Delay Current is maintained during this time.

The rotor does not move during this time.
- **Prepurge** is the time in seconds when OD shield gas flows through the weld head and around the weld joint before the arc is initiated.

Note: A minimum of 10 seconds prepurge is recommended for all Swagelok weld heads. If weld head extension cables are used, add one second for each foot of extension cable.
- **Weld Time** is the actual welding time in seconds at the average current. During the Weld Time, the output current cycles between High Amps and Low Amps at the Pulse Rate and High Amps Width entered.

During this time, the rotor moves at the speed specified as the Rotor Speed.

Weld Time process forms the main body of the weld.
- **Downslope** is the time in seconds during which the average weld current decreases uniformly until the arc is extinguished.

During this time, the rotor continues to move at the speed specified as the Rotor Speed.

Downslope reduces the likelihood of weld cracking.
- **Postpurge** is the time in seconds the OD shield gas continues to flow through the weld head and around the weld joint after the arc is extinguished. This gas flow prevents oxidation and contamination of the weld bead and electrode while the work piece is cooling.
- **Rotor Speed** is expressed as a percentage of the maximum revolutions per minute (rpm) that the rotor can attain. A rotor speed setting of 99 gives the maximum rpm for the weld head.



Fig. 64—Single Level Timing-Control Group

Single Level Weld Process Buttons

The Weld Process buttons (Fig. 65) control the welding operation and provide some manual control functions for the weld head. The buttons function as follows:

- Electrode Change

Positions the rotor for electrode replacement and prevents to the M200 power supply from welding. See the weld head user's manual for instructions on electrode replacement. After replacing the electrode, press Electrode Change again. The rotor will move the electrode back to the true home position.
- Jog

Press to move rotor *clockwise*. Press again to stop. The light in the corner of the button will blink while the rotor is moving. The rotor will move at the speed defined as the Rotor Speed.
- Jog Back

Press to move rotor *counterclockwise*. Press again to stop. The light in the corner of the button will blink while the rotor is moving. The rotor will move at the speed defined as the Rotor Speed.
- Shield Gas

Activates the mass flow controller and starts the flow of OD shield gas to the weld head until you press the button again. The button overrides prepurge and postpurge timers and allows OD shield gas to flow continuously through the weld head. (Fig. 66)

To set the shield gas, use the *Single Level Weld Procedure Guidelines Worksheets* starting on page 91 and select the OD shield gas visual gauge on the touch screen. Use the keypad in the popup box to set Shield Flow and Purge Tolerance.
- Start

Starts the weld process.
- Home

Press to return the rotor to its true home position. The rotor will move at maximum speed when traveling to the home position, regardless of the programmed rotor speed.
- Print

Prints the last completed Weld Log record.
- Stop

Aborts the weld and halts the rotor if pressed during the weld process. Stop also turns off the OD shield gas flow.



Fig. 65—Single Level Weld Process Buttons

Note: Electrode Change disables most other M200 power supply buttons.

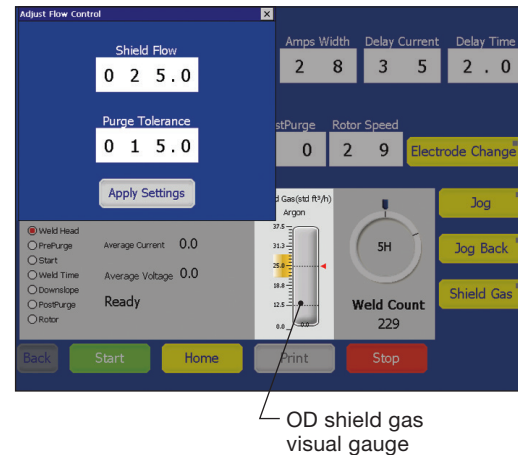

Fig. 66—Single Level Shield Gas Flow Adjustment Popup Box

Single Level Status Indicator Lights

The status indicator lights (Fig. 67) monitor certain elements of M200 power supply operation.

The conditions monitored by some of the indicators are independent of the welding process. Most of the indicators light during the welding process to show the control sequence executed by the M200 power supply. The control sequence is affected by the values entered into the timing-control group.

- **Weld Head** indicates the weld head is connected.
- **PrePurge** indicates the prepurge cycle is in progress.
- **Start** indicates the power supply is in the arc start portion of the weld cycle.
- **Weld Time** indicates the weld process is in progress.
- **Downslope** indicates the downslope cycle is in progress.
- **PostPurge** indicates the postpurge cycle is in progress. OD shield gas continues to flow to the weld head, and the rotor moves to the home position.
- **Rotor** indicates the rotor is in motion.

The display (Fig. 67) monitors system operation during welding and provides message information. The display functions are:

- **Average Current** indicates the average arc current measured during the weld process.
- **Average Voltage** indicates the average arc voltage measured during the weld process.
- **Shield Gas** indicates the gas flow to the weld head.

Single Level Weld Status Conditions

See **Troubleshooting**, page 103, for a list of disable, operational, and weld error conditions.

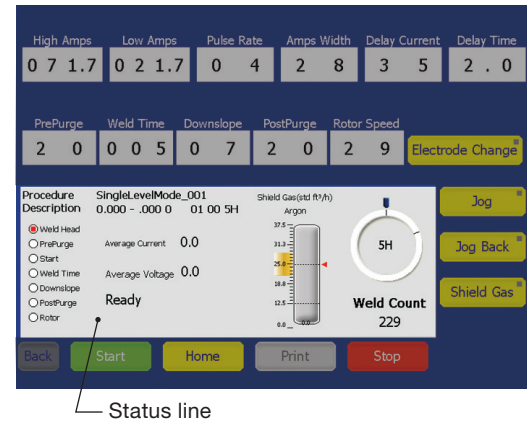

Fig. 67—Single Level Status Indicator Lights and Display

Single Level Weld Procedure Guidelines

These *Single Level Weld Procedure Guidelines* show suggested weld parameter settings based on:

- Swagelok weld head used
- weld joint type
- material type
- outside diameter and wall thickness of the weld joint.

These guidelines are for reference only; modifications may be necessary to achieve the desired results.

Table Note

- The **Average Amps** column lists a calculated value based on certain weld parameters. This value should approximate the value shown on the **Average Current** display during the weld process. Because it is a calculated value, some variation may be seen based on the welding conditions.

Note: The M200 power supply Auto Create feature can be used to generate a one-level, multipass weld procedure.

Any procedure generated manually using the Single Level Weld Procedure Guidelines or generated automatically by the M200 power supply is only a guideline. The final weld quality depends on the operator's welding experience and on the proper use of welding techniques. Parameter adjustments will need to be made and weld quality verified in accordance with the user's quality standards.

Table 31—Series 4MH Weld Head Single Level Weld Procedure Guidelines, Fractional Dimensions

Joint Type	Material	Number of Passes	Diameter, in.	Wall, in.	Arc Gap, in.	Arc Gauge, in.	Travel Speed in./min	High Amps, A	Low Amps, A	Pulse Rate pulses per second	High Amps Width, %	Rotor Delay Current, A	Rotor Delay Time, s	Prepurge, s	Weld Time, s	Downslope, s	Postpurge, s	Rotor Speed, %	Average Amps ^A	Shield Flow std ft ³ /h	ID Flow std ft ³ /h	
TB-TB	316L	Multiple	0.062	0.020	0.020	0.364	4.7	22.0	6.0	10	25	20	0.3	10	5	3	30	99	10.0	8 to 10		
			0.125	0.028	0.030	0.405	6.8	30.8	8.0	10	10	25	20	0.3	10	7	4	30	71	13.7	8 to 10	1 to 5
			0.250	0.035	0.035	0.473	7.2	38.5	10.0	10	10	25	20	0.3	10	13	7	30	38	17.1	8 to 10	1 to 5
JTB-JTB	6LV	Single	0.250	0.035	0.030	0.468	5.1	38.5	10.0	10	24	35	0.8	10	12	4	30	27	16.8	8 to 10	1 to 5	
			0.250	1 mm	0.030	0.468	7.0	43.5	11.0	10	10	26	20	0.3	10	13	7	30	37	19.5	8 to 10	1 to 5
			0.250	1 mm	0.030	0.468	7.0	43.5	11.0	10	10	28	35	0.8	10	9	3	30	37	20.7	8 to 10	1 to 5

Table 32—Series 4MH Weld Head Single Level Weld Procedure Guidelines, Metric Dimensions

Joint Type	Material	Number of Passes	Diameter, mm	Wall, mm	Arc Gap, mm	Arc Gauge, mm	Travel Speed mm/s	High Amps, A	Low Amps, A	Pulse Rate pulses per second	High Amps Width, %	Rotor Delay Current, A	Rotor Delay Time, s	Prepurge, s	Weld Time, s	Downslope, s	Postpurge, s	Rotor Speed, %	Average Amps ^A	Shield Flow std L/min	ID Flow std L/min	
TB-TB	316L	Multiple	3	0.8	0.64	10.08	3.4	31.0	7.8	12	32	20	0.3	10	6	3	30	90	15.2	3.8 to 4.7	1 to 2.4	
			6	1.0	0.76	11.70	2.1	43.3	13.0	10	10	25	20	0.3	10	18	8	30	28	20.6	3.8 to 4.7	1 to 2.4
			6	1.0	0.76	11.0	2.1	43.3	13.0	10	10	23	35	0.3	10	12	4	30	28	20.0	3.8 to 4.7	1 to 2.4

Notes: It is suggested that a continuous OD shield gas flow be used to extend the life of the micro weld head.
 On 1/4 in, 3 mm, and 6 mm tubing, a restrictor with pressure gauge was used. Purge gas pressure was set to 2 to 4 inches of water for 1/4 in.
 and 6 mm; 6 to 8 inches of water for 3 mm.

Table 33—Series 8MH and 8HPH Weld Head Single Level Weld Procedure Guidelines, Fractional Dimensions

Joint Type	Material	Number of Passes	Diameter, in.	Wall, in.	Arc Gap, in.	Arc Gauge, in.	Travel Speed in./min	High Amps, A	Low Amps, A	Pulse Rate pulses per second	High Amps Width, %	Rotor Delay Current, A	Rotor Delay Time, s	Prepurge, s	Weld Time, s	Downslope, s	Postpurge, s	Rotor Speed, %	Average Amps A	Shield Flow std ft ³ /h	ID Flow std ft ³ /h		
TB-TB	316L	Multiple	0.250	0.035	0.035	0.566	6.9	38.5	10.0	10	25	20	0.3	10	14	7	30	36	17.1	15	4 to 7	4 to 7	
			0.375	0.035	0.035	0.629	7.1	38.5	10.0	10	25	20	0.3	10	20	10	30	30	25	17.1	15	4 to 7	4 to 7
		Single	0.250	0.035	0.035	0.566	5.1	38.5	10.0	5	33	35	0.8	10	12	4	30	30	27	19.4	15	4 to 7	4 to 7
			0.375	0.035	0.035	0.629	5.1	38.5	10.0	5	30	35	0.8	10	19	4	30	30	18	18.6	15	4 to 7	4 to 7
ATW-TB	316L	Multiple	0.500	0.049	0.035	0.691	5.0	58.8	18.0	4	38	50	0.8	10	23	5	30	30	13	32.3	15 to 20	4 to 7	4 to 7
			0.250	0.035	0.035	0.585	6.1	48.0	12.0	100	24	21	0.3	10	16	8	30	32	20.6	15 to 20	4 to 7	4 to 7	
		Single	0.375	0.035	0.035	0.678	6.3	48.0	12.0	8	32	21	0.3	10	24	12	30	30	22	23.5	15 to 20	4 to 7	4 to 7
			0.250	0.035	0.035	0.585	4.4	48.0	12.0	6	28	35	0.8	10	14	4	30	30	23	22.1	15 to 20	4 to 7	4 to 7
JTB-JTB	316L	Multiple	0.375	0.035	0.035	0.648	4.6	48.0	12.0	8	34	35	0.8	10	20	6	30	30	16	24.2	15 to 20	4 to 7	4 to 7
			0.250	1 mm	0.030	0.561	6.9	43.5	11.0	10	34	34	0.3	10	14	7	30	36	22.1	12	4 to 7	4 to 7	
		Single	0.375	1 mm	0.035	0.629	6.3	43.5	11.0	8	40	22	0.3	10	23	11	30	30	22	24.0	12	4 to 7	4 to 7
			0.250	1 mm	0.030	0.561	6.9	43.5	11.0	10	34	35	0.8	10	10	3	30	30	36	22.7	12	4 to 7	4 to 7
			0.375	1 mm	0.035	0.629	6.3	43.5	11.0	8	39	0.8	10	16	4	30	30	22	24.5	12	4 to 7	4 to 7	

Notes: It is suggested that a continuous OD shield gas flow be used to extend the life of the micro weld head.

The maximum suggested weld rate on 1/2 × 0.049 in. components is 12 welds per hour. This rate can be increased to 15 welds per hour on smaller-diameter components.

Table 34—Series 8MH and 8HPH Weld Head Single Level Weld Procedure Guidelines, Metric Dimensions

Joint Type	Material	Number of Passes	Diameter, mm	Wall, mm	Arc Gap, mm	Arc Gauge, mm	Travel Speed mm/s	High Amps, A	Low Amps, A	Pulse Rate pulses per second	High Amps Width, %	Rotor Delay Current, A	Rotor Delay Time, s	Prepurge, s	Weld Time, s	Downslope, s	Postpurge, s	Rotor Speed, %	Average Amps A	Shield Flow std L/min	ID Flow std L/min	
TB-TB	316L	Multiple	6	1.0	0.76	14.08	2.1	43.3	14.0	8	26	20	0.3	10	18	8	30	28	21.6	7.1	1.9 to 3.3	
			8	1.0	0.76	15.08	2.1	43.3	14.0	8	8	28	20	0.3	10	23	11	30	21	22.2	7.1	1.9 to 3.3
			10	1.0	0.89	16.21	2.2	43.3	13.0	8	8	38	20	0.3	10	30	15	30	17	24.5	7.1	1.9 to 3.3
ATW-TB	316L	Single	6	1.0	0.76	14.08	2.1	43.3	13.0	8	29	35	0.8	10	12	4	30	28	21.8	7.1	1.9 to 3.3	
			8	1.0	0.76	15.08	2.1	43.3	14.0	8	8	30	35	0.8	10	14	4	30	21	22.8	7.1	1.9 to 3.3
			10	1.0	0.89	16.21	2.2	43.3	14.0	8	8	40	35	0.8	10	19	5	30	17	25.7	7.1	1.9 to 3.3
			12	1.0	0.89	17.21	2.1	43.3	16.0	8	8	42	35	0.8	10	22	6	30	14	26.9	7.1 to 9.4	1.9 to 3.3
			6	1.0	0.76	14.58	2.6	54.4	16.2	10	20	32	20	0.5	10	15	7	30	34	23.8	7.1	1.9 to 3.3
			8	1.0	0.76	15.58	2.6	54.4	16.2	8	21	32	21	0.5	10	20	9	30	26	24.2	7.1	1.9 to 3.3
316L	316L	Single	10	1.0	0.89	16.71	1.9	54.4	16.2	8	17	32	0.5	10	33	16	30	30	15	22.7	7.1	1.9 to 3.3
			6	1.0	0.76	14.58	2.6	54.4	16.2	10	24	35	0.8	10	10	3	30	34	25.4	7.1	1.9 to 3.3	
			8	1.0	0.76	15.58	2.6	54.4	16.2	8	24	35	0.8	10	13	4	30	26	25.4	7.1	1.9 to 3.3	
			10	1.0	0.89	16.71	1.9	54.4	16.2	8	24	35	0.8	10	18	6	30	15	25.4	7.1	1.9 to 3.3	

Notes: It is suggested that a continuous OD shield gas flow be used to extend the life of the micro weld head.
 The maximum suggested weld rate on 12 × 1.0 mm components is 12 welds per hour. This rate can be increased to 15 welds per hour on smaller-diameter components.

Table 35—Series 5H Weld Head Single Level Weld Procedure Guidelines, Fractional Dimensions

Joint Type	Material	Number of Passes	Diameter, in.	Wall, in.	Arc Gap, in.	Arc Gauge, in.	Travel Speed in./min	High Amps, A	Low Amps, A	Pulse Rate pulses per second	High Amps Width, %	Rotor Delay Current, A	Rotor Delay Time, s	Prepurge, s	Weld Time, s	Downslope, s	Postpurge, s	Rotor Speed, %	Average Amps A	Shield Flow std ft ³ /h	ID Flow std ft ³ /h		
TB-TB	316L	Multiple	0.125	0.028	0.030	0.715	4.7	21.5	5.6	25	17	20	0.3	10	10	5	30	99	8.6	12	1 to 4	1 to 4	
			0.250	0.035	0.030	0.777	7.0	38.5	10.0	10	10	22	20	0.3	10	13	7	30	77	17.0	12	4 to 7	4 to 7
			0.375	0.035	0.035	0.845	7.0	38.5	10.0	10	10	31	40	0.3	10	20	10	30	50	19.0	12	5 to 10	5 to 10
			0.500	0.035	0.035	0.907	7.0	42.5	10.0	10	10	28	20	0.3	10	27	14	30	37	19.1	12	5 to 10	5 to 10
			0.500	0.049	0.035	0.907	7.0	58.8	18.0	10	10	35	32	0.5	10	27	14	30	37	32.0	12	5 to 10	5 to 10

Table 36—Series 10H Weld Head Single Level Weld Procedure Guidelines, Fractional Dimensions

Joint Type	Material	Number of Passes	Diameter, in.	Wall, in.	Arc Gap, in.	Arc Gauge, in.	Travel Speed in./min	High Amps, A	Low Amps, A	Pulse Rate pulses per second	High Amps Width, %	Rotor Delay Current, A	Rotor Delay Time, s	Prepurge, s	Weld Time, s	Downslope, s	Postpurge, s	Rotor Speed, %	Average Amps A	Shield Flow std ft ³ /h	ID Flow std ft ³ /h			
TB-TB	316L	Multiple	0.250	0.035	0.035	1.157	7.0	38.5	10.0	10	25	20	1.3	20	13	7	30	77	17.0	12 to 15	12 to 15	4 to 7	4 to 7	
			0.375	0.035	0.035	1.219	7.0	40.5	10.0	10	10	29	20	0.3	20	20	10	30	50	19.0	12 to 15	12 to 15	5 to 10	5 to 10
			0.500	0.035	0.035	1.282	7.0	42.0	10.0	10	10	34	20	0.3	20	27	14	30	37	20.9	12 to 15	12 to 15	5 to 10	5 to 10
			0.500	0.049	0.035	1.281	7.0	58.8	18.0	10	10	35	32	0.5	20	27	14	30	37	32.0	12 to 15	12 to 15	5 to 10	5 to 10
			0.750	0.049	0.045	1.417	5.5	58.8	18.0	6	6	35	32	0.5	20	26	13	30	19	32.0	12 to 15	12 to 15	5 to 10	5 to 10
	316L	Single	1.000	0.065	0.045	1.542	5.0	78.0	23.0	6	35	41	0.5	20	38	19	30	13	41.0	15	7 to 15	7 to 15		
			1.000	0.083	0.045	1.542	5.0	99.6	30.0	6	6	39	54	0.5	20	38	19	30	13	57.1	15 to 17	15 to 17	7 to 15	7 to 15

Table 37—Series 20H Weld Head Single Level Weld Procedure Guidelines, Fractional Dimensions

Joint Type	Material	Number of Passes	Diameter, in.	Wall, in.	Arc Gap, in.	Arc Gauge, in.	Travel Speed in./min	High Amps, A	Low Amps, A	Pulse Rate pulses per second	High Amps Width, %	Rotor Delay Current, A	Rotor Delay Time, s	Prepurge, s	Weld Time, s	Downslope, s	Postpurge, s	Rotor Speed, %	Average Amps A	Shield Flow std ft ³ /h	ID Flow std ft ³ /h	
TB-TB	316L	Multiple	0.500	0.035	0.040	1.849	7.0	38.5	10.0	10	27	20	0.3	30	28	14	30	74	18.0	12 to 15	5 to 10	
			0.500	0.049	0.040	1.849	6.0	58.8	18.0	10	10	25	40	0.5	30	31	16	30	65	28.0	12 to 15	5 to 10
		Single	0.750	0.049	0.045	1.980	5.0	58.8	18.0	6	43	32	0.5	30	28	14	30	36	35.0	12 to 15	5 to 10	
			1.000	0.065	0.045	2.105	5.0	78.0	23.0	6	6	35	42	0.5	30	38	19	30	26	42.0	12 to 15	5 to 10
			1.000	0.083	0.045	2.105	4.0	99.6	30.0	6	6	35	54	0.5	30	47	24	30	21	54.0	15	7 to 15
			1.250	0.065	0.045	2.230	5.0	78.0	23.0	4	4	35	42	0.5	30	47	24	30	21	42.0	15	7 to 15
			1.250	0.083	0.045	2.230	4.0	99.6	30.0	4	4	35	54	0.5	30	59	30	30	17	54.0	15	7 to 15
			1.500	0.065	0.045	2.355	5.0	78.0	23.0	4	4	43	42	0.5	30	57	29	30	18	47.0	15	7 to 15
			1.500	0.083	0.045	2.355	4.0	99.6	30.0	4	4	50	54	0.5	30	71	36	30	14	64.8	15	7 to 15
			1.750	0.065	0.045	2.480	4.0	78.0	23.0	4	4	35	42	0.5	30	82	41	30	12	42.0	15	10 to 20
			2.000	0.065	0.045	2.605	5.0	78.0	23.0	4	4	39	42	0.5	30	75	38	30	13	42.0	15	10 to 20
			2.000	0.083	0.045	2.605	4.0	99.6	30.0	4	4	40	54	0.5	30	94	47	30	11	57.8	15 to 17	10 to 20
2.000	0.109	0.045	2.605	4.0	99.9	57.0	4	4	50	78	1.0	30	94	47	30	11	78.5	15 to 20	10 to 20			

Table 38—Series 40H Weld Head Single Level Weld Procedure Guidelines, Fractional Dimensions

Joint Type	Material	Number of Passes	Diameter, in.	Wall, in.	Arc Gap, in.	Arc Gauge, in.	Travel Speed in./min	High Amps, A	Low Amps, A	Pulse Rate pulses per second	High Amps Width, %	Rotor Delay Current, A	Rotor Delay Time, s	Prepurge, s	Weld Time, s	Downslope, s	Postpurge, s	Rotor Speed, %	Average Amps A	Shield Flow std ft ³ /h	ID Flow std ft ³ /h
TB-TB	316L	Single	1.50	0.065	0.060	—	3.82	92.3	28.0	2	33	49.2	2.6	45	76.5	5.0	45	32	49.2	40	90
			1.50	0.083	0.060	—	2.97	97.6	34.9	2	39	59.3	3.4	45	99.5	6.5	45	25	59.4	40	90
			1.75	0.065	0.060	—	3.63	92.3	28.0	2	33	49.2	2.6	45	93.0	6.1	45	26	49.2	40	130
			1.75	0.083	0.060	—	2.80	97.6	34.9	2	39	59.3	3.6	45	121.5	8.0	45	20	59.4	40	130
			2.00	0.065	0.060	—	3.52	92.3	28.0	2	33	49.2	2.6	45	110.0	7.3	45	22	49.2	40	170
			2.00	0.083	0.060	—	2.64	97.6	34.9	2	39	59.3	3.8	45	146.5	9.6	45	17	59.4	40	170
			2.00	0.095	0.060	—	2.32	101.5	39.0	1	43	65.8	5.0	45	169.0	11.1	45	15	65.9	40	170
			2.00	0.109	0.060	—	2.14	99.2	43.1	2	47	69.6	6.1	45	181.5	12.0	45	14	69.5	40	170
			2.50	0.065	0.060	—	3.53	92.3	28.0	2	33	49.2	2.6	45	137.0	9.0	45	18	49.2	40	280
			2.50	0.083	0.060	—	2.67	97.6	34.9	2	39	59.3	3.8	45	182.0	12.0	45	14	59.4	40	280
			2.50	0.095	0.060	—	2.28	101.5	39.0	1	43	65.8	5.0	45	210.0	13.8	45	12	65.9	40	280
			2.50	0.109	0.060	—	2.12	99.2	43.1	2	47	69.6	6.1	45	225.5	14.9	45	11	69.5	40	280
			3.00	0.065	0.060	—	3.49	92.3	28.0	2	33	49.2	2.6	45	164.0	10.8	45	15	49.2	40	400
			3.00	0.083	0.060	—	2.64	97.6	34.9	2	39	59.3	3.8	45	217.5	14.3	45	11	59.4	40	400
			3.00	0.095	0.060	—	2.26	101.5	39.0	1	43	65.8	5.0	45	251.0	16.6	45	10	65.9	40	400
			3.00	0.109	0.060	—	2.17	99.2	43.1	2	47	69.6	6.1	45	269.5	17.8	45	9	69.5	40	400
			3.50	0.065	0.060	—	3.52	92.3	28.0	2	33	49.2	2.6	45	191.0	12.6	45	13	49.2	40	560
			3.50	0.083	0.060	—	2.64	97.6	34.9	2	39	59.3	3.8	45	253.0	16.7	45	10	59.4	40	560
			3.50	0.095	0.060	—	2.31	101.5	39.0	1	43	65.8	5.0	45	292.0	19.3	45	8	65.9	40	560
			3.50	0.109	0.060	—	2.20	99.2	43.1	2	47	69.6	6.1	45	313.0	20.7	45	8	69.5	40	560
4.00	0.065	0.060	—	3.52	92.3	28.0	2	33	49.2	2.6	45	218.0	14.4	45	11	49.2	40	720			
4.00	0.083	0.060	—	2.64	97.6	34.9	2	39	59.3	3.8	45	288.5	19.0	45	8	59.4	40	720			
4.00	0.095	0.060	—	2.26	101.5	39.0	1	43	65.8	5.0	45	333.0	22.0	45	7	65.9	40	720			
4.00	0.109	0.060	—	2.14	99.2	43.1	2	47	69.6	6.1	45	357.0	23.5	45	7	69.5	40	720			

Evaluating Weld Quality

Identifying Proper Welds

Figure 68 illustrates an acceptable weld: continuous full penetration from the outside diameter (OD) to the inside diameter (ID); a crown on the OD; and minimal weld bead convexity on the ID.

To determine whether a weld is proper or improper:

1. Inspect the weld on the *outside* of the tube for:
 - Uniformity.
 - Cracks.
 - Undercuts.
 - Excessive oxide.
2. Inspect the weld on the *inside* of the tube for:
 - Uniformity, cracks, undercuts, and excessive oxidation.
 - Full penetration.
 - Excessive weld-bead width variations.
 - Excessive weld-puddle overlap.

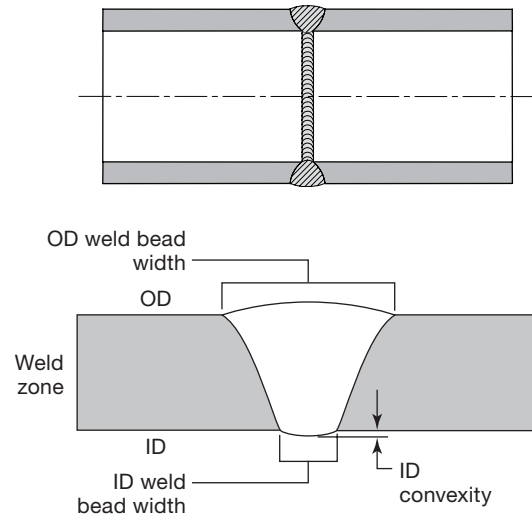

Fig. 68—Acceptable Weld

Identifying Typical Weld Discontinuities

Figure 69 shows typical weld discontinuities.

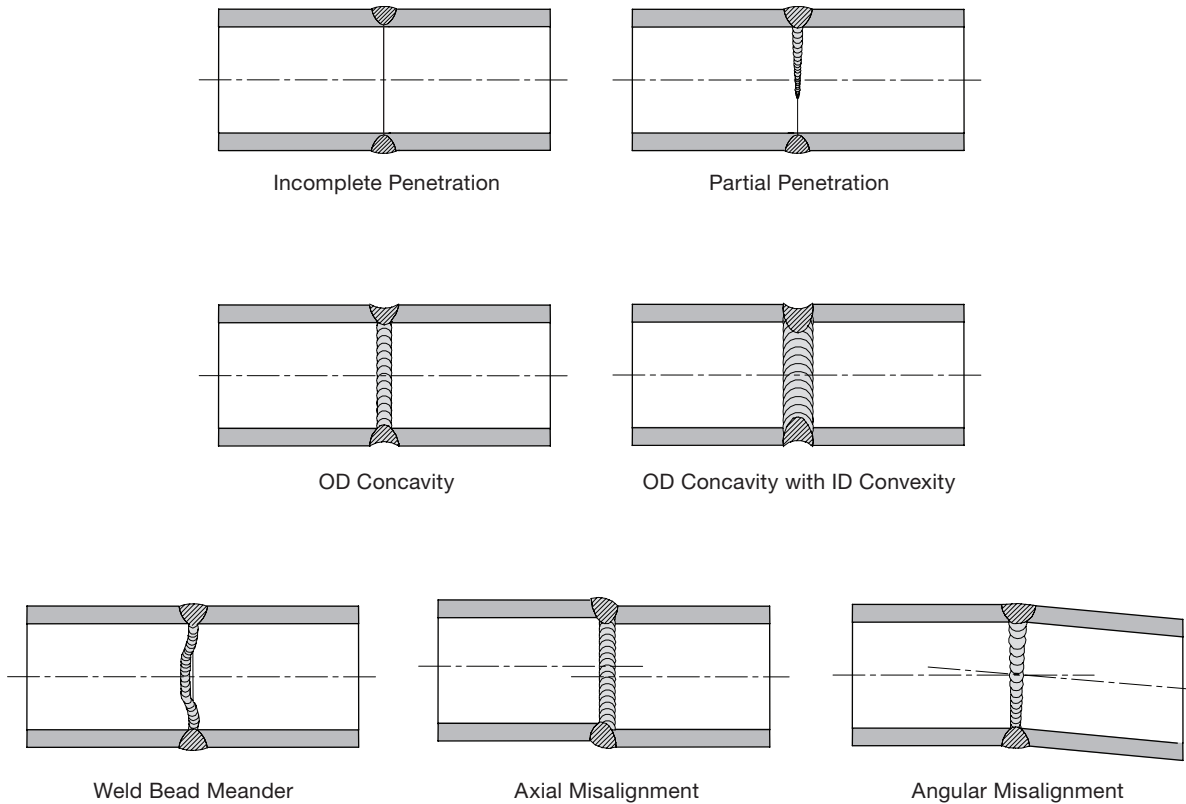

Fig. 69—Typical Weld Discontinuities

Improper Welds

The following weld examples show how changes in weld parameters affect weld shape. The reference weld (Fig. 70 and 71) was made using a 316L stainless steel tube with a 1/2 in. OD and 0.049 in. wall thickness, in accordance with the weld parameter settings shown below:

Parameter	1	2	3	4
High Amps, A	71.7	68.1	64.5	60.9
Low Amps, A	21.7	21.7	21.7	21.7
Weld Time, s	5.0	5.0	5.0	5.0
Ramp Time, s	0.0	0.0	0.0	0.0
Pulse Rate, Hz	4.0	4.0	4.0	4.0
High Amps Width, %	28.0	28.0	28.0	28.0
High Amps Speed, rpm	3.5	3.5	3.5	3.5
Low Amps Speed, rpm	3.5	3.5	3.5	3.5
Average Amps, A	35.7	34.7	33.7	32.7

Below are guidelines on what to look for when troubleshooting a weld that did not penetrate the ID; displayed too much ID convexity and weld bead width; or showed too much or too little weld-puddle overlap. To make adjustments to the parameters, check them against the Auto Create values and see **Advanced Weld Procedure Techniques**, page 66, for more tips on correcting an improper weld.

No ID Penetration

Lack of ID penetration can be caused by several improper weld procedure settings.

All of the examples shown below result from *decreased* arc intensity and—consequently—heat input, resulting in no ID penetration.

High Amps Width Too Short (Fig. 72)

High Amps Width setting changed from 28 to 24 %.

This lowers the Average Amps from 35.7 to 33.7 A.

High Amps Current Too Low (Fig. 73)

High Amps setting changed from 71.7 to 55.4 A.

This lowers the Average Amps from 35.7 to 34.1 A.

Low Amps Current Too Low (Fig. 74)

Low Amps setting changed from 21.7 to 14.8 A.

This lowers the Average Amps from 35.7 to 30.7 A.

Rotor Speed Too High (Fig. 75)

Rotor speed changed from 3.5 to 4 rpm.

This lowers the average heat input per unit of time. Although the Average Amps for the weld is unchanged, Weld Time is decreased by 12.5 % and the heat input is decreased by 12.5 %.

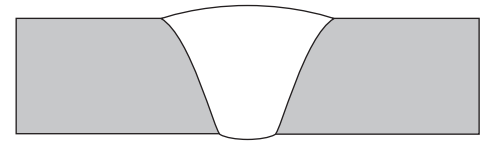

Fig. 70—Reference Weld Cross Section

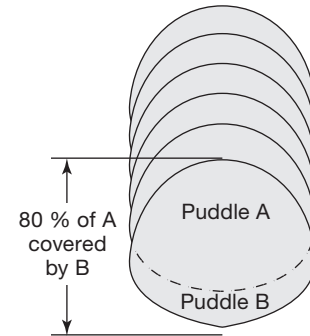

Fig. 71—Reference Weld-Puddle Overlap

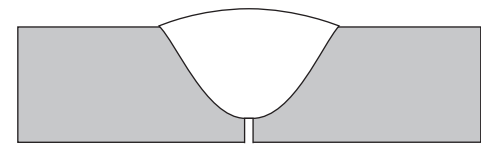

Fig. 72—High Amps Width Too Short

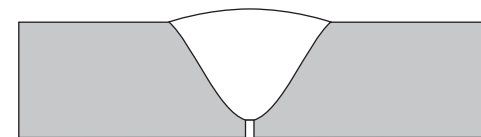

Fig. 73—High Amps Current Too Low

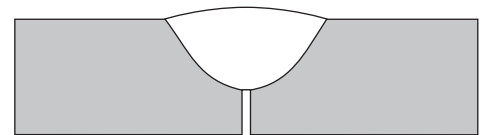

Fig. 74—Low Amps Current Too Low

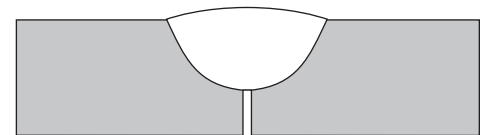

Fig. 75—Rotor Speed Too High

Increased ID Convexity and Weld Bead Width

Increased ID convexity and weld bead width can be caused by several improper weld procedure settings.

All of the examples shown below result from *increased* arc intensity and, consequently, heat input, resulting in increased ID convexity and weld bead width.

High Amps Width Too Long (Fig. 76)

High Amps Width setting changed from 28 to 33 %.

This raises the Average Amps from 35.7 to 38.1 A.

High Amps Current Too High (Fig. 77)

High Amps setting changed from 71.7 to 80.6 A.

This raises the Average Amps from 35.7 to 38.2 A.

Low Amps Current Too High (Fig. 78)

Low Amps setting changed from 21.7 to 25.2 A.

This raises the Average Amps from 35.7 to 38.2 A.

Rotor Speed Too Low (Fig. 79)

Rotor speed changed from 3.5 to 2 rpm.

This increases the average heat input per unit of time. Although the Average Amps for the weld is unchanged, Weld Time is increased by 75 % and the heat input is increased by 75 %.

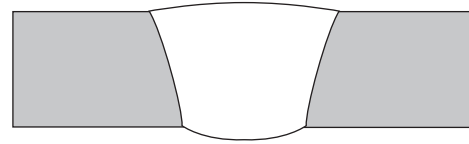

Fig. 76—High Amps Width Too Long

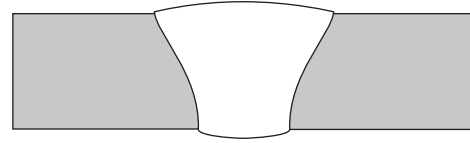

Fig. 77—High Amps Current Too High

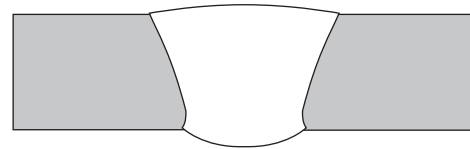

Fig. 78—Low Amps Current Too High

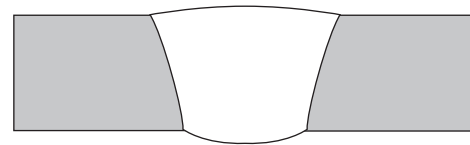

Fig. 79—Rotor Speed Too Low

Weld-Puddle Overlap

The pulse rate should be set so that each weld puddle overlaps the previous one by about 80 %, as shown in Fig. 71. Changing the pulse rate can affect weld-puddle overlap and cause inadequate weld penetration or weld distortion.

Not Enough Weld-Puddle Overlap (Fig. 80)

If the weld puddles do not overlap enough, the weld can lose full penetration in some areas. Increasing the pulse rate from 10 to 25 per second will increase weld-puddle overlap and ensure full penetration of the weld joint.

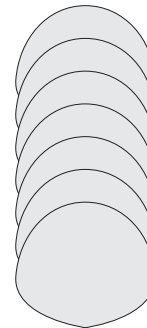

Fig. 80—Not Enough Weld-Puddle Overlap

Too Much Weld-Puddle Overlap (Fig. 81)

If the weld puddles overlap too much, the weld puddle may become distorted around the perimeter. Decreasing the pulse rate from 10 to 5 per second will decrease weld-puddle overlap and provide a more uniform appearance around the edges of the weld.

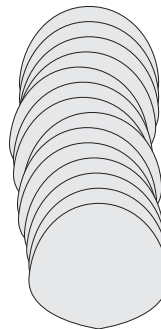

Fig. 81—Too Much Weld-Puddle Overlap

Specifications

M200 Power Supply Output and Duty Cycle

Table 39—M200 Power Supply Output

Average Output Current Range	Maximum Peak Output Current	Maximum Open Circuit Voltage
2 to 200 A	200 A	90 V

Table 40—M200 Power Supply Duty Cycle at 40°C (104°F)

Duty Cycle	Input Circuit	Output Voltage	Average Output Current
100 %	100 V / 20 A	13.2 V	95 A
100 %	115 V / 20 A	15.7 V	100 A
25 %	230 V / 16 A	18.0 V	200 A
60 %	230 V / 16 A	15.6 V	140 A
100 %	230 V / 16 A	14.8 V	120 A

M200 Power Supply with 115 V Input

The rated output of the M200 power supply is available when connected to a 230 V / 20 A branch circuit. When connected to a branch circuit with a lower voltage, lower welding current and duty cycle must be used. An output guide is provided below. The values are approximate and must be adjusted downward if the fuse or circuit breaker trips off. Other loads on the circuit and fuse/circuit breaker characteristics will affect the available output. Do not exceed these welding conditions:

15 A Plug on 15 A Branch	20 A Plug on 20 A Branch
10 % duty cycle 95 A	10 % duty cycle 120 A
15 A Plug on 20 A Branch	
10 % duty cycle 105 A	

M200 Power Supply Cycle Times

The duty cycle rating (expressed as a percentage) refers to the maximum weld time allowed during a given period of time. The balance of the cycle is required for cooling. The industry standard is a 10-minute duty cycle. The weld and idle times for several 10-minute duty cycle ratings are shown in Table 41.

Table 41—M200 Power Supply 10-Minute Cycle Times

Duty Cycle	Maximum Weld Time	Required Idle Time
25 %	2.5 min	7.5 min
60 %	6 min	4 min
100 %	10 min	0 min

Continually exceeding the duty cycle may activate the internal thermal protector that will disable the power supply and display a disable condition on the screen.

M200 Power Supply Dimensions

Table 42—M200 Power Supply Dimensions and Weight

Dimensions	Weight
Height: 13.5 in. (34.3 cm)	49.7 lb (22.5 kg)
Width: 22.8 in. (57.9 cm)	
Depth: 15.5 in. (39.4 cm)	

Use of Extension Cords with the M200 Power Supply

Some power loss will occur, depending on the length of the extension cord. See Table 43 to determine the minimum wire size to use.

Table 43—Extension Cords

Supply Voltage	Wire Gauge 0 to 50 ft (0 to 15 m)	Wire Gauge 50 to 100 ft (15 to 30 m)
115 V (ac)	#12 AWG (2.5 mm)	#10 AWG (4.0 mm)
230 V (ac)	#12 AWG (2.5 mm)	#10 AWG (4.0 mm)



WARNING

Do not use extension cords that are in poor physical condition or have insufficient current capacity. Electrical shock can result.

NOTICE

The voltage drop in an extension cord over 100 ft (30 m) may affect the output performance of the M200 power supply.

Troubleshooting

This section contains troubleshooting guidelines for the M200 power supply and software, including:

- weld status conditions
- weld system hardware and weld process problems
- power supply repair.

Weld Status Conditions

Disable

Disable conditions must be corrected before a weld can be executed. A **D:** on the status line indicates a disable condition (Fig. 82).

Table 44—Disable Conditions

Disable Message	Description	Remedy
D: Electrode change mode	Electrode Change is still active.	Press Electrode Change again.
D: Fault LCD backlight	The M200 power supply touch screen backlight is not working properly.	Call for service.
D: Fixture not found	A fixture is not attached to the work piece.	Attach the correct fixture.
D: High rotor speed	The weld head cannot provide the speed programmed in the active weld procedure.	Adjust the rotor speed or change the weld head.
D: Invalid procedure	The weld procedure selected is not executable.	A parameter field must be filled in within tolerance using the Weld screen.
D: MD failed init	The motor driver inside the M200 power supply (controlling weld head movement) is not functioning properly.	Call for service.
D: MFC no flow	No OD shield gas flow is present. The weld is stopped immediately to prevent weld head damage.	Check gas connection and purge connector attachment to weld head for an obstruction in the purge path. If OD shield flow control is disabled on the Setup > Flow Control tab, this error will not display.
D: MFC oscillation	Flow has become unstable and the weld will be stopped.	Reduce input pressure until flow has stabilized.



Fig. 82—Disable Condition Message

Table 44—Disable Conditions

Disable Message	Description	Remedy
D: AC input error	An AC input error was detected. The weld attempted requires more voltage or current from the wall outlet.	<p>Welding can continue once the M200 power supply resets. Using 230 V (ac) would prevent this error.</p> <p>The M200 power supply requires 90 V minimum for 115 V and 180 V minimum for 230 V.</p> <p>Reduce the extension cord or weld head cable length. Or increase the gage of the extension cord.</p>
D: Power source high temp	The M200 power supply is exceeding the temperature rating.	The M200 power supply will reset automatically when it has cooled to within limits.
D: Rotor jam	The rotor stopped turning during the weld procedure.	Remove obstruction from weld head and press Next Home on the Main screen.
D: Update user fields	A required field has not been completed.	Complete all required fields on User Fields 1 and User Fields 2 tabs on the Weld screen.
D: USB flash drive required	When Setup > Weld Log "Save to USB flash drive" is active, a USB flash drive must be attached.	Attach a USB flash drive.
D: Weld engine DLL not found	The M200 power supply cannot find the operating system, or the software is not loading, or has not been updated properly.	Call for service.
D: Weld head not found	A weld head is not attached to the power supply.	Attach the correct weld head.

Operational

Operational conditions should be noted, but the weld may proceed with discretion. A **W:** on the status line indicates an operational condition (Fig. 83). Operational conditions are recorded in the Weld Log if the condition is not corrected before starting the weld.

Table 45—Operational Conditions

Operational Message	Description	Remedy
W: AC power failure	There was an interruption in the alternating current to the M200 power supply.	See M200 Power Supply Specifications , page 101.
W: DC power failure	There was an interruption to the internal power source of the M200 power supply.	Call for service.
W: Exceeding weld head current	The maximum current in the loaded weld procedure exceeds the limits of the attached weld head.	Lower the average current or extend the weld time in the weld procedure.
W: MD busy bit	The motor driver inside the M200 power supply (controlling weld head movement) did not accept a command from the weld procedure.	The M200 power supply will reset itself automatically.
W: MD command error	The motor driver inside the M200 power supply (controlling weld head movement) did not accept a command from the weld procedure.	Powering off the M200 power supply, then powering on again should correct this condition.
W: MFC warming up	The MFC has not completed warmup.	Wait 5 minutes after the M200 power supply is powered on to ensure accurate gas flow control.
W: Printer head up	The printer head is up for loading.	Close printer cutting head.
W: Printer high temp	The printer has overheated. It must cool before it can print.	The printer will function properly when it has cooled.
W: Printer out of paper	The printer is out of paper.	Load a new roll of paper.

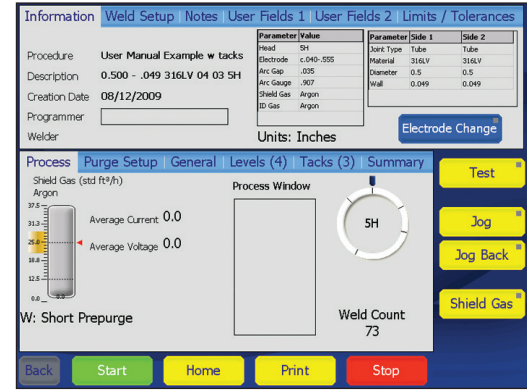

Fig. 83—Operational Condition Message

Table 45—Operational Conditions

Operational Message	Description	Remedy
W: Short prepurge	The prepurge time is set for less than 5 seconds. If the Shield Gas button on the Weld screen is active, this operational condition will not be displayed.	Set prepurge time for longer than 5 seconds, or press the Shield Gas button on the Weld screen.
W: Unsupported gas	The OD shield or ID purge gas in the loaded weld procedure is not supported by the M200 power supply.	Change the gas to one supported by the Auto Create menu.
W: Weld head not home	The weld head is not in the true home position.	Press Home on the touch screen.
W: Wrong weld head	The active weld procedure specifies a different weld head.	Attach the correct weld head.

Weld Errors

Weld errors indicate problems that occurred during the weld process. “Weld completed” or “Weld not completed” will be displayed on the status line and on the summary screen (Fig. 84).

A description of the error will be displayed in a dialog box, and the alarm will sound if the alarm function has been turned on (see Table 15, page 47). The condition must be acknowledged by pressing OK in the dialog box before the next weld can be made. Weld errors are recorded in the Weld Log and will display in red.

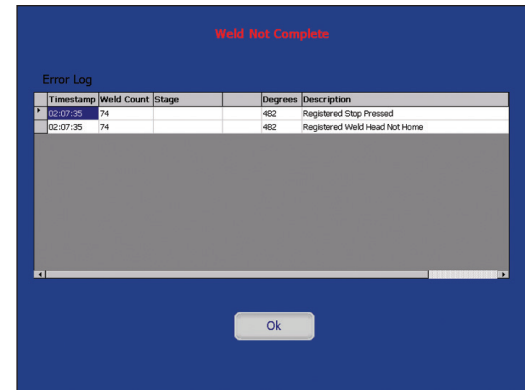

Fig. 84—Weld Error Message

Table 46—Weld Error Conditions

Weld Error Message	Description	Remedy
AC power failure	There was an interruption in the alternating current to the M200 power supply.	See M200 Power Supply Specifications , page 101.
Arc failed	The arc failed during the weld.	Check the arc gap setting.
Current tolerance	The weld did not perform within the specified current tolerance. Tolerance is set on the Weld screen Limits / Tolerances tab.	Review current limits.
DC power failure	There was an interruption to the internal power source of the M200 power supply.	Call for service.
Electrode touch	The electrode touched the weld puddle or work piece during the weld.	See Table 51 for remedies before performing the next weld.
MD busy bit	The motor driver inside the M200 power supply (controlling weld head movement) did not accept a command from the weld procedure.	The M200 power supply will reset itself automatically.
MD command error	The motor driver inside the M200 power supply (controlling weld head movement) did not accept a command from the weld procedure.	Powering off the M200 power supply, then powering on again should correct this condition.
MFC no flow	No OD shield gas flow is present. The weld is stopped immediately to prevent weld head damage.	Check gas connection and purge connector attachment to weld head for an obstruction in the purge path. If OD shield flow control is disabled on the Setup > Flow Control tab, this error will not display.
MFC oscillation	Flow has become unstable and the weld will be stopped.	Reduce input pressure until flow has stabilized.

Table 46—Weld Error Conditions

Weld Error Message	Description	Remedy
Misfire	The arc was not established.	Check the arc gap setting, electrode, and fixture.
Power source AC overcurrent	The input current (ac) is above the M200 power supply rating using 115 V (ac) input, and the weld will be stopped.	Welding can continue once the M200 power supply resets. Using 230 V (ac) would prevent this error.
Power source AC voltage	The input alternating current voltage is not allowable.	The M200 power supply requires 90 V minimum for 115 V and 180 V minimum for 230 V.
Power source high temp	The M200 power supply has overheated. If this occurs during a weld, the M200 power supply will stop the weld immediately.	This condition resets automatically when the M200 power supply has cooled. If welding heavy-wall tubing, keeping the fan on constantly could prevent this error.
Power source overcurrent	The average output current (dc) is above the M200 power supply rating using 115 V (ac) input, and the weld will be stopped.	Welding can continue once the M200 power supply resets. Using 230 V (ac) would prevent this error.
Rotor jam	The rotor stopped turning during the weld procedure.	Remove obstruction from weld head and press Next Home on the Main screen.
Speed tolerance	The weld did not perform within the specified speed tolerance. Tolerance is set on the Weld screen Limits / Tolerances tab.	Attach the correct weld head for the loaded weld procedure.
Stop pressed	The user pressed Stop to abort the weld.	Inspect work pieces and setup. Start new weld.
Tacks not complete	One or more tacks were not successful	Inspect tacks and adjust weld procedure.
Weld head not home	The weld head is not in the true home position.	Press Home on the touch screen.

Weld System Hardware and Weld Process Problems

Repair / Replacement Instructions

Certain remedies require a component, such as a weld head, to be disassembled, cleaned, or replaced. For user maintenance weld procedures, see the **Maintenance** section of the weld head user's manual (www.swagelok.com). Contact your authorized Swagelok representative with any questions.

Table 47—Power Supply

Symptom	Cause	Remedy
OD shield gas visual gauge is not reading any flow.	From Supply and To Weld Head connections on the side of the M200 power supply are attached in reverse.	Correct the connections on the M200 power supply.
OD shield gas visual gauge is not reading desired flow rate.	Insufficient input pressure.	Increase input pressure.
Power supply fan does not operate during weld process.	Internal component failure.	Call for service.
Touch screen is blank.	The M200 power supply ON/OFF switch is off.	Toggle on the M200 power supply ON/OFF switch.
	The M200 power supply power cord is not plugged in.	Plug the M200 power supply power cord into the wall outlet.
Touch screen is not working properly / cursor does not follow the fingertip.	Water or other contaminant is on the screen.	Let the screen dry, or clean it (with the M200 power supply powered off.)
	Touch screen is no longer calibrated.	Recalibrate the touch screen from Setup > Touchscreen > Calibrate Touchscreen.

NOTICE

Do not exceed an inlet pressure of 100 psig (6.8 bar) or MFC can be damaged.

Table 48—Weld Head

Symptom	Cause	Remedy
Rotor does not return to the true home position.	Weld head connector is not fully engaged.	Check that the weld head connector is seated on the M200 power supply and the collar is tight.
	Bad weld head connector cable.	Replace weld head connector cable.
	Rotor is not at the true home position when the power supply is toggled on.	Press Next Home to move the rotor to the home position.
	Dirty home sensor.	Disassemble the weld head and check the home sensor for dirt. See the motor and power block assembly drawing in the weld head user's manual. Use compressed air to blow off debris.
	Rotor gear ring is misaligned with secondary gears.	Realign the rotor with the weld head opening.
	Weld head connector has broken or damaged pins / wires.	Call for service.
	Home sensor is damaged or misaligned.	Call for service.
Rotor squeaks when turning.	Dirty or worn weld head body halves.	Disassemble the weld head and clean or replace components.
	Gear bearings worn or dirty.	Clean or replace bearing assemblies as needed.
	Dirty ball bearings in rotor.	Disassemble rotor and clean or replace ball bearings as needed.
Rotor does not move or makes a clicking noise when turning.	Debris on gears.	Check for weld spatter or debris on gears.
	Loose drive clip in the micro weld head.	Check and replace drive clip if needed.
	Brush spring is installed incorrectly in micro weld head.	Install the brush spring in the correct orientation.
	Bent motor shaft.	Call for service.

*Note: See the **Maintenance** section of the weld head user's manual for more information about correcting problems with weld heads.*

Table 48—Weld Head

Symptom	Cause	Remedy
Erratic rotor rotation / speed control.	Weld spatter on gears.	Inspect the rotor primary, secondary, and drive gears for damage. Replace damaged gears.
	Arcing damage on rotor gear teeth.	Inspect rotor and replace if damaged.
	Dirty weld head, debris on encoder sensor or encoder wheel.	Disassemble the weld head and clean thoroughly.
	Encoder wheel slips on motor shaft.	Call for service.
	Weld head connector has broken wire.	Call for service.
Arc damage on rotor gear.	Arcing from rotor.	Clean gear, replace if necessary.
Damage to weld head body halves.	Arcing	Disassemble the weld head. Clean or replace parts as needed.
	Excessive heat from welding.	Check weld procedure guideline. Use a larger weld head, allow a cooling period between welds, or allow continuous OD shield gas flow when welding.
	Weld head was dropped	Check for damage and replace parts as necessary. Check rotor for smooth operation. Call for service if damage is severe.

*Note: See the **Maintenance** section of the weld head user's manual for more information about correcting problems with weld heads.*

Table 49—Electrode

Symptom	Cause	Remedy
Material found on the electrode tip.	Electrode touched the weld puddle.	Replace electrode and check arc gap setting. Check work pieces for out of roundness.
	Weld puddle protrusion.	Check ID purge gas flow rate for excessive back pressure.
	Weld head is not properly attached to the fixture block.	Reattach the weld head to fixture block. Engage the weld head locking lever.
Oxidation film on the electrode.	Insufficient OD shield gas.	Increase OD shield gas flow.
	Insufficient post purge time.	Increase post purge time.
	Partially blocked or cut OD shield gas line.	Check for leaks and / or blockages. Replace gas lines if needed.
	O-ring missing between the weld head and motor module (micro weld head only.)	Check and install O-ring if necessary.
	OD shield gas line disconnected inside weld head.	Disassemble weld head and reconnect the line.
Bent or broken electrode.	Electrode was not secured in the rotor.	Replace the electrode. Tighten electrode clamping screws.
	Weld head not correctly attached to the fixture block.	Replace the electrode. Reattach the weld head to the fixture block. Engage the weld head locking lever.
	Incorrect arc gap setting.	Check the length of the electrode and replace it. Reset arc gap.
Melted electrode.	No OD shield gas.	Check for OD shield gas flow and set the proper flow rate. Enable Shield Flow Control on Main > Setup/Flow Control tab.

Table 50—Fixture Block

Symptom	Cause	Remedy
When closing the fixture block side plate, the latch does not lock.	The latch is not inserted into the fixture block side plate completely.	Reinsert the latch into the side plate until it rests against the latch pin.
	Bent latch.	Replace latch.
	Oversized tubing.	Replace fitting / tubing with the correct size.
	Wrong size collets.	Replace with the correct size collet.
	Hinge worn out.	Replace the hinge and dowel pins.
	Worn out latch cam.	Replace the latch cam.
The latch does not fit into the bottom part of the fixture block side plate.	A burr is in the slot or on the latch.	Use a fine file to remove burrs.
	The latch is bent or damaged.	Remove the hinge and replace all damaged parts.
The fixture block does not fit onto the weld head.	The arc gap is incorrect.	Reset the arc gap with the arc gap gauge.
	The locking ring tab is broken or damaged.	Replace the locking ring tab.
	The weld head is incorrectly assembled.	Reassemble using the instructions found in the Maintenance section of the weld head user's manual.
	Arc damage on fixture.	Clean fixture. Remove and replace any damaged parts.

Table 51—Welding Process

Symptom	Cause	Remedy
Arc fails to start.	Incorrect arc gap setting.	Reset the arc gap with the arc gap gauge.
	Excessive purge gas flow.	Reduce flow to the value shown on the weld procedure guideline.
	Insufficient OD shield gas flow or contaminated OD shield gas.	Check the gas source for low pressure and leaks. Change to a different gas source or change oxygen removal filter.
	Electrode in poor condition.	Replace electrode.
	Damaged electrical connections in the weld head.	Call for service.
	Poor contact between locking ring tab and ground extension.	Inspect and clean all contact surfaces.
	Poor contact between rotor and brush.	Inspect and clean all contact surfaces.
	Poor contact between tubing, collet, and fixture block.	Inspect and clean all contact surfaces.
Start power set too low.	Set start power to normal.	
Voltage fluctuations during the weld cycle exceeding 2 V.	Weld head not seated properly into the fixture block.	Reattach the weld head to the fixture block. Engage the weld head locking lever.
	Work pieces are out of round.	Replace work pieces if out of standard specifications.
	Insufficient OD shield gas flow or contaminated gas.	Check the gas source for low pressure and leaks. Change to a different gas source or change oxygen removal filter.
Outside diameter discoloration.	Insufficient OD shield gas flow.	Increase flow rate and prepurge time.
	Impurities in the gas supply.	Check gas lines for leaks. Change to a different gas source or change oxygen removal filter.
	Wrong type of gas used.	Change to correct type of gas.
	Contamination on work pieces.	Clean the work pieces before welding.
	Contaminants in the weld head and gas lines.	Increase prepurge time. Check the gas source for low pressure.
	OD shield gas line disconnected from the M200 power supply.	Reconnect gas line.

Table 51—Welding Process

Symptom	Cause	Remedy
Inside diameter discoloration.	Insufficient ID purge gas.	Increase ID purge gas flow rate and prepurge time.
	Contaminants in the ID purge line.	Increase prepurge time. Check the gas source for low pressure.
	Migration of oxygen from the ID purge gas exit port of the work pieces to the weld joint.	Reduce exit port size with a purge restricter. See <i>Note</i> .
	Wrong type of gas used.	Change to correct type of gas.
	Contamination on work pieces.	Clean the work pieces before welding.
	Nicks / cuts in the ID purge gas line.	Replace gas line.
Hole in the weld bead.	Incorrect arc gap.	Reset the arc gap with the arc gap gauge.
	Excessive ID purge gas back pressure or surge.	Remove any obstruction of the ID purge gas flow or reduce the pressure.
	Improper tube preparation.	Inspect and reface tubing.
	Incorrect weld parameter setting (High Amps).	Check and adjust the weld parameter settings.
	Loss of OD shield gas flow.	Check the gas source for low pressure and leaks. Change to a different gas source or change oxygen removal filter.
OD concave weld puddle.	Excessive heat input.	Compare the material, wall thickness and outside diameter size of the components being welded to the weld procedure guideline being used. Verify settings match the guideline and adjust if necessary.
	Insufficient ID purge gas pressure.	Compare flow meter settings to the weld procedure guideline being used. Adjust if necessary.
Electrode touches the work.	Incorrect arc gap.	Reset the arc gap with the arc gap gauge.
	Insufficient arc gap for the material or the heat input.	Increase the arc gap by 0.005 in. (0.13 mm) above weld head user manual settings.
	Work pieces are out of round.	Increase the arc gap or replace the work piece.

Note: The purge restricter must be of adequate size to prevent excessive inside diameter back pressure.

Table 51—Welding Process

Symptom	Cause	Remedy
Incomplete inside diameter penetration.	Insufficient heat input.	Compare the power supply setting to the weld procedure guideline being used. Adjust weld parameters as necessary.
	Incorrect weld procedure guideline.	Compare the material wall thickness and outside diameter size of the work pieces being welded to the weld procedure guideline being used. Adjust weld parameters as necessary.
	Incorrect arc gap.	Reset the arc gap with the arc gap gauge.
	Tip of electrode is worn or ground improperly.	Change the electrode.
	Inconsistent heats of materials or changes in material chemistry.	Verify consistency of material with material supplier. Adjust weld parameters as necessary.
	Weld joint is off-center or misaligned.	Inspect the entire weld joint in the fixture block prior to welding.
After welding, the tubing / fitting assembly is not straight.	The end surfaces of the work pieces being welded are not perpendicular to their center axis.	Prepare the work piece weld ends properly. Refer to the weld head user manual.
	The fixture block side plate screws are not tight.	Tighten screws as needed.
After welding, the fitting / tubing joint is still visible.	The fitting / tubing was not centered properly.	Center fitting / tubing.
	The electrode is bent or was not properly installed.	Inspect the electrode and replace if necessary. Reset the arc gap with the arc gap gauge.

Power Supply Repair

If the M200 power supply needs to be repaired, contact your authorized Swagelok representative. You will need to provide:

- serial and model number of the unit
- complete description of the application
- detailed description of the symptom.

Detailed information will help identify the exact problem and expedite the solution.

Glossary

Active procedure	The procedure loaded for welding. Also called the weld program.
Automatic tube weld (ATW)	A weld using a fitting that has extra material machined integral with the fitting at the weld joint.
Arc	The flow of current between an electrode (cathode) and the work piece (anode).
Arc failure	An action that occurs when the arc fails to sustain itself during the weld.
Arc gap	The distance between the electrode and the work piece.
Arc gap gauge	The gauge used to set the arc gap in the weld head rotor.
Arc start	The period of the welding cycle following prepurge. During arc start (approximately 0.01 second), high voltage is applied between the electrode and work piece, initiating the arc.
Argon	An inert gas used as an OD shield and ID purge gas for gas tungsten arc welding.
Average current	In pulsed-current welding, current levels are set to “pulse” between high amps and low amps during the weld process. Average current is based on high amps current, low amps current, and high amps width. Average current is calculated using the formula: $(High\ Amps \times High\ Amps\ Width) + [Low\ Amps \times (1 - High\ Amps\ Width)] = Average\ Current$
Blast purge	The purge setting used before prepurge and/or after postpurge. This can be used to reduce the overall purge time by increasing the purge gas flow rate prior to prepurge and/or after postpurge.
Butt weld	A weld joint in which two work piece faces are aligned axially.
Centering gauge	Gauge used to center the work pieces in the fixture block.
Concavity	The condition in which the weld profile is below the surface of the work piece.
Dedicated line	An electrical service line used for only one device. A dedicated line isolates the device from interference created by other equipment and allows it to utilize the full current capacity of the line.
Duty cycle	The percentage of time during a 10 minute period that the M200 power supply can operate at a given average current and voltage output setting.
GTAW	Gas tungsten arc welding.

Heat input	The heat conducted into the weld during the weld cycle. Typically expressed in joules or kilojoules.
High amps	The maximum current level generated during the weld process. Also called impulse current.
High amp speed	This is the rotor speed in revolutions per minute during the high (impulse) portion of the weld process.
High amps width	The percentage of time during one cycle that the weld current is at the high amps level.
Inches of water	Fractional unit of pressure measurement. 1 psi = 27.72 inches of water
ID	Inside diameter.
ID purge gas	The gas used within a tube or at the back of a weld joint to remove oxygen and prevent oxidation. Also called backing gas.
Jog	The action to move the rotor clockwise to position the electrode.
Jog back	The action to move the rotor counterclockwise to position the electrode.
Level factor	A percentage of the Level 1 high amps used to calculate the high amps drop in subsequent levels.
Low amps	The minimum current level generated during the weld process. Also called maintenance current.
Low amp speed	This is the rotor speed in revolutions per minute during the low amps portion of the weld process.
Millimeters of water	Metric unit of pressure measurement. 1 bar = 1.02×10^{-4} millimeters of water
Misfire	An action that occurs when the arc fails to start.
Multilevel	A welding technique in which more than one level of current is used during the weld process.
Multipass	A welding technique in which the electrode welds for more than one revolution during the combined levels in the weld procedure. Often used in fusion welding of small diameter parts.
Normal purge	The purge setting used during the weld process. Purge setting includes flow rate and time.
OD	Outside diameter.
OD shield gas	The gas used to shield the electrode and work pieces during the welding process and to cool the weld head.
Orbital welding	A welding technique in which the arc rotates around the weld joint circumference.

Oxidation	A discoloration or tint that occurs in the weld area that is caused by the presence of oxygen. It can vary in color and intensity based on the weld temperature and the amount of oxygen present. Oxidation increases the chances of weld joint corrosion.
Penetration	The depth of the weld at the weld joint. A full-penetration weld completely penetrates the weld joint from the outside diameter to the inside diameter.
Postpurge	The amount of time the OD shield gas is applied after welding to cool the work piece and electrode.
Power supply	The device that produces the electrical power for the welding process. The M200 power supply is a constant-current power supply.
Prepurge	The amount of time the OD shield gas is applied before the arc start.
Pulse rate	The rate at which the output current level is changed between the high amps and low amps settings. The rate is expressed as pulses per second.
Pulse weld	A weld current that varies between a high level and a low level at a specific rate. This technique helps to reduce the heat input to the weld.
Purge gas	The gas (OD shield and ID purge) used at the weld joint or within a tube to prevent oxidation.
Ramp	A time entered into a weld level that allows a gradual amperage change from the previous level or Rotor Delay current.
Rotor	The device that holds the electrode and rotates around the weld joint during orbital welding.
Rotor delay current	The current used to establish a weld puddle at the start of a weld before the rotor moves, normally the average current the the first level of a weld procedure.
Rotor delay time	A time delay that is programmed into the weld procedure after arc start to allow the weld to penetrate the material.
Rotor speed	The rate of rotor travel around the work piece, measured in revolutions per minute. Rotor speed is different for different weld heads. See the weld head user's manual for technical data.
Single level	A welding technique in which a single average value of current is used during the weld process.
Single pass	A welding technique in which the rotor moves one revolution during the weld process.
Socket weld	A basic lap-type weld joint.

Step program	A type of weld procedure in which the rotor speed is different between the high amps pulse time and the low amps pulse time. The rotor speed may vary from zero to the weld head's maximum revolutions per minute.
Tack	A nonpenetrating weld used to hold the joint alignment and joint gap during welding. Usually spaced at three or four places around the tube diameter.
Travel speed	The linear speed of the electrode as it passes over the weld joint, usually expressed in inches per minute or millimeters per second. Also can be expressed in revolutions per minute.
Tungsten	The material used to make the electrode.
Weld coupon	A sample weld made for evaluation purposes. The weld is used for both visual and physical testing.
Weld log	Records and saves a description of each weld procedure, including inputs and outputs and performance confirmation.
Weld pool	The molten metal that actually forms the weld. Also called weld puddle.
Weld procedure	A custom set of weld parameters used for a particular welding job.
Weld time	The portion of the weld process in which the current is at the level needed to fully penetrate the weld joint.

SWAGELOK® EMBEDDED SYSTEM END USER LICENSE AGREEMENT

GENERAL

The Swagelok® Welding System M200 Power Supply ("Product") is being provided to Buyer/Customer/User ("USER") with embedded firmware and software ("Embedded System"). USER agrees that the terms and conditions identified in this document ("Agreement") govern the USER's purchase or use of the Embedded System. No modification to any of the terms and conditions of this document shall be binding upon Swagelok Company and its subsidiaries ("Swagelok") or its independent authorized distributors unless agreed to in writing and signed by Swagelok.

TRADEMARK AND TRADE NAMES

Nothing in this Agreement or with the sale of the Product to USER shall be deemed to give any rights in connection with any trademarks, service marks, or trade names of Swagelok or any third-party product subject to these terms and conditions. Swagelok is a registered trademark of the Swagelok Company.

SOFTWARE OWNERSHIP AND USE

The Embedded System shall be and remain the property of Swagelok or third parties which have granted Swagelok the right to license certain software or its use with the Embedded System, and USER shall have no rights or interests therein except as set forth in this Agreement. USER is granted a non-exclusive, non-transferable, worldwide perpetual right to use the Embedded System received with the Product solely in support of and for use with the Product. USER shall not: (a) install or use on the Embedded System either support software or additional software that provides functions in addition to the embedded application unless that support software or additional software was provided by Swagelok; and (b) access and use desktop functions other than through or in support of the Embedded System. USER may not modify, reverse engineer, decompile, create derivative works, or attempt to derive the composition or underlying information, structure, or ideas of the Embedded System technology. The software is not fault-tolerant and is not designed, manufactured or intended for any use requiring fail-safe performance in which the failure of the licensed software could lead to death, serious injury, severe physical or environmental damage.

SOFTWARE MODIFICATION, RECOVERY, AND UPDATES

Only Swagelok provided recovery or update software may be used on the Embedded System. USER agrees that any license terms provided with update or recovery software along with this License Agreement shall govern USER's use of the software. USER may use one copy of the update or recovery image for all USER purchased Product. USER must keep the update or recovery software and shall not provide, market, or otherwise distribute the updated recovery software which is a separate item from the Embedded System. USER shall either destroy or return to Swagelok any superseded update or recovery software provided to USER on external media.

WARRANTY

SWAGELOK HARDWARE: The standard Swagelok Limited Lifetime Warranty, incorporated herein by reference, applies to the Product hardware.

SOFTWARE AND FIRMWARE: Unless otherwise provided in a separate Swagelok or third-party license agreement, Swagelok warrants for a period of 1 year from the date of shipment that the media on which the Swagelok developed software or firmware is furnished shall be free from defects in material and workmanship and shall conform to the published or other written specifications issued by Swagelok when used with the Product. Swagelok makes no representation or warranty, expressed or implied, that the operation of the software or firmware will be uninterrupted or error free, or that the functions contained in the

software or firmware will meet or satisfy the USER's intended use or requirements.

Satisfaction of this warranty, consistent with other provisions herein, will be limited to the replacement, or repair, or modification of, or issuance of a credit for the Product involved, at Swagelok's option. This warranty shall not apply for (a) any alleged defect caused by misuse; neglect; improper installation, operation, maintenance, repair; alteration or modification; accident; or unusual deterioration or degradation of the software, firmware or parts thereof due to physical environment or due to electrical or electromagnetic noise environment; or (b) any use of the software on a program platform or application/assembly other than that originally supplied or specified with the Product. THIS WARRANTY IS IN LIEU OF ALL OTHER WARRANTIES WHETHER EXPRESS, IMPLIED, OR STATUTORY INCLUDING THE IMPLIED WARRANTIES OF MERCHANTABILITY OR FITNESS FOR A PARTICULAR PURPOSE.

LIMIT OF LIABILITY

In the event that USER should be enjoined in any suit or proceeding arising from a claim for infringement of intellectual property rights from using the Product, except any suit or proceeding based upon a design or modification incorporated in such Product at request of USER, Swagelok, at its option, shall promptly either (a) secure termination of the injunction and procure for USER the right to use such Product without any obligation or liability, or (b) replace such Product with non-infringing materials or modify same to become non-infringing, or (c) remove said Product at Swagelok' expense and refund the purchase price of the infringing Product to USER. THIS SHALL BE USER'S EXCLUSIVE REMEDY AGAINST SWAGELOK WITH RESPECT TO PATENT, COPYRIGHT, OR MASK WORK REGISTRATION INFRINGEMENT. The sale of Product does not convey or transfer copyright under any proprietary or patent rights of any manufacturer.

IN NO EVENT, REGARDLESS OF CAUSE SHALL SWAGELOK OR ITS AUTHORIZED DISTRIBUTORS ASSUME RESPONSIBILITY OR BE LIABLE FOR (a) PENALTIES OR PENALTY CLAUSES OF ANY DESCRIPTION, (b) TO THE EXTENT PERMITTED BY LAW, INDEMNIFICATION OF USER OR OTHERS FOR COSTS, DAMAGES, OR EXPENSES EACH ARISING OUT OF OR RELATED TO THE PRODUCT OR SERVICES OF THIS ORDER, (c) CERTIFICATION, UNLESS OTHERWISE SPECIFICALLY PROVIDED HERE WITH, OR (d) INDIRECT OR CONSEQUENTIAL DAMAGES UNDER ANY CIRCUMSTANCE, INCLUDING ANY LOST PROFITS, BUSINESS INTERRUPTION, OR OTHER DAMAGES. IN NO EVENT SHALL SWAGELOK LIABILITY EXCEED THE PURCHASE PRICE FOR THE PRODUCT REGARDLESS OF THE FORM OF ACTION, WHETHER IN CONTRACT OR TORT, INCLUDING NEGLIGENCE OR OTHER LEGAL BASIS.

EXPORT COMPLIANCE

USER shall comply with all applicable export laws at the point that the Product, its Embedded System or components thereof are transferred to USER's possession. USER agrees to indemnify and hold harmless Swagelok for any losses sustained as a result of USER's failure to comply with U.S. or foreign import and export laws, rules or regulations in connection with the Product, Embedded System or components thereof.

MISCELLANEOUS

The original English language version of this Agreement shall govern. Any translation is provided as a courtesy only. The United Nations Convention for the International Sale of Goods is specifically excluded.

Warranty Information

Swagelok products are backed by The Swagelok Limited Lifetime Warranty. For a copy, visit swagelok.com or contact your authorized Swagelok representative.

Swagelok—™ Swagelok Company
Microsoft, Excel, Access—™ Microsoft Corporation
© 2007–2021 Swagelok Company
July 2021, RevE
MS-13-212