

Hand Tube Bender Manual



Swagelok®

Contents

Introduction	4
Tubing Data	4
Tubing Installation	6
Product Information	7
Vise Clamp Block	8
Bend Layout	9
Using the Bender	12
Making Bends	15
Reverse Bends	18
Springback	19
Determining Changes in Plane and Direction	20
Adjustment (Gain) Calculations	21
Troubleshooting	24
Replacement Parts	26

Introduction

Swagelok® hand tube benders provide consistent, high-quality bends in tubing made from most materials used with Swagelok tube fittings.

Read this manual before using the hand tube bender.

Tubing Data

- The Swagelok hand tube bender bends 1/4, 5/16, 3/8, and 1/2 in., and 6, 8, 10, and 12 mm outside diameter tubing in a variety of wall thicknesses.
- Tubing should be free of scratches and suitable for bending.

Suggested Tubing Ordering Information

Fractional Tubing

High-quality, soft-annealed, seamless carbon steel hydraulic tubing ASTM A179 or equivalent. Hardness 72 HRB (130 HV) or less.

Fully annealed, high-quality (Type 304, 316 etc.) (seamless or welded and drawn) stainless steel hydraulic tubing ASTM A269 or A213, or equivalent. Hardness 90 HRB (200 HV or less).

Tube OD	Approx Bend Radius	Carbon Steel Wall Thickness Min/Max	Stainless Steel Wall Thickness Min/Max
Dimensions, in.			
1/4	9/16	0.028/0.065	
	3/4	0.028/0.065	
5/16	15/16	0.035/0.065	
3/8	15/16	0.035/0.065	0.035/0.083
1/2	1 1/2	0.035/0.083	

Metric Tubing

High-quality, soft-annealed, carbon steel hydraulic tubing DIN2391 or equivalent. Hardness 130 HV (72 HRB) or less.

Fully annealed, high-quality (Type 304, 316 etc.) stainless steel tubing EN ISO 1127 or equivalent. Hardness 200 HV (90 HRB) or less.

Tube OD	Approx Bend Radius	Carbon Steel Wall Thickness Min/Max	Stainless Steel Wall Thickness Min/Max
Dimensions, mm			
6	15	0.8/1.5	
8	24	1.0/1.5	
10	24	1.0/1.5	1.0/2.0
12	38	1.0/2.2	1.0/2.0

Tubing Installation

Properly selected tubing, combined with quality Swagelok tube fittings, can provide leak-tight systems.

When installing fittings near tube bends, there must be a sufficient length of straight tubing to allow the tube to be bottomed in the Swagelok tube fitting:

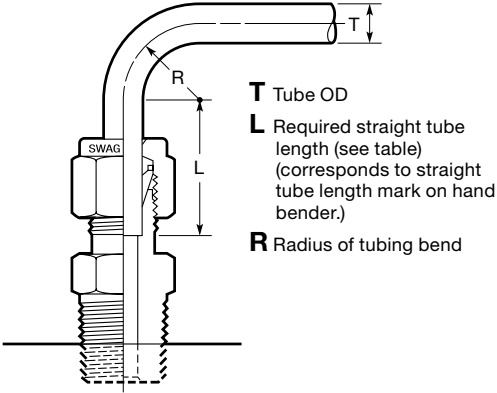

Fractional, in.		
T Tube OD	R Bend Radius	L
1/4	9/16	13/16
	3/4	
5/16	15/16	7/8
3/8	15/16	15/16
1/2	1 1/2	1 3/16

Metric, mm		
T Tube OD	R Bend Radius	L
6	15	21
8	24	23
10	24	25
12	38	31

Product Information

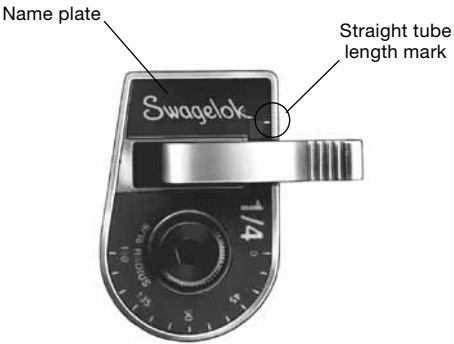
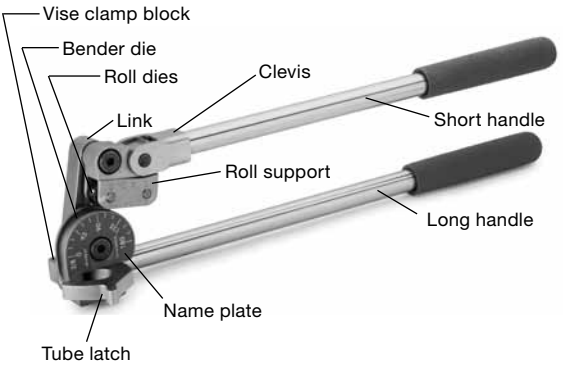

Vise Clamp Block

The Swagelok hand tube bender features a vise clamp block which allows the bender to be clamped in a vise. This feature is helpful when bending tube of a hard material or heavy wall thickness, or long pieces of tubing that need to be supported.

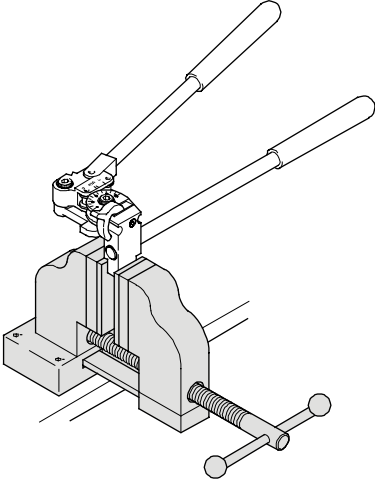

Bend Layout

This bender can be used to form single, offset, and other bends. This section contains information for measuring and marking the tube prior to bending.

Note: Make all marks 360° around the tube.

The Measure-Bend Method

1. Estimate the overall length of tubing required by adding the length of all the sections together.
2. Place a reference mark at the end of the tube from which you are beginning the measurement.
3. Measure from the reference mark and make a bend mark on the tube at a distance equal to the desired bend length. This mark indicates the vertex of the bend.
4. See **Using the Bender**, page 12, to bend the tube.
5. For additional bends, use the vertex of the previous bend as the reference mark, repeat steps 3 and 4 for the next bend. (The vertex is where the center lines of the two legs of the angle intersect.)

An example appears on the next page.

Example of the measure-bend method:

A 90° bend 4 inches from the reference mark followed by a 45° bend with 4 inches between bends.

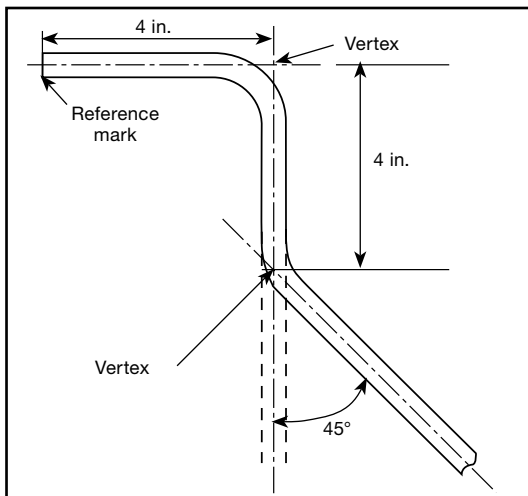

1. Place a **reference mark** at the end of the tube from which you are beginning the measurements.
2. Measure 4 in. from the **reference mark** and make a **bend mark** to indicate the first desired bend length.
3. Bend the tube 90° as described in **Using the Bender**, page 12.
4. Make a second bend mark 4 in. from the **vertex** of the 90° bend, away from the reference mark.
5. Place a **directional mark** over the bend mark to indicate the outside, or heel, of the 45° bend. This will help ensure the bend is made in the intended direction.

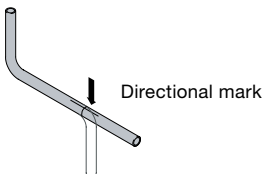

6. Bend the tube 45° as described in **Using the Bender**, page 12.

Offset Bend Formula

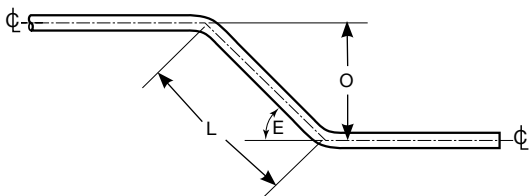

The purpose of an offset bend is to change the center line of the run, typically to avoid an obstruction. To determine the length of offset, select the offset angle (E). Then, multiply the offset dimension (O) by the offset bend allowance (A).

$$L = O \times A$$

Use the offset calculation as the distance between the bend marks described in **Bend Layout**.

Offset Bend Angle (E)	Offset Bend Allowance (A)
22 1/2°	2.613
30°	2.000
45°	1.414
60°	1.154

Example

Offset bend angle (E) 45°
Offset dimension (O) 6.75 in.

$6.75 \times 1.414 = 9.55$ in., or approximately 9 9/16 in.

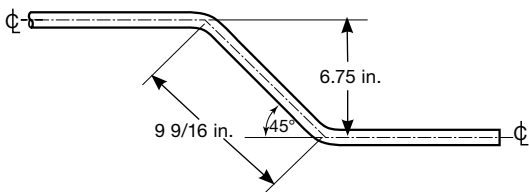

Using the Bender

1. Swing the **short handle** up so it is above the **bender die**.
2. Open the **tube latch**.

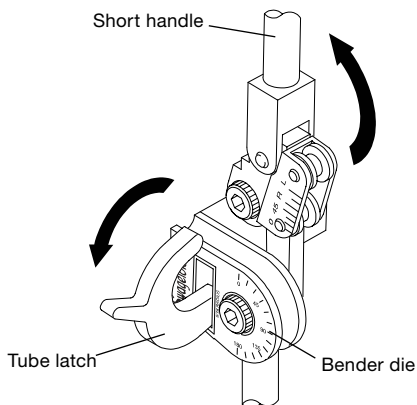

3. Place the tube in the groove of the **bender die** with the **reference mark** to the left of the **tube latch**.
4. Close the **tube latch** over the tube just enough to hold the tube in place. This restricts movement of the tube during initial positioning but still allows for additional alignment.

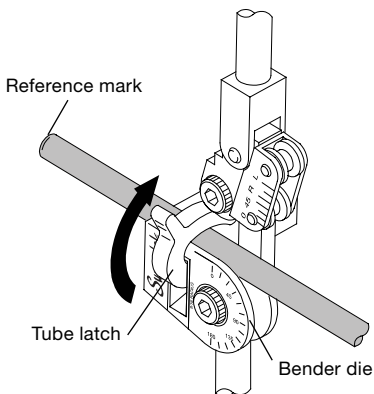

5. Carefully lower the **short handle** until the **roll dies** rest gently on the tube while keeping the **link** straight and parallel to the **long handle**.

Note: Premature bending may occur if the **link** is not straight and parallel to the **long handle**.

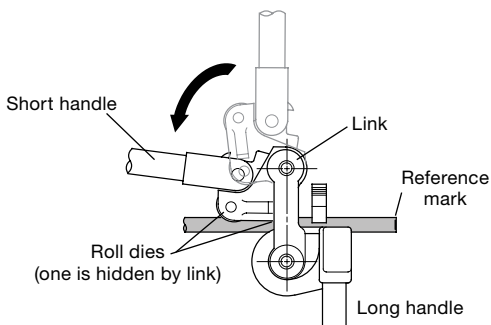

Note: View shown is from the back of the bender.

6. Align the zero on the **roll support** with the zero on the **name plate**.

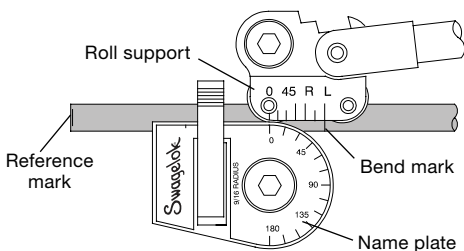

Shown aligned for a 90° bend.

7. Align the bend mark with the mark on the roll support that corresponds to the bend angle.

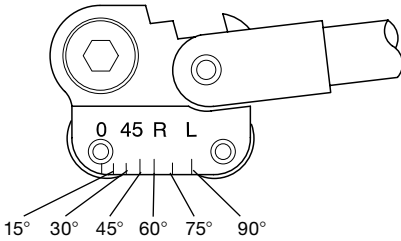

Note: View the marks on the hand tube bender as a 0 to 90° scale when bending other angles.

8. Push the **tube latch** firmly over the tube to secure the tube in the **bender die**.

Note: Excessive pressure on the tube latch may damage soft tubing.

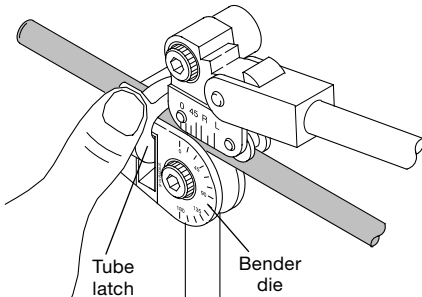

Making Bends

Bends 90° or Less

1. Slowly push the **short handle** down until the 0 on the **roll support** reaches the desired degree mark on the **name plate**.

Note: Be aware of springback, described on page 19.

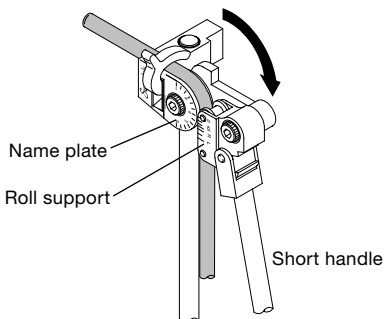

2. After completing the bend, swing the **short handle** up and away from the tube.

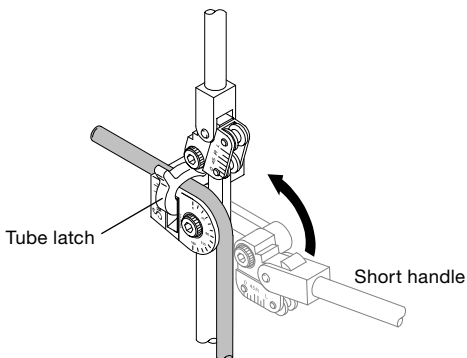

3. Pull the **tube latch** off the tube and remove the tube from the bender groove.

Bends Greater than 90°

The right-angle design of the Swagelok hand tube bender offers maximum leverage when making bends. The bender's unique design lets you continue using right angle leverage for bends greater than 90°.

1. Slowly push the **short handle** down until the 0 on the **roll support** reaches approximately 90° on the **name plate**.

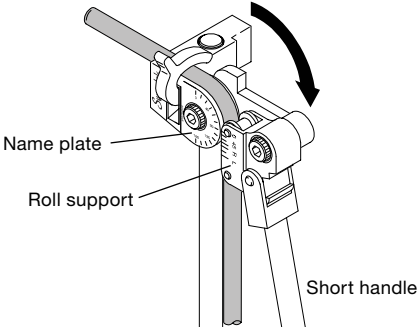

2. Loosen the **short handle** from the **clevis** until the short handle will swing without moving the **roll support**.

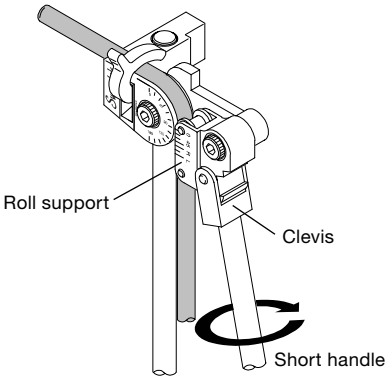

3. Swing the **short handle** up until it is slightly above perpendicular to the **long handle**.
4. Retighten the **short handle**. This will provide continuous right-angle leverage for the rest of the bend.

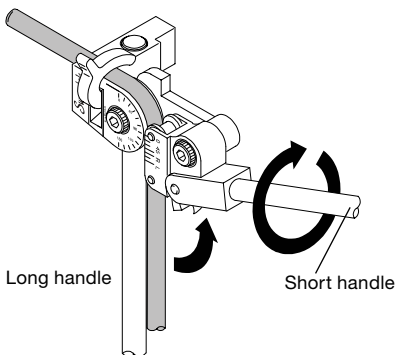

5. Continue the bend until the 0 on the **roll support** reaches the desired degree mark on the **name plate**.

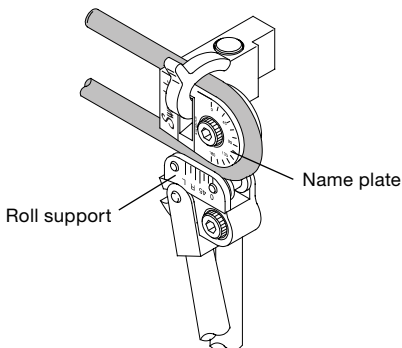

6. After completing the bend, swing the **short handle** away, pausing when the 0 on the **roll support** reaches approximately 90°. Loosen the short handle, move it until parallel with the long handle, then retighten the short handle.
7. Move the short handle up and away from the tube.
8. Pull the tube latch off the tube and remove the tube from the bender groove.

Reverse Bends

The Measure-Bend Method

Sometimes a multiple bend layout will require that a bend be made in reverse. A reverse bend is made with the reference mark to the right of the tube latch.

1. Align the bend mark with the marks on the roll support as follows:
 - 90° bends line up under the R mark
 - For other bend angles, treat the marks between 0 and R as an approximate 0 to 90 scale.

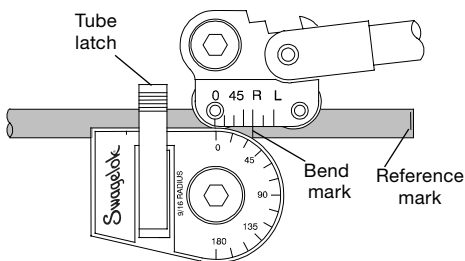

Shown aligned for a 90° reverse bend.

2. Bend the tube as described in **Making Bends**, page 15.

Springback

All tubing will exhibit springback after a bend has been completed. The amount of springback depends on the bend angle, bend radius, tubing material, and wall thickness.

Experience will help you predict the amount of springback. Expect to allow 1 to 3° of compensation.

Note : Verify the bend angle using a template, protractor or against a known angle to ensure the desired bend angle has been achieved.

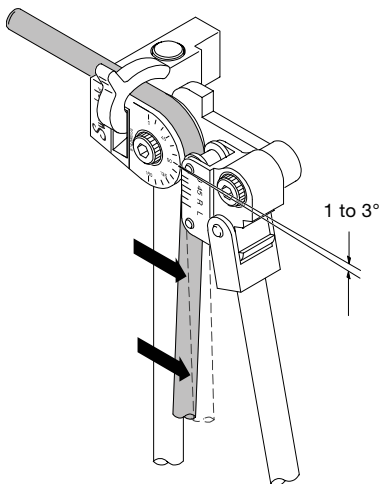

Note: Do not bend all the way to the bend mark when bending softer tubing such as copper or aluminum.

Determining Changes in Plane and Direction

When making multiple bends on a single piece of tube, make sure the bend is made in the correct direction.

For bends in the opposite direction of the previous bend, align the tube with the raised short handle (plane A).

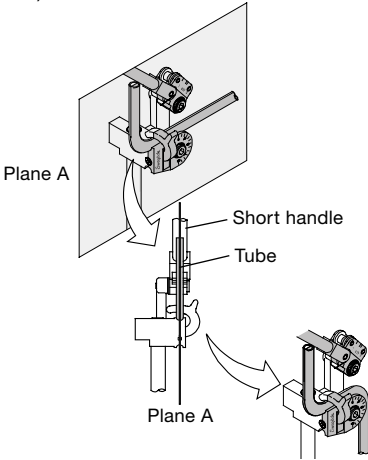

For bends in the same direction as the previous bend, align the tube parallel to the long handle (plane B).

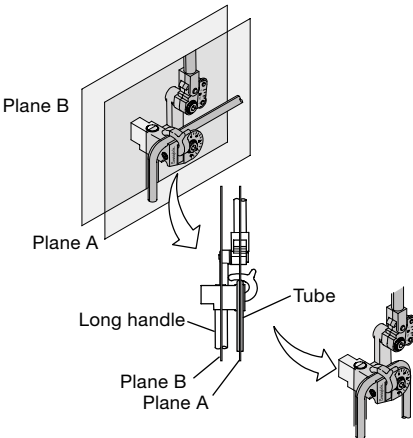

Adjustment (Gain) Calculations

When determining tube bend location, adjustment (gain) factors can be considered as an alternate way to achieve the desired layout.

Adjustment is the difference in the length of tubing used in a radiused bend compared to the length of tubing required in a sharp bend, when measured from the beginning to the end of the bend.

Note: The distance around a radiused bend is always less than a sharp bend.

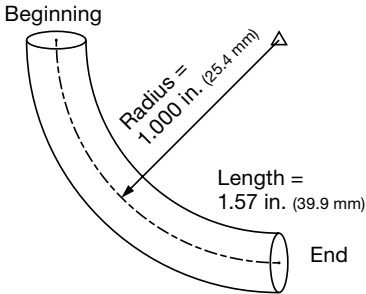

Radiused Bend

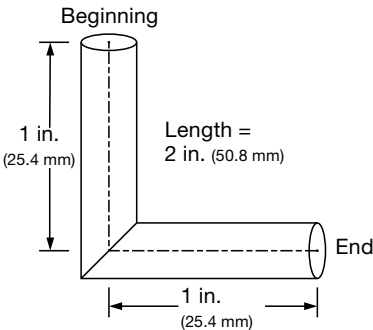

Sharp Bend

Example

1/4 in. tubing using a 1/4 in. bender with a 9/16 in. bend radius.

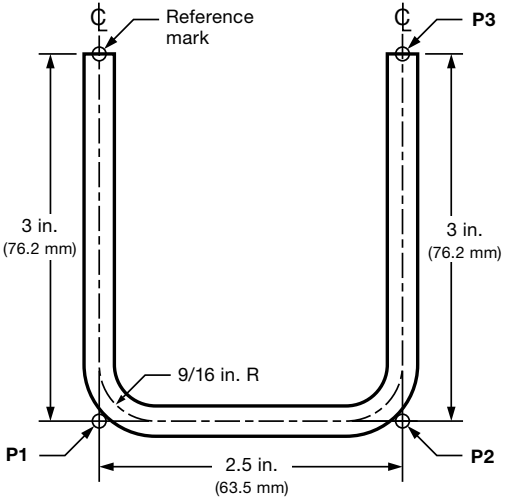

To achieve the desired bend, mark the tubing as follows:

P1 = 3 in.

To determine the location of the bend mark for a subsequent bend, add the *new* section leg length to the *previous* bend mark location, then subtract the adjustment (gain) of the *previous* bend.

P2 = P1 + 2.5 in. - 5/16 in. adjustment = 5 3/16 in.

P3 = P2 + 3 in. - 5/16 in. adjustment = 7 7/8 in.

7 7/8 inches is the total length of tube needed.

90° adjustment = 5/16 in.

Bend the tube as described in **Using the Bender**, page 12.

Fractional Adjustment Calculations

Bend Angle	Tube OD, in.				
	1/4	1/4	5/16	3/8	1/2
	Bend Radius, in.				
	9/16	3/4	15/16	15/16	1 1/2
30°	0	0	0	0	1/16
45°	1/16	1/16	1/16	1/16	1/16
50°	1/16	1/16	1/16	1/16	1/8
55°	1/16	1/16	1/8	1/8	1/8
60°	1/8	1/16	1/8	1/8	3/16
65°	1/8	1/8	3/16	1/8	1/4
70°	1/8	1/8	3/16	3/16	5/16
75°	3/16	3/16	1/4	1/4	3/8
80°	3/16	3/16	5/16	5/16	7/16
85°	1/4	1/4	3/8	3/8	9/16
90°	5/16	5/16	7/16	7/16	11/16

Metric Adjustment Calculations

Bend Angle	Tube OD, mm			
	6	8	10	12
	Bend Radius, mm			
	15	24	24	38
30°	1	1	1	1
45°	1	2	2	3
50°	2	2	2	3
55°	2	3	3	4
60°	3	3	4	5
65°	3	4	4	7
70°	4	5	5	8
75°	5	6	7	10
80°	6	8	8	12
85°	7	10	10	15
90°	8	12	12	18

Adjustments on angles of less than 30° are minimal.

Troubleshooting

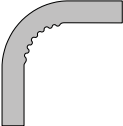
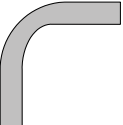
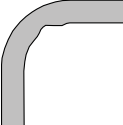
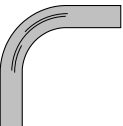
Tube Bending Defect	Cause	Solution
Wrinkled bend 	Undersized bend radius	Increase bend radius
	Tube wall thickness too thin	Increase wall thickness
Flattened bend 	Bender is intended for use with a larger tubing diameter	Use the correct size bender for the tubing being bent
	Tubing is collapsing during bending	Increase wall thickness
	Pressure die is flattening the tubing during the bending operation	Use a bender equipped with rollers instead of a pressure die
Kinked bend 	Bender is intended for use with a larger tubing diameter	Use the correct size bender for the tubing being bent
	Premature bending caused by link not remaining vertical prior to bending	Make sure the link is vertical before placing rollers on tubing
Scored tubing 	Bender is intended for use with a smaller tubing diameter	Use the correct size bender for the tubing being bent
	Damaged bender die	Repair or replace bender/die
	Dirt or foreign matter in bender die/shoe or roller	Clean bender die/shoe or roller
	Frozen roller	Replace damaged roller or bender

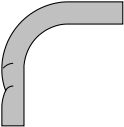
Tube Bending Defect	Cause	Solution
Excessive tubing deformation 	Improper alignment	Make sure that the bender die and bend shoe are aligned
	Excessive pressure on the tube latch (generally visible on softer tubing only)	Reduce latch pressure

Replacement Parts

Hand Tube Bender Components

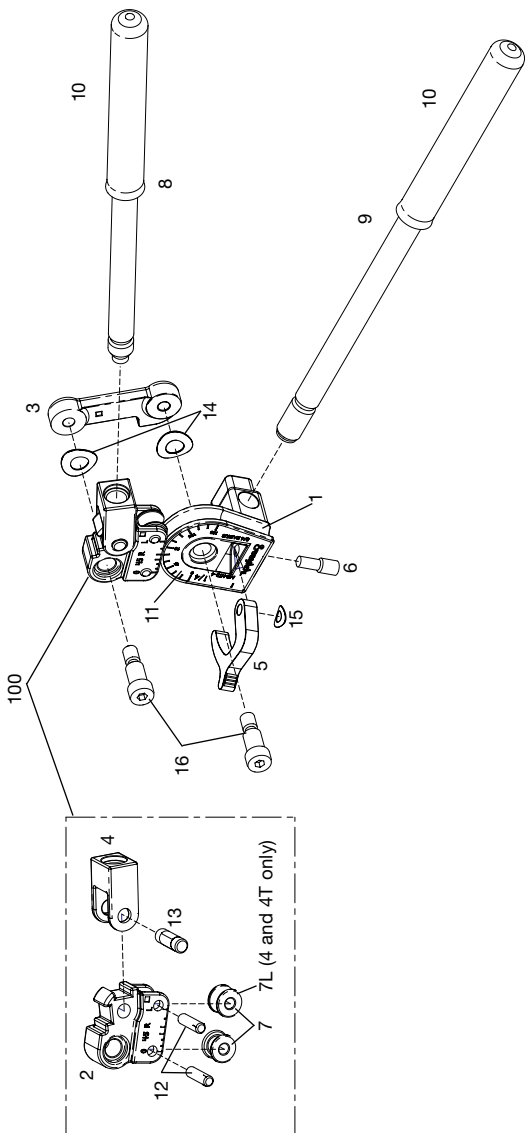

Hand Tube Bender Component Descriptions

Component	Description
1	Bender die
2	Roll support
3	Link
4	Clevis
5	Latch
6	Latch screw
7	Roll die
7L	Lead roll die
8	Short handle subassembly
9	Long handle subassembly
10	Handle grip
11	Name plate
12	Lock dowel
13	Clevis pin
14	Spring washer - link
15	Spring washer - latch
16	Shoulder screw
100	Roller subassembly

Repair Kits

Repair kits contain a link, shoulder screws, spring washers, thread locking adhesive, a material safety data sheet, and instructions.

Bender Ordering Number	Repair Kit Ordering Number
MS-HTB-4	MS-HTBR-4L
MS-HTB-4T	MS-HTBR-4TL
MS-HTB-6M	MS-HTBR-6ML
MS-HTB-5 MS-HTB-8M MS-HTB-6T MS-HTB-10M	MS-HTBR-6TL
MS-HTB-8 MS-HTB-12M	MS-HTBR-8L

Grip Kits

Grip kits contain two handle grips.

Bender Ordering Number	Grip Kit Ordering Number
MS-HTB-4 MS-HTB-4T MS-HTB-6M	MS-HTB-GK4
MS-HTB-5 MS-HTB-8M MS-HTB-6T MS-HTB-10M	MS-HTB-GK6
MS-HTB-8 MS-HTB-12M	MS-HTB-GK8

Roller Subassemblies

A roller subassembly contains a roll support, clevis, roll dies, clevis pin, and lock dowels assembled together at the factory.

Bender Ordering Number	Roller Subassembly Ordering Number
MS-HTB-4	MS-HTB-4-100
MS-HTB-4T	MS-HTB-4T-100
MS-HTB-6M	MS-HTB-6M-100
MS-HTB-5	MS-HTB-5-100
MS-HTB-8M	MS-HTB-8M-100
MS-HTB-6T	MS-HTB-6T-100
MS-HTB-10M	MS-HTB-10M-100
MS-HTB-8	MS-HTB-8-100
MS-HTB-12M	MS-HTB-12M-100

Hand Tube Bender Components

These components may be ordered individually.

Component	Bender Ordering Number	Component Ordering Number
Short handle sub-assembly	MS-HTB-4 MS-HTB-4T MS-HTB-6M	MS-HTB-4-008SA
	MS-HTB-5 MS-HTB-8M MS-HTB-6T MS-HTB-10M	MS-HTB-6-008SA
	MS-HTB-8 MS-HTB-12M	MS-HTB-8-008SA
Long handle sub-assembly	MS-HTB-4 MS-HTB-4T MS-HTB-6M	MS-HTB-4-009SA
	MS-HTB-5 MS-HTB-8M MS-HTB-6T MS-HTB-10M	MS-HTB-6-009SA
	MS-HTB-8 MS-HTB-12M	MS-HTB-8-009SA
Name plate	MS-HTB-4	MS-HTB-4-011
	MS-HTB-4T	MS-HTB-4T-011
	MS-HTB-6M	MS-HTB-6M-011
	MS-HTB-5	MS-HTB-5-011
	MS-HTB-8M	MS-HTB-8M-011
	MS-HTB-6T	MS-HTB-6T-011
	MS-HTB-10M	MS-HTB-10M-011
	MS-HTB-8	MS-HTB-8-011S
MS-HTB-12M	MS-HTB-12M-011S	

Component	Bender Ordering Number	Component Ordering Number
Spring washer - link	MS-HTB-4	927-002
	MS-HTB-4T	
	MS-HTB-6M	
	MS-HTB-5	927-004
	MS-HTB-8M	
	MS-HTB-6T	
	MS-HTB-10M	
	MS-HTB-8	927-006
	MS-HTB-12M	
Shoulder screw	MS-HTB-4	763-006
	MS-HTB-4T	
	MS-HTB-6M	
	MS-HTB-5	763-007 ^① 763-007L ^②
	MS-HTB-8M	
	MS-HTB-6T	
	MS-HTB-10M	
	MS-HTB-8	763-008
	MS-HTB-12M	

① Ordering number for shoulder screw to be used with a link not containing a counterbore.

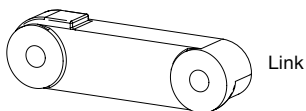

② Ordering number for shoulder screw to be used with a link containing a counterbore.

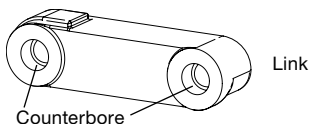

Swagelok—TM Swagelok Company
© 2009–2012 Swagelok Company
Printed in U.S.A., AGS
February 2012, R3
MS-13-43