

Remote-Mount Manifold

Two Valve

Features

- Non-rotating hardened needle design for leak-tight shutoff and long service life
- Angled vent valve for panel mounting
- Working pressures up to 6000 psig (413 bar)
- All stainless steel construction with PTFE packing and seals
- Color-coded valve label rings for easy valve identification
- Available graphite packing and seals for high-temperature service



Instrument Side

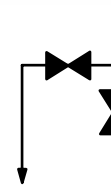

Process Side

Stainless steel handle with square drive stem and locknut to ensure positive actuation

Stem threads are cold rolled for high strength and smooth operation

Two-piece knuckle joint provides non-rotating needle feature. Joint is located above the packing, protected from system media

Non-rotating, hardened needle for positive shutoff

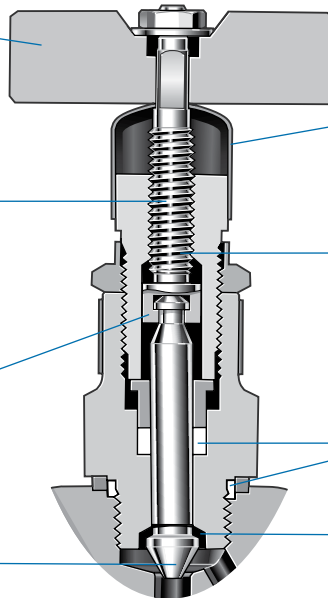

Shroud protects stem threads against ingress of dirt and dust

Stem threads above packing protected from system media

Choice of packing and bonnet seal materials

Safety back seating needle seals in fully open position

Pressure-Temperature Ratings

Valve Packing	Pressure psig (bar)	Temperature °F (°C)
PTFE	6000 (413)	200 (93)
	4000 (275)	400 (204)
Graphite	6000 (413)	200 (93)
	3000 (206)	850 (454)

Materials of Construction

Component	Material / ASTM Specification	
<i>Body</i>	316/316L SS / A479	
<i>Bonnets</i>		
<i>Needles</i>	S17400 SS / A564 Condition H1150D	
<i>Packings</i>	PTFE	
<i>Bonnet seals</i>		
Bonnet seal rings		
Gland nuts		
Shrouds		
Glands		
Handles		316 SS
Handle locknuts		
Handle washers		
Stems		
Locking pins		
Gland locknuts		
Lubricant		

Wetted components listed in *italics*.

Dimensions

Dimensions, in inches (millimeters), are for reference only and are subject to change.

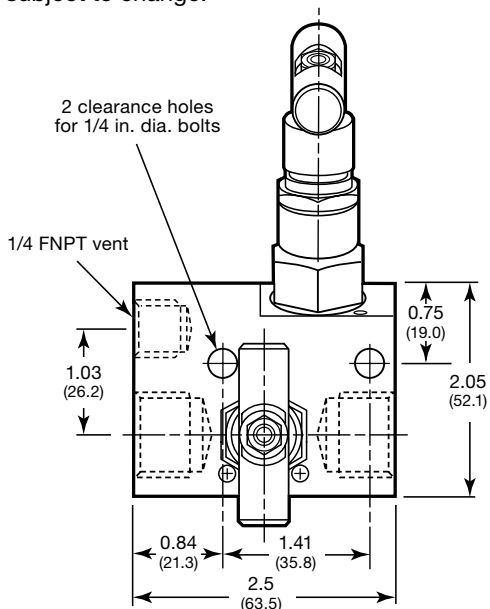

Testing

Every remote-mount, 2-valve manifold is factory tested hydrostatically. A shell test is performed at 1.5 times maximum rated working pressure and a seat test is performed at 1.1 times maximum rated working pressure, in accordance with BS EN 12266-1 (formerly BS 6755 part 1).

Ordering Information

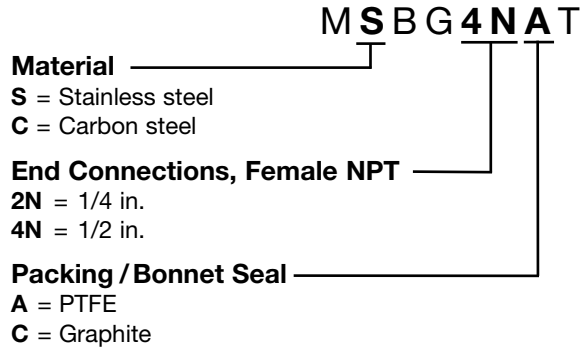

- ⚠ Packing adjustment may be required during the service life of the valve to prevent leakage.
- ⚠ Valves that have not been cycled for a period of time may have a higher initial actuation torque.

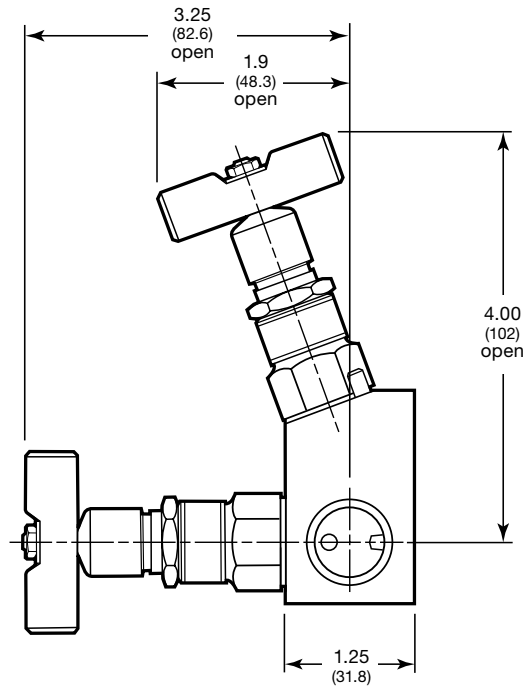

Safe Product Selection

When selecting a product, the total system design must be considered to ensure safe, trouble-free performance. Function, material compatibility, adequate ratings, proper installation, operation, and maintenance are the responsibilities of the system designer and user.

Caution: Do not mix or interchange parts with those of other manufacturers.