

# Instrument Isolation Valves

Block and Bleed and  
Double Block and Bleed Valves

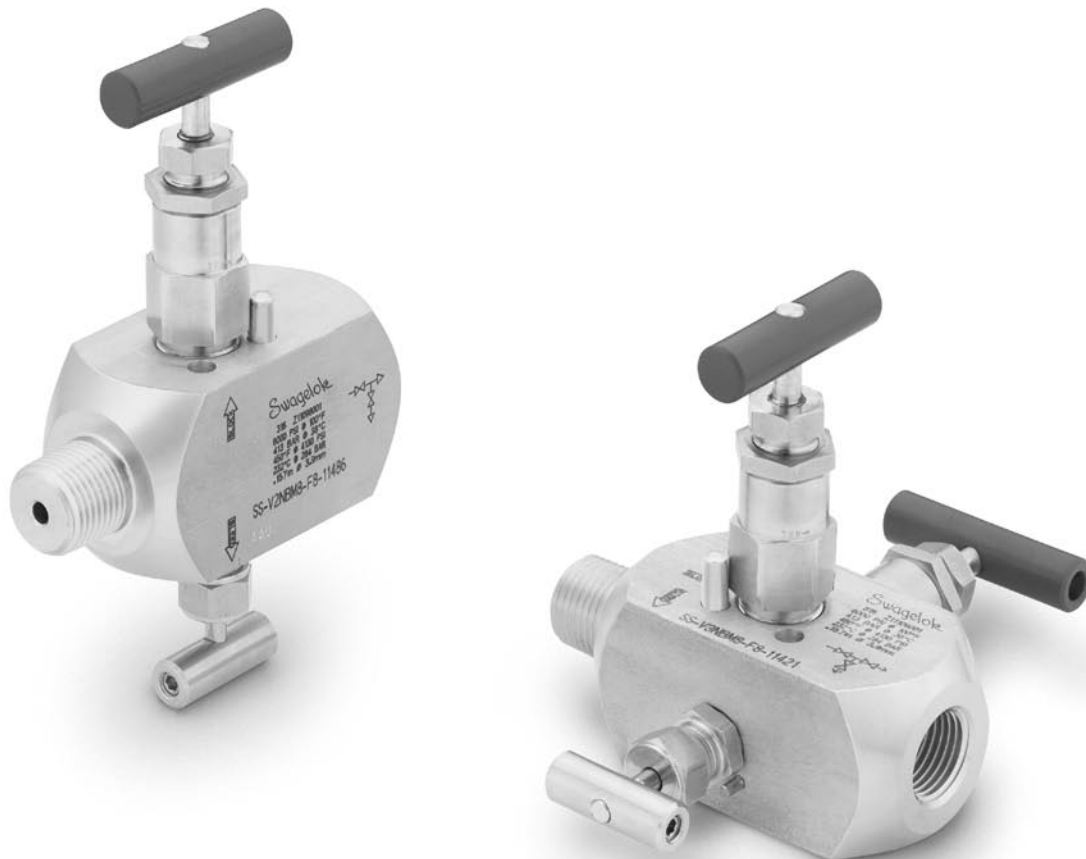

## V Series

- Working pressures up to 6000 psig (413 bar)
- Temperatures up to 450°F (232°C) with PTFE packing;  
up to 1200°F (648°C) with Grafoil® packing
- 100 % factory tested

## Features

- Compact instrument isolation valves with integral block and bleed functions offer advantages over configurations with multiple valves and fittings:
  - cost savings from fewer components required
  - minimal space needed for installation and operation
  - reduced potential for leakage.
- 316 stainless steel stop pin design is vibration tested to MIL-STD 167-1, Sections 5.1.2.4.2 through 5.1.2.4.6.
- Metal-to-metal body-to-bonnet seal eliminates the need for O-ring or elastomer seals.
- PTFE (standard) and Grafoil (optional) stem packing are externally adjustable in the open position.

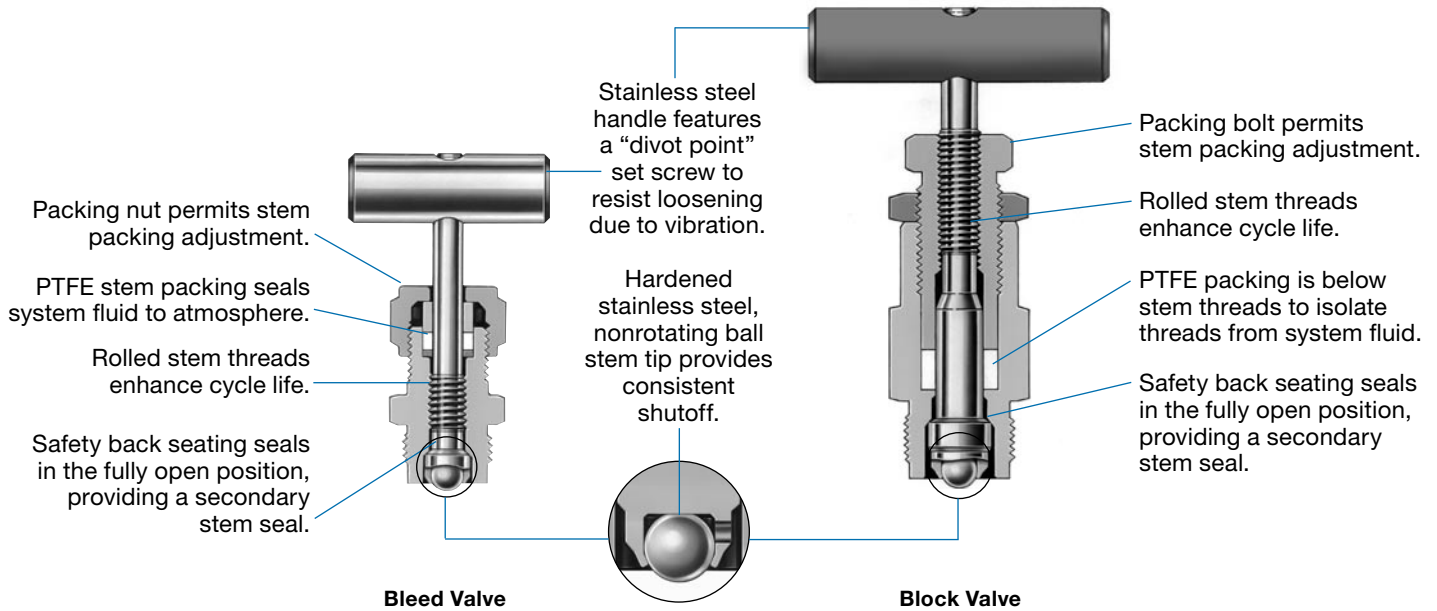

## Technical Data

<b>Orifice Size</b>	Bleed valves—0.125 in. (3.2 mm)
	Block valves—0.156 in. (4.0 mm)
<b>Weight</b>	Block and bleed valves— 2.75 to 3.00 lb (1.25 to 1.36 kg)
	Double block and bleed valves— 3.10 to 3.35 lb (1.41 to 1.52 kg)

## Testing

Every Swagelok® instrument isolation valve is factory tested with nitrogen at 1000 psig (69 bar). Seats have a maximum allowable leak rate of 0.1 std cm<sup>3</sup>/min.

Shell testing is performed with a liquid leak detector to a requirement of no detectable leakage.

## Cleaning and Packaging

Every Swagelok instrument isolation valve is cleaned and packaged in accordance with Swagelok *Standard Cleaning and Packaging (SC-10)*, MS-06-62.

## Pressure-Temperature Ratings

Ratings based on optional Grafoil stem packing.  
Ratings limited to 450°F (232°C) with standard PTFE packing.

ASME Class	2500
Material Group	2.2
Material Name	316 SS
Temperature °F (°C)	Working Pressure psig (bar)
-65 (-53) to 100 (37)	6000 (413)
200 (93)	5160 (355)
250 (121)	4910 (338)
300 (148)	4660 (321)
350 (176)	4470 (307)
400 (204)	4280 (294)
450 (232)	4130 (284)
500 (260)	3980 (274)
550 (260)	3870 (266)
600 (315)	3760 (259)
650 (343)	3700 (254)
700 (371)	3600 (248)
750 (398)	3520 (242)
800 (426)	3460 (238)
850 (454)	3380 (232)
900 (482)	3280 (225)
950 (510)	3220 (221)
1000 (537)	3030 (208)
1050 (565)	3000 (206)
1100 (593)	2685 (184)
1150 (621)	2285 (157)
1200 (648)	1715 (118)

## Materials of Construction

Materials for pressure-containing wetted parts are in compliance with ASME B31.1.

Component	Material Grade/ ASTM Specification
1 Handles <sup>①</sup>	316 SS/A479
2 Set screws	
3 Packing bolts	
4 Packing nuts	
5 Upper glands	
6 Jam nuts	316 SS/A276
7 Packings	PTFE/D1710
8 Lower glands	316 SS/A240 or A167
9 Bonnets	316 SS/A479
10a Stems	316 SS/A276
10b Ball tips	316 SS/A479
11 Bodies	
12 Stop pins	316 SS/A479
Lubricants	Fluorinated base with PTFE and tungsten disulfide
	Hydrocarbon-based

Wetted components listed in *italics*.

① Block valve handles are blue enamel coated.

## Block and Bleed Valves

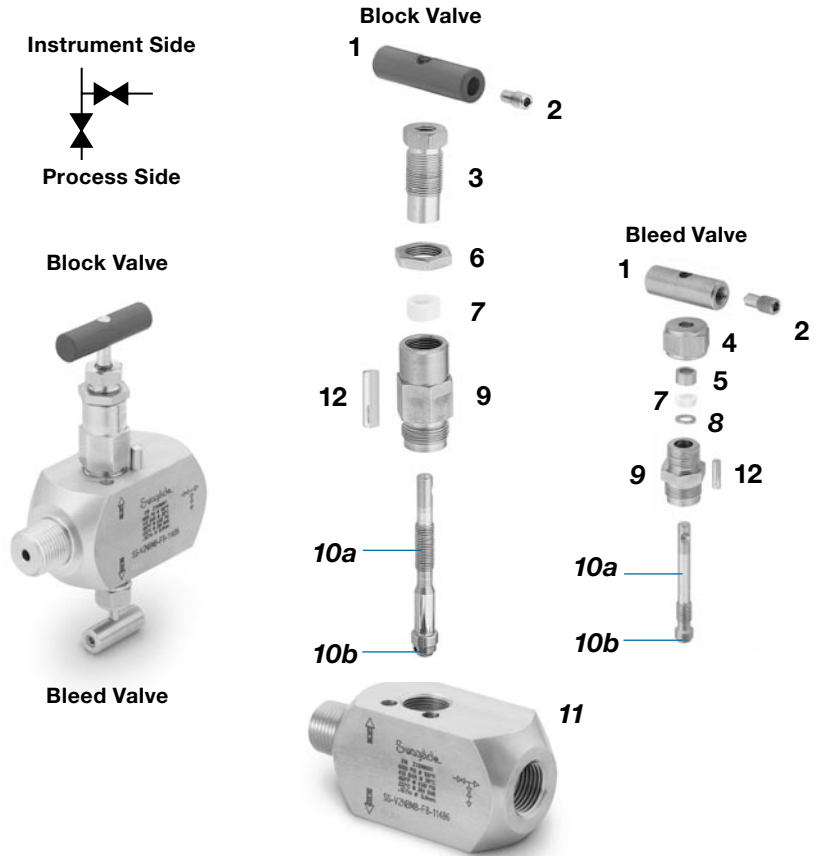

## Double Block and Bleed Valves

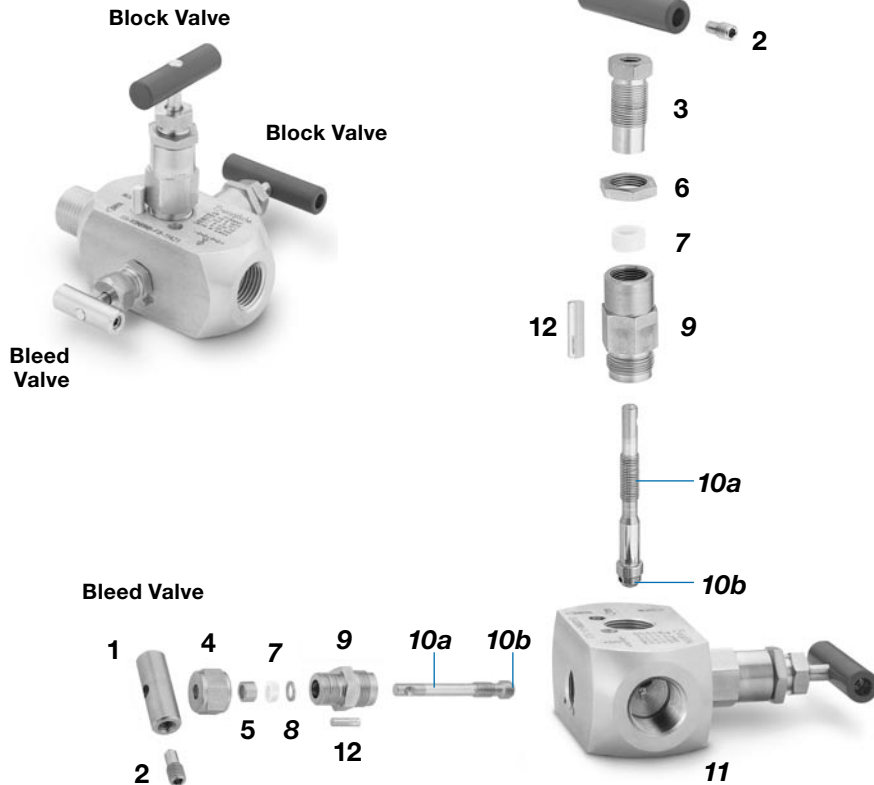
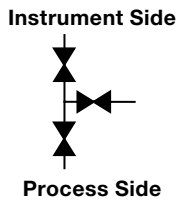

## Ordering Information and Dimensions

Dimensions, in inches (millimeters), are for reference only and are subject to change.

Select an ordering number. To order an instrument isolation valve with optional Grafoil packing, insert **-G** into the ordering number.

Example: SS-V2NBM8-F8-**G**-11486

### Block and Bleed Valves

Inlet End Connection	Ordering Number
1/2 in. male NPT	SS-V2NBM8-F8-11486
3/4 in. male NPT	SS-V2NBM12-F8-11486

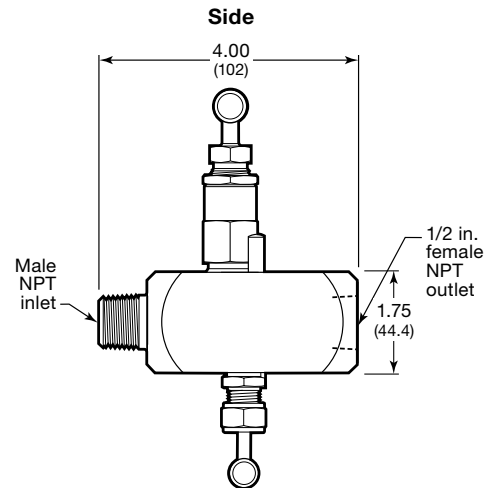
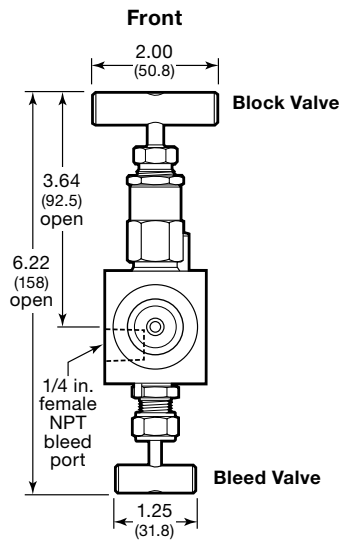
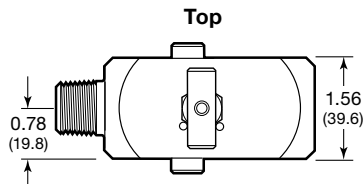

### Double Block and Bleed Valves

Inlet End Connection	Ordering Number
1/2 in. male NPT	SS-V3NBM8-F8-11421
3/4 in. male NPT	SS-V3NBM12-F8-11421

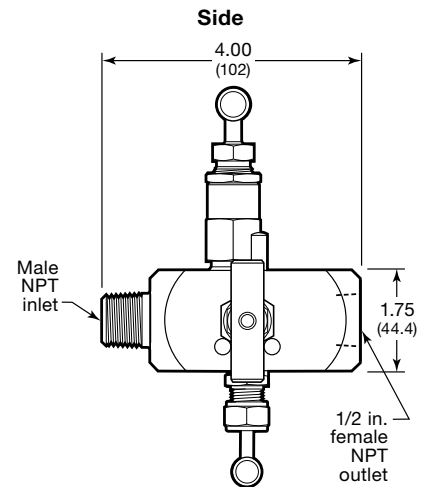
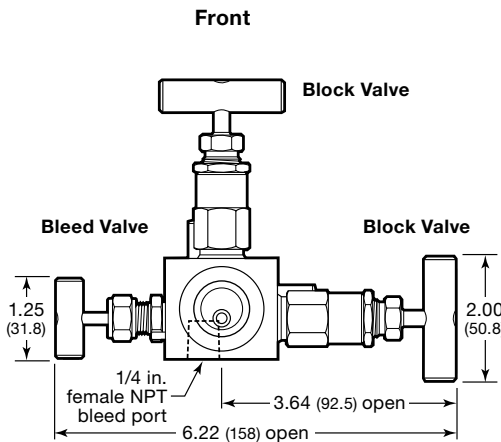
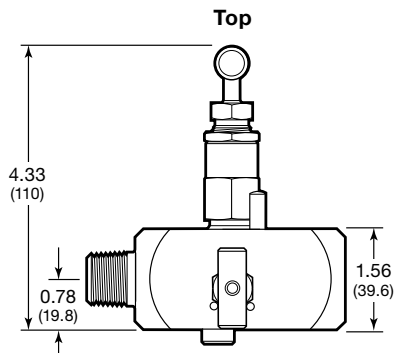

**⚠ Packing adjustments may be required during the service life of the valve.**

**⚠ Valves that have not been cycled for a period of time may have a higher initial actuation torque.**

#### Safe Product Selection

When selecting a product, the total system design must be considered to ensure safe, trouble-free performance. Function, material compatibility, adequate ratings, proper installation, operation, and maintenance are the responsibilities of the system designer and user.

**Caution: Do not mix or interchange parts with those of other manufacturers.**

#### Warranty Information

Swagelok products are backed by The Swagelok Limited Lifetime Warranty. For a copy, visit [swagelok.com](http://swagelok.com) or contact your authorized Swagelok representative.